

## About this Manual

We've added this manual to the Agilent website in an effort to help you support your product. This manual is the best copy we could find; it may be incomplete or contain dated information. If we find a more recent copy in the future, we will add it to the Agilent website.

## Support for Your Product

Agilent no longer sells this product. Our service centers may be able to perform calibration and repair if necessary, but no other support from Agilent is available. You will find any other available product information on the Agilent Test & Measurement website, [www.tm.agilent.com](http://www.tm.agilent.com).

## HP References in this Manual

This manual may contain references to HP or Hewlett-Packard. Please note that Hewlett-Packard's former test and measurement, semiconductor products and chemical analysis businesses are now part of Agilent Technologies. We have made no changes to this manual copy. In other documentation, to reduce potential confusion, the only change to product numbers and names has been in the company name prefix: where a product number/name was HP XXXX the current name/number is now Agilent XXXX. For example, model number HP8648A is now model number Agilent 8648A.

---

# Semiconductor Parameter Analyzer

---

## User's Task Guide

© Copyright Hewlett-Packard Company 1993 - 1995

All Rights Reserved.

Reproduction, adaptation, or translation without prior written permission is prohibited, except as allowed under the copyright laws.

HP Part Number  
04155-90010

#### **Printing History**

First edition, February 1994  
Second edition, December 1994  
Third edition, November 1995

Printed in Japan

MS-DOS® is U.S. registered trademark of Microsoft Corporation.

Lotus 1-2-3 is U.S. registered trademark of Lotus Development Corporation.

PageMaker is a trademark of Aldus Corporation.

#### **Product Warranty**

This Hewlett-Packard product is warranted against defects in material and workmanship for a period of one year from date of shipment. During the warranty period, Hewlett-Packard will, at its option, either repair or replace products which prove to be defective.

For warranty service or repair, this product must be returned to a service facility designated by Hewlett-Packard. Buyer shall prepay shipping charges to Hewlett-Packard and Hewlett-Packard shall pay shipping charges to return the product to Buyer. However, Buyer shall pay all shipping charges, duties, and taxes for products returned to Hewlett-Packard from another country.

Hewlett-Packard warrants that its software and firmware designated by Hewlett-Packard for use with an instrument will execute its programming instructions when properly installed on that instrument. Hewlett-Packard does not warrant that the operation of the instrument, or software, or firmware will be uninterrupted or error free.

#### **Limitation of Warranty**

The foregoing warranty shall not apply to defects resulting from improper or inadequate maintenance by Buyer, Buyer-supplied software or interfacing, unauthorized modifications or misuse, operation outside of the environment specifications for the products, or improper site preparation or maintenance.

No other warranty is expressed or implied. Hewlett-Packard specifically disclaims the implied warranties of merchantability and fitness for a particular purpose.

#### **Exclusive Remedies**

The remedies provided herein are the Buyer's sole and exclusive remedies. Hewlett-Packard shall not be liable for any direct, indirect, special, incidental, or consequential damages, whether based on contract, tort, or any other legal theory.

#### **Assistance**

Product maintenance agreements and other customer assistance agreements are available for Hewlett-Packard products.

For any assistance, contact your nearest Hewlett-Packard Sales Office.

#### **Certification**

Hewlett-Packard Company certifies that this product met its published specifications at the time of shipment [from the factory]. Hewlett-Packard further certifies that its calibration measurements are traceable to the **National Institute of Standards and Technology** [NIST], to the extent allowed by the Institute's calibration facility, and to the calibration facilities of other International Standards Organization members.

---

Yokogawa-Hewlett-Packard, Ltd.  
9-1, Takakura-Cho, Hachioji-Shi,  
Tokyo, 192 Japan

## Safety Summary

The following general safety precautions must be observed during all phases of operation, service, and repair of this instrument. Failure to comply with these precautions or with specific warnings elsewhere in this manual may impair the protection provided by the equipment. In addition it violates safety standards of design, manufacture, and intended use of the instrument. Hewlett-Packard Company assumes no liability for customer's failure to comply with these requirements.

### NOTE

HP 4155A/4156A comply with INSTALLATION CATEGORY II and POLLUTION DEGREE 2 defined in IEC 1010-1.  
HP 4155A/4156A are INDOOR USE products.

- **GROUND THE INSTRUMENT**

To minimize shock hazard, the instrument chassis and cabinet must be connected to an electrical ground. The power terminal and the power cable must meet International Electrotechnical Commission (IEC) safety standards.

- **DO NOT OPERATE IN AN EXPLOSIVE ATMOSPHERE**

Do not operate the instrument in the presence of flammable gases or fumes. Operation of any electrical instrument in such an environment constitutes a definite safety hazard.

- **KEEP AWAY FROM LIVE CIRCUITS**

Operation personnel must not remove instrument covers. Component replacement and internal adjustments must be made by qualified maintenance personnel. Do not replace components with power cable connected. Under certain conditions, dangerous voltages may exist even with the power cable removed. To avoid injuries, always disconnect power and discharge circuits before touching them.

- **DO NOT SERVICE OR ADJUST ALONE**

Do not attempt internal service or adjustment unless another person, capable of rendering first aid and resuscitation, is present.

- **DO NOT SUBSTITUTE PARTS OR MODIFY INSTRUMENT**

Because of the danger of introducing additional hazards, do not install substitute parts or perform any unauthorized modification to the instrument. Return the instrument to a Hewlett-Packard Sales and Service Office for services and repair to ensure that safety features are maintained.

- **DANGEROUS PROCEDURE WARNINGS**

Warnings, such as example below, precede potentially dangerous procedures throughout this manual. Instructions contained in the warnings must be followed.

### WARNING

Dangerous voltages, capable of causing death, are present in this instrument. Use extreme caution when handling, testing, and adjusting.

### Safety Symbols

The general definitions of safety symbols used on equipment or in manuals are listed below.



Instruction manual symbol: the product will be marked with this symbol when it is necessary for the user to refer to the instruction manual in order to protect against damage to the instrument.



Indicates dangerous voltage [terminals fed from the interior by voltage exceeding 1000 volts must be so marked].



Indicates earth [ground] terminal.



Frame or chassis terminal. A connection to the frame [chassis] of the equipment which normally includes all exposed metal structures.



Alternating current.



Direct current.



ON (Supply).

OFF (Supply).

The warning sign denotes a hazard. It calls attention to a procedure, practice, condition or the like, which, if not correctly performed or adhered to, could result in injury or death to personnel.

**CAUTION**

The caution sign denotes a hazard. It calls attention to an operating procedure, practice, condition or the like, which, if not correctly performed or adhered to, could result in damage to or destruction of part or all of the product.

**Herstellerbescheinigung**

GEÄUSCHEMISSION

Lpa < 70 dB  
am Arbeitsplatz  
normaler Betrieb  
nach DIN 45635 T. 19

**Manufacturer's Declaration**

ACOUSTIC NOISE EMISSION

Lpa < 70 dB  
operator position  
normal operation  
per ISO 7779

## **HIGH VOLTAGE SHOCK HAZARD**

The HP 4155A/4156A can force dangerous voltages (200 V for HPSMU, and 100 V for HRSMU and MPSMU) at the force, guard, and sense terminals. To prevent electric shock hazard, the following safety precautions must be observed during the use of the HP 4155A/4156A

- ◆ Use a three-conductor ac power cable to connect cabinet (if used) and HP 4155A/4156A to an electric ground (safety ground).
- ◆ If you do not use HP 16442A Test Fixture, make sure to connect the INTLK terminal to a switch that turns off when the shielding box access door is opened.
- ◆ Confirm periodically that INTLK function works normally.
- ◆ Before touching the connections of the force, guard, and sense terminals, turn the HP 4155A/4156A off and discharge any capacitors whenever possible. If you do not turn the HP 4155A/4156A off, complete "all" of the following items, regardless of any HP 4155A/4156A settings.
  - Set the SMU output switches to off.
  - Confirm that HIGH VOLTAGE indicator is not lit.
  - Open the shielding box access door (open the INTLK terminal).
  - Discharge any capacitors if the capacitance is connected to an SMU.
- ◆ Warn workers around the HP 4155A/4156A about dangerous conditions.

### 高電圧感電注意

HP 4155A/4156Aからは、危険電圧（HP SMUの場合最大±200 Vdc、MP SMUまたはHR SMUの場合最大±100 Vdc）がフォース、ガードまたはセンス端子に出力されることがあります。

感電事故防止のため、必ず以下の事柄を守ってください。

- ◆ 3極電源ケーブルを使用して、HP 4155A/4156Aを接地する。
- ◆ HP 16442Aテスト・フィクスチャを使用しない場合は、インターロック（INTLK）端子をシールド・ボックスの蓋が開いた時にオープンになるように接地する。
- ◆ インターロック機能が正常かどうか定期的にテストする。
- ◆ フォース、ガード、およびセンス端子からの接続部に触れる前に、HP 4155A/4156Aの電源を切る。また、測定系にキャパシタが接続されている場合、キャパシタを放電する。

電源を切らない場合は、以下の4事項を全て実施する。

- SMUの出力スイッチをオフにする。
  - 高電圧警告インジケータが消灯していることを確認する。
  - シールド・ボックスの蓋を開ける（インターロック端子をオープンにする）。
  - キャパシタがSMUに接続されているならば、キャパシタを放電する。
- ◆ 周囲のほかの作業者に対しても、高電圧危険に対する注意を徹底する。

## **PRECAUTIONS POUR COMMOTION A HAUTE TENSION**

Une tension dangereuse (max.  $\pm$  pour HPSMU; 200 Vdc, max.  $\pm$  pour HPSMU ou HRSMU; 100 Vdc) émanant du dispositif HP 4155A/4156A peut être sortie aux bornes de force, d'appareil de protection ou de détection. Les précautions suivantes doivent être observées contre commotion électrique accidentelle:

- ◆ Mettre à la terre le dispositif HP 4155A/4156A au moyen du câble d'alimentation tripolaire.
- ◆ En cas de hors service du dispositif d'essai, FIXTURE HP 16442A, connecter les bornes de verrouillage (INTLK) de façon à ce que soit ouverte lorsque le couvercle de la boîte de blindage est ouvert.
- ◆ Essayer périodiquement le fonctionnement normal de verrouillage.
- ◆ Avant de toucher la partie connexion à partir des bornes de force, d'appareil de protection et de détection, mettre hors tension le dispositif HP 4155A/4156A. Et, en cas de condensateurs connectés au circuit de mesure, décharger ces condensateurs.
- ◆ Lorsque l'alimentation n'est pas mise hors tension, les 4 instructions suivantes doivent être exécutées:
  - Mettre hors service le commutateur de sortie de SMU.
  - S'assurer que soit allumé l'indicateur d'alarme de la haute tension.
  - Ouvrir le couvercle de la boîte de blindage (Ouvrir les bornes de verrouillage).
  - En cas de condensateurs connectés à SMU, décharger les condensateurs.
- ◆ Alerter d'autres personnes autour de vous contre le danger de haute tension.



## **Achtung! Gefährliche Spannung**

Von den Geräeten HP 4155A/4156A koennen Spannungen an den Anschluessen "force, guard und sense" von bis zu 200 V ausgehen.

Um elektrischem Schlag vorzubeugen, ist bei der Benuetzung der Geräete HP 4155A/4156A folgendes zu beachten:

- ◆ Erden Sie die Geräete HP 4155A/4156A mittels dreiadriger Netzleitungen.
- ◆ Wenn keine Spannvorrichtung für den HP 16442A verwendet wird, schließen Sie die Verriegelungsklemme (INTLK) so an, daß der geöffnetem Deckel des Schutzkastens erbracht wird.
- ◆ Prüfen Sie regelmässig, um zu festzustellen, ob die Verriegelungsfunktion richtig arbeitet.
- ◆ Schalten Sie die Geräete HP 4155A/4156A aus, bevor Sie die Anschlusse "Force, Guard und Sense" beruehren. Kondensatoren entlade.

Wenn Sie die Geräete HP 4155A/4156A nicht ausschalten, fuehren Sie folgende Schritte aus, unabhængig von den Geräeteinstellungen:

- Den Ausgangsschalter des SMU ausschalten.
- Feststellen, ob die Warnlampe fuer Höchspannung erloschen ist.
- Den Deckel des Schutzkastens öffnen (Die Verriegelungsklemme öffnen).
- Am SMU angeschlossene Kondensatoren entladen.
- ◆ Zugang zum Pruefplatz zum Schutz Dritter sichern.

---

# Introduction

HP 4155A/4156A is an electronic instrument for measuring and analyzing the characteristics of semiconductor devices. This one instrument allows you to perform *both* measurement *and* analysis of measurement results.

## **highly accurate measurements.**

HP 4155A/4156A has four highly accurate source/monitor units (SMUs), two voltage source units (VSUs), and two voltage measurement units (VMUs). The HP 4156A is designed for Kelvin connections and has high-resolution SMUs (HRSMUs), so HP 4156A is especially suited for low resistance and low current measurements. You can measure voltage values with a resolution of  $0.2 \mu\text{V}$  by using the differential measurement mode of VMUs.

## **reliability testing.**

HP 4155A/4156A can perform *stress* testing. That is, can force a specified dc voltage or current for the specified duration.

Also, you can force ac stress by using pulse generator units (PGUs), which are installed in HP 41501A SMU/Pulse Generator Expander. The HP 41501A is attached to HP 4155A or HP 4156A, and can be equipped with a ground unit (GNDU), high power SMU (HPSMU), two medium power SMUs (MPSMUs), or two PGUs.

## **data storing and printing.**

HP 4155A/4156A can print and store, in addition to performing measurement and analysis. You can store measurement setup information, measurement data, and instrument setting information on a 3.5-inch diskette inserted into the disk drive of HP 4155A/4156A. And you can print the setting information and measurement results on a plotter or printer that is connected to HP 4155A/4156A.

## **remote control.**

HP 4155A/4156A can be controlled by an external controller via HP-IB by using remote control commands. These commands are based on Standard Commands for Programmable Instruments (SCPI), so you can easily develop measurement programs.

HP 4155A/4156A has internal HP Instrument BASIC, so you can develop and execute measurement programs by using the HP 4155A/4156A only, without using an external controller.

---

## In This Manual

This manual gives step-by-step instructions for performing common HP 4155A/4156A tasks, and consists of the following chapters:

**NOTE**

If you have never used the HP 4155A/4156A or HP 4145A/B, read the HP 4155A/4156A *Quick Start Guide* first before reading this manual. The *Quick Start Guide* gives you an overview of the product and a brief introduction, which is a good first step for beginners.

- Introducing the HP 4155A/4156A

This chapter is an overview of the HP 4155A/4156A.

- Installation

This chapter describes how to install HP 4155A/4156A, accessories, and peripherals.

- Making a Measurement

This chapter describes device connections, making a sweep measurement, knob sweep measurement, and sampling measurement, and forcing stress.

- Analyzing Measurement Results

This chapter describes how to analyze measurement results manually and automatically.

- Filer and Hardcopy

This chapter describes how to print or plot out measurement results or measurement setups.

- If You Have a Problem

This chapter provides problem-solving information that you may encounter.

- Manual Changes Depending on ROM Version
- Index

### **Other Manuals.**

Also the following manuals about HP 4155A/4156A are available:

- User's Dictionary Reference

This manual is a dictionary reference for all parts and functions of the HP 4155A/4156A, and consists of the following chapters:

- Measurement Units
- Measurement Mode
- Measurement Functions
- Page Organization
- Print/Plot Function
- Data Variable and Analysis Function
- Softkey Maps and External Keyboard
- Specifications
- Accessories and Options
- Manual Changes Depending on ROM Version
- Index

- Programmer's Guide

This manual provides information about controlling the HP 4155A/4156A by remote command via HP-IB interface and HP Instrument BASIC, and consists of the following chapters:

- Using HP Instrument BASIC
- Reference: HP Instrument BASIC
- Getting Started on Programming the HP 4155A/4156A
- HP 4155A/4156A SCPI Programming
- Running HP 4145A/B Program Directly on HP 4155A/4156A
- Sample Application Programs
- Manual Chages Depending on ROM Version

- HP-IB Command Reference

This manual is a complete reference of HP-IB commands, and consists of the following chapters:

- SCPI Commands
- HP 4145B Syntax Commands
- Manual Changes Depending on ROM Version
- Index

- Quick Start Guide

This manual is mainly for beginners and provides brief instructions about using HP 4155A/4156A.

### **Text Conventions.**





The following text conventions are used in this manual:

<b>Front-panel key</b>	Represents a key physically located on HP 4155A/4156A or external keyboard.
<b>Softkey</b>	Represents a softkey that appears on screen of HP 4155A/4156A.
<b>Screen Text</b>	Represents text that appears on screen of HP 4155A/4156A.
<i>Italic</i>	Refers to a related document, or is used for emphasis.

---

# Contents

## 1. Introducing the HP 4155A/4156A

Overview of HP 4155A/4156A . . . . .	1-3
Configuration of HP 4155A/4156A and HP 41501A . . . . .	1-4
Front View of HP 4155A/4156A . . . . .	1-5
Rear View of HP 4155A/4156A . . . . .	1-9
 . . . . .	1-10
 . . . . .	1-10
 . . . . .	1-11
Front and Rear View of HP 41501A . . . . .	1-12
 . . . . .	1-13
An Overview of Functions . . . . .	1-19
Operation and Control . . . . .	1-20
Measurements and Results Display . . . . .	1-22
Graphical Analysis . . . . .	1-25
Data Storage . . . . .	1-26
Plotting and Printing . . . . .	1-27

## 2. Installation

 . . . . .	2-2
Requirements . . . . .	2-3
Power Requirements . . . . .	2-4
Power Cable . . . . .	2-5
Ventilation Requirements . . . . .	2-7
Operating Environment . . . . .	2-7
Cleaning . . . . .	2-7
Setting up HP 4155A/4156A . . . . .	2-8
To Inspect HP 4155A/4156A and Accessories . . . . .	2-8
To Install HP 41501A SMU/Pulse Generator Expander . . . . .	2-9
To Check HP 4155A/4156A Operation . . . . .	2-10
Installing Accessories . . . . .	2-12
To Install Connector Plate . . . . .	2-13
To Connect Interlock Terminal . . . . .	2-17

## Change 1

To Connect Connector Plate and DUT . . . . .	2-22
To Install HP 16442A Test Fixture . . . . .	2-29
To Install HP 16441A R-Box . . . . .	2-35
To Install HP 16440A SMU/Pulse Generator Selector . . . . .	2-38
To Connect HP 16440A Selector to HP 4155A/56A . . . . .	2-45
<b>3. Making a Measurement</b>	
Connection to Device Under Test (DUT) . . . . .	3-3
To Mount a DUT on Test Fixture . . . . .	3-4
To Make Connections to Reduce Leakage Current . . . . .	3-6
To Make Connections to Measure Low Resistance (For HP 4156A Only) . . . . .	3-8
Sweep Measurements . . . . .	3-10
To Define Sweep Measurement Units . . . . .	3-12
To Set up Primary Sweep Source . . . . .	3-14
To Set up Secondary Sweep Source . . . . .	3-16
To Set up Synchronous Sweep Source . . . . .	3-18
To Set up Constant Output . . . . .	3-20
To Set up SMU Pulsed Output . . . . .	3-21
To Set up PGU Pulsed Output . . . . .	3-24
To Output Same Value Before and After Measurements . . . . .	3-27
To Define a User Function . . . . .	3-28
To Set up Graphical Display of Measurement Results . . . . .	3-30
To Set up List Display of Measurement Results . . . . .	3-32
To Execute or Stop Measurement . . . . .	3-33
To Control R-Box . . . . .	3-34
Knob Sweep Measurements . . . . .	3-37
To Execute Knob Sweep Measurement . . . . .	3-38
To Stop Knob Sweep Measurement . . . . .	3-42
Sampling Measurements . . . . .	3-43
To Define Sampling Measurement Units . . . . .	3-45
To Set up Sampling Parameters . . . . .	3-47
To Set up Constant Output . . . . .	3-49
To Define Measurement Stop Conditions . . . . .	3-51
Stress Force . . . . .	3-53
To Set up Stress Source Channels . . . . .	3-55
To Set up Stress Condition/Timing . . . . .	3-57
To Set up AC (Pulse) Stress . . . . .	3-60
To Set up DC Stress . . . . .	3-62
To Force Stress . . . . .	3-64
To Control Selector for Switching SMU and PGU . . . . .	3-66

**4. Analyzing Measurement Results**

Manual Analysis . . . . .	4-3
To Specify a Measurement Point on Curve . . . . .	4-4
To Specify between Measurement Points on Curve . . . . .	4-6
To Display or Move Cursor . . . . .	4-8
To Adjust Display Range to Measurement Curve Automatically . . . . .	4-10
To Zoom the Display Range . . . . .	4-11
To Center Display at Cursor Location . . . . .	4-12
To Draw Line through Two Specified Points . . . . .	4-13
To Draw Line through Specified Point with Specified Gradient . . . . .	4-15
To Draw Tangent to Specified Point of Measurement Curve . . . . .	4-17
To Draw Regression Line for Specified Region . . . . .	4-19
To Display and Select a Line . . . . .	4-22
To Display Grid on the Graph . . . . .	4-23
To Change Data Variable on Graph . . . . .	4-24
To Change Range of X or Y Axis Scale . . . . .	4-25
To Change Variable Assigned to X, Y1, or Y2 Axis . . . . .	4-26
To Overlay an Internal Memory Measurement Curve onto Plotting Area . . . . .	4-27
To Scroll the LIST Page . . . . .	4-29
To Display or Move Marker on LIST Page . . . . .	4-30
To Change Variables of LIST page . . . . .	4-32
Automatic Analysis . . . . .	4-33
To Draw Line by Specifying Two Points . . . . .	4-34
To Draw Line by Specifying Gradient and One Point . . . . .	4-36
To Draw Tangent to Specified Measurement Point . . . . .	4-38
To Draw Regression Line by Specifying Two Points . . . . .	4-40
To Display Marker at Specified Point . . . . .	4-43

**5. Filer**

File Operations . . . . .	5-3
To List File Names Stored on Diskette . . . . .	5-5
To Store Setup or Result Data onto Diskette . . . . .	5-7
To Store Setup or Result Data into Internal Memory . . . . .	5-9
To Store Result Data in Spreadsheet Format . . . . .	5-11
To Load Setup or Result Data from Diskette . . . . .	5-13
To Load Setup or Result Data from Internal Memory . . . . .	5-16
To Rename a File on Diskette . . . . .	5-18



## Change 1

To Remove a File from Diskette . . . . .	5-19
To Copy File on Diskette to Another Diskette . . . . .	5-21
To Copy Setup or Result Data from Internal Memory to Diskette . . . . .	5-23
To Initialize a Diskette . . . . .	5-24
To Backup a Diskette . . . . .	5-26

## 6. If You Have A Problem

When You Install the HP 4155A/4156A . . . . .	6-4
If HP 4155A/4156A cannot be Powered on . . . . .	6-5
If Measurement Units of HP 41501A are not Displayed on the CHANNELS: CHANNEL DEFINITION Page . . . . .	6-6
If External Keyboard does not Work . . . . .	6-7
If Display Page does not Appear after Applying Power . . . . .	6-7
If HP 16442A Test Fixture is not Stable . . . . .	6-7
When You Make A Measurement . . . . .	6-8
If Measured Value Oscillates when Measuring High-Frequency Devices . . . . .	6-9
If Measured Value Oscillates when Measuring Negative Resistance . . . . .	6-10
If Noise Affects the Measured Values . . . . .	6-12
If Measured Voltage has some Error when Forcing a Large Current . . . . .	6-13
If Large Current Causes High Temperature (Thermal Drift) . . . . .	6-13
If Measurement Takes More Time than Specified . . . . .	6-14
If Measurement Damages the Device under Test . . . . .	6-14
If You Get Unexpected Data when Performing Sampling Measurement . . . . .	6-15
If Errors Occur . . . . .	6-16
If Errors Occur when You Perform Self-calibration or Diagnostics . . . . .	6-17
If an error occurs when you operate HP 4155A/4156A . . . . .	6-25
If a Measurement Data Status is Displayed . . . . .	6-40

## 7. Manual Changes Depending on ROM Version

Change 1 . . . . .	7-3
--------------------	-----

## Index

---

## Figures

1-1. Front View of HP 4155A/4156A . . . . .	1-5
1-2. Rear View of HP 4155A/4156A . . . . .	1-9
1-3. Front and Rear View of HP 41501A . . . . .	1-12
1-4. Rear View of HP 41501A Option 402 . . . . .	1-14
1-5. Rear View of HP 41501A Option 410 . . . . .	1-15
1-6. Rear View of HP 41501A Option 412 . . . . .	1-16
1-7. Rear View of HP 41501A Option 420 . . . . .	1-17
1-8. Rear View of HP 41501A Option 422 . . . . .	1-18
2-1. Power Cables . . . . .	2-5
2-2. Dimensions of Connector Plate for HP 4155A (HP Part Number: 04155-60006) . . . . .	2-14
2-3. Dimensions of Connector Plate for HP 4156A (HP Part Number: 04156-60002) . . . . .	2-15
2-4. Dimensions of Connector Plate for HP 41501A (HP Part Number: 41501-60004) . . . . .	2-16
2-5. Dimensions of Interlock Switch (HP part number 3101-0302) . . . . .	2-20
2-6. Dimensions of Interlock Switch (HP part number 3101-3241) . . . . .	2-20
2-7. Dimensions of LED (HP part number 1450-0641) . . . . .	2-21

---

## Tables

1-1. Configuration of HP 41501A . . . . .	1-4
2-1. Connectors on Connector Plate . . . . .	2-15

## Contents

---

**Introducing the HP  
4155A/4156A**

---

## Introducing the HP 4155A/4156A

The HP 4155A semiconductor parameter analyzer and HP 4156A precision semiconductor parameter analyzer are made for use in semiconductor laboratories and factories. The HP 4155A/4156A can measure device characteristics. The HP 4155A/4156A can do the following:

- Perform measurements.
- Graph the device characteristics.
- Extract device parameters.
- Perform go, no-go evaluation.
- Perform reliability (stress test) evaluation.

The HP 4155A/4156A is easy to operate and can perform automatic graphical analysis like the HP 4145B. In addition, the HP 4155A/4156A is also easy to use in a system, which expands areas of application to quality assurance and in-line monitoring.

**In this chapter.**

This chapter provides a view of front and rear panels of the HP 4155A/4156A and its accessories, and briefly describes the HP 4155A/4156A functions.

---

## Overview of HP 4155A/4156A

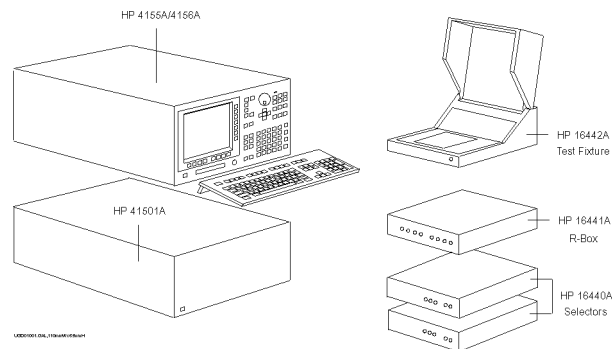

HP 4155A/4156A is a box type electronic measurement instrument with CRT display, flexible disk drive, operation keys, and interface connectors.

You can connect a keyboard (HP C1405B) to the HP 4155A/4156A. So, you can operate this instrument by using a keyboard or the front-panel keys.

HP 16442A is the test fixture for HP 4155A/4156A. You can mount your DUT on the HP 16442A, and measure the device characteristics.

HP 41501A SMU and pulse generator expander contains PGUs and additional SMUs. HP 41501A is attached to and controlled by HP 4155A/4156A.

HP 16441A R-Box contains accurate 10 k $\Omega$ , 100 k $\Omega$ , and 1 M $\Omega$  resistors, and connection of these resistors is controlled by the HP 4155A/4156A. The HP 16441A is used to measure negative resistance and to prevent DUT damage when performing breakdown measurements.

HP 16440A SMU/pulse generator selector contains two switching circuits to connect the DUT to either an SMU or PGU. You can attach another HP 16440A to add two more switching circuits.

---

## Configuration of HP 4155A/4156A and HP 41501A

HP 4155A, HP 4156A, and HP 41501A are frames that contain the measurement units. The measurement units are installed before the product is shipped from factory. User cannot reconfigure the installed units.

- HP 4155A configuration:
  - four medium power source monitor units (MPSMUs).
  - two voltage source units (VSUs).
  - two voltage monitor units (VMUs).
- HP 4156A configuration:
  - four high resolution source monitor units (HRSMUs).
  - two voltage source units (VSUs).
  - two voltage monitor units (VMUs).

HP 4156A has higher measurement resolution. For details about measurement range and resolution, refer to “Measurement Units” in *HP 4155A/4156A User’s Dictionary Reference*.

- HP 41501A configuration:

HP 41501A is attached to the HP 4155A/4156A at your site. See Chapter 2 on how to install the HP 41501A.

The HP 41501A contains a ground unit (GNDU). In addition, you specify an option number according to desired units as follows:

**Table 1-1. Configuration of HP 41501A**

Unit	HP 41501A Option ...				
	402	410	412	420	422
One GNDU	•	•	•	•	•
Two PGUs	•		•		•
Two MPSMUs				•	•
One HPSMU <sup>1</sup>		•	•		

<sup>1</sup> HPSMU: high power source monitor unit

---

## Front View of HP 4155A/4156A

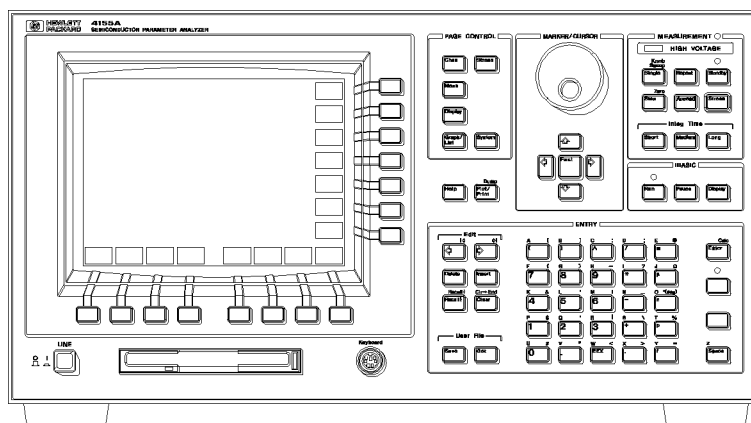

**Figure 1-1. Front View of HP 4155A/4156A**

**LINE switch.**

Use the LINE switch to turn analyzer on and off.

**Flexible disk drive (FDD).**

Use 3.5 inch diskette to load or store the analyzer settings and measurement data.

**Keyboard connector.**

You can use an IBM PC/AT compatible keyboard (HP C1405B) to operate the HP 4155A/4156A. See "Softkey Maps and External Keyboard" in *HP 4155A/4156A User's Dictionary Reference*.



**Overview of HP 4155A/4156A**

**PAGE CONTROL key group.**

Page Control keys are used to change the pages.



- Chan** Moves to CHANNELS page group. You define channels, user functions, and user variables.
- Meas** Moves to MEASURE page group. You set the output parameters, measurement parameters, and so on.
- Display** Moves to DISPLAY page group. You set the result display format, auto analysis definitions, and so on.
- Graph/List** Moves to GRAPH/LIST page group. This softkey toggles between GRAPH and LIST pages.
- Stress** Moves to STRESS page group. You define the stress channels, set the stress parameters, and monitor the stress forcing.
- System** Moves to SYSTEM page group. You operate on diskette files, set up plotting and printing environment, define colors of the display, and so on.

**MARKER/CURSOR key group.**

Rotary knob and arrow keys of the Marker/Cursor key group are used to move the marker and cursor.

Rotary knob Moves the marker, or increases or decreases setup value.

, , Moves field pointer or cursor.

, and 

**Fast** Moves the marker or cursor faster. When you rotate the rotary knob or press the arrow keys with holding **Fast** key down, the marker or cursor moves faster.

### **MEASUREMENT key group.**

Measurement keys control the measurement, stress, and integration time.

- Single** Executes the measurement once, then returns to the idle state (or standby state if standby is enabled for the channel) after the measurement is finished. Measurement data is updated, so data of previous measurement is lost. Pressing the green key, then **Single** key starts *knob sweep* measurement.
- Repeat** Starts and repeats the measurement continuously. Measurement data is updated, so data of previous measurement is lost. To stop the measurement, press **Stop** key.
- Append** Executes the measurement once, then returns to idle state (or standby state if standby is enabled for the channel) after measurement is finished. Measurement data is appended to data of previous measurement.
- Stop** Stops the measurement or stress. Standby enabled channels return to standby state, and other channels return to idle state.
- Standby** Toggles between the standby enabled (Standby indicator is lit) and disabled states. If Standby indicator is lit, then **STBY ON** channels change to standby state (instead of idle state) when measurement or stress finishes. **Stop** key has no affect on standby state.
- Stress** Forces the specified stress. The guide around this key prevents you from accidentally pressing the **Stress** key.
- Short**,  
**Medium**,  
and **Long** Sets the integration time to SHORT, MEDIUM, or LONG, respectively.

### **MEASUREMENT indicator.**

This indicator lights when HP 4155A/4156A is in the measurement state.

### **HIGH VOLTAGE indicator.**

This indicator lights when a unit forces more than 40 V.

### **Standby indicator.**

This indicator lights when the HP 4155A/4156A is standby enabled, which means that the channels that are standby enabled (**STBY ON**) will return to the standby state after the measurement is finished.

**Overview of HP 4155A/4156A**

**IBASIC key group.**

IBASIC keys control the IBASIC program execution.

- Run** Starts the IBASIC program that is in memory. The indicator is on during program execution.
- Pause** Pauses the IBASIC program execution.
- Display** Toggles between the IBASIC screen and measurement screen.

**Run indicator.**

When an IBASIC program is running, this indicator lights.

**ENTRY key group.**

You enter or modify data such as output values, comments, and variable names.

Character keys Are used to enter alphanumeric and special characters.

- Enter** After you enter desired characters into the data entry field, press this key. The characters are entered at the field pointer location.  
Also, you can use the green key to calculate the value of the data entry field. For example, if you press **4** **\*** **6** greenkey **Enter**, the result (24) appears.

Blue key Changes entry mode to blue-key shift mode, and lights the indicator. In this mode, you can enter the blue characters that are printed above the keys. Pressing blue key again changes to normal mode. Indicator turns off.

Green key Changes entry mode to green-key shift mode. This mode is effective for the next pressed key, then changes back to normal mode.

Edit keys Are used to edit the characters in the data entry field.

User File keys Are used to operate quickly on a diskette file. Pressing **Save** moves into the filer's SAVE function, and pressing **Get** moves into the filer's GET function.

**Help key.**

Pressing **Help** displays the *help* pages.

**Plot/Print key.**

Pressing **Plot/Print** prints the setup information and measurement results to your plotter, printer, or diskette file. If you press green key and **Plot/Print**, the screen image is dumped to plotter, printer, or diskette file.

## Rear View of HP 4155A/4156A

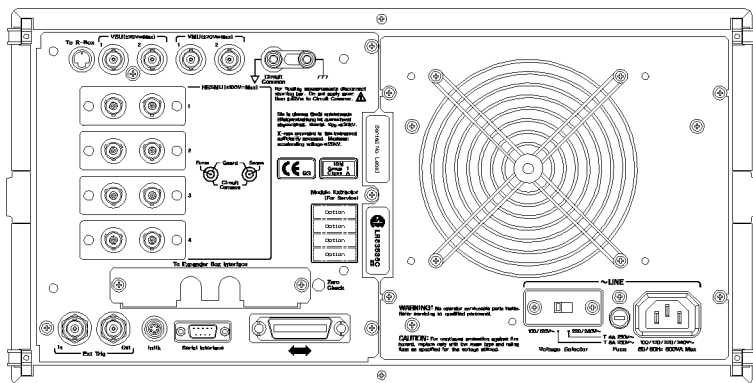
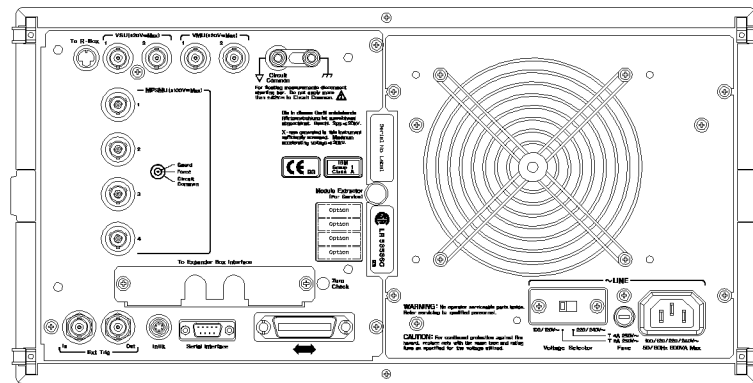

Figure 1-2. Rear View of HP 4155A/4156A

Introducing the HP 4155A/4156A

## Overview of HP 4155A/4156A

### To R-Box terminal.

“To R-Box” terminal is a 10-pin connector. To use R-Box, connect this terminal to control terminal of HP 16441A R-Box.

### VSU terminals.

VSU output terminals are BNC connectors. To use VSUs, connect these terminals to VSU terminals of HP 16442A or connector plate.

### VMU terminals.

VMU input terminals are BNC connectors. To use VMUs, connect these terminals to VMU terminals of HP 16442A or connector plate.



### Circuit Common () and Frame ground () terminals.

For floating measurement, remove the shorting bar (HP part number 5000-4206).

---

## WARNING

---

Do not float the Circuit Common terminal at voltages greater than  $\pm 42$  V referenced to frame ground. Failure to heed this warning may result in damage to HP 4155A/4156A.

### Serial number.

You need this *serial number* when using the telephone assistance program (HP HelpLine).

### Voltage selector.

Voltage selector must be in proper position. Line voltage and position are:

<u>Line Voltage</u>	<u>Position</u>
90–132 Vac	left
198–264 Vac	right



### Fuse.

Use the following fuse:

<u>Line</u>	<u>Fuse type</u>	<u>HP part number</u>
100/120 Vac	UL/CSA T 8A, 250 Vac	2110-0383
220/240 Vac	UL/CSA T 4A, 250 Vac	2110-0014

### LINE input receptacle.

AC power cable is connected to this receptacle.

**SMU terminals.**

HP 4155A has four triaxial connectors. HP 4156A has eight triaxial connectors, and you can use Kelvin connections. When you use HP 16442A test fixture and Kelvin connections, up to 3 SMUs can be connected to HP 16442A test fixture.

**To Expander Box Interface.**

When you use HP 41501A, you insert the board for HP 41501A into this interface.

**Zero Check terminal.**

Ground reference point of the HP 4155A/4156A.

**Ext Trig terminals.**

Two BNC connectors: one for trigger input, and one for trigger output.



**Intlk terminal.**

Used in conjunction with interlock function of HP 4155A/4156A. If the Intlk terminal is open, maximum SMU output is limited to  $\pm 40$  V. Be sure to connect this terminal to HP 16442A test fixture or connector plate before performing measurement. If you use connector plate, you must install interlock circuit. For details on how to install the interlock circuit, see "To Connect Interlock Terminal" in Chapter 2.

---

**WARNING**

---

Dangerous voltage of up to the maximum voltage of SMUs may be present at force, guard, and sense terminals if the interlock terminal is shorted.

**Serial Interface connector.**

9-pin female connector for RS-232-C serial communication.

**HP-IB connector.**

Use HP 10833A/B/C/D HP-IB cable.

Introducing the HP 4155A/4156A  
**Overview of HP 4155A/4156A**

---

Front and Rear View of HP 41501A

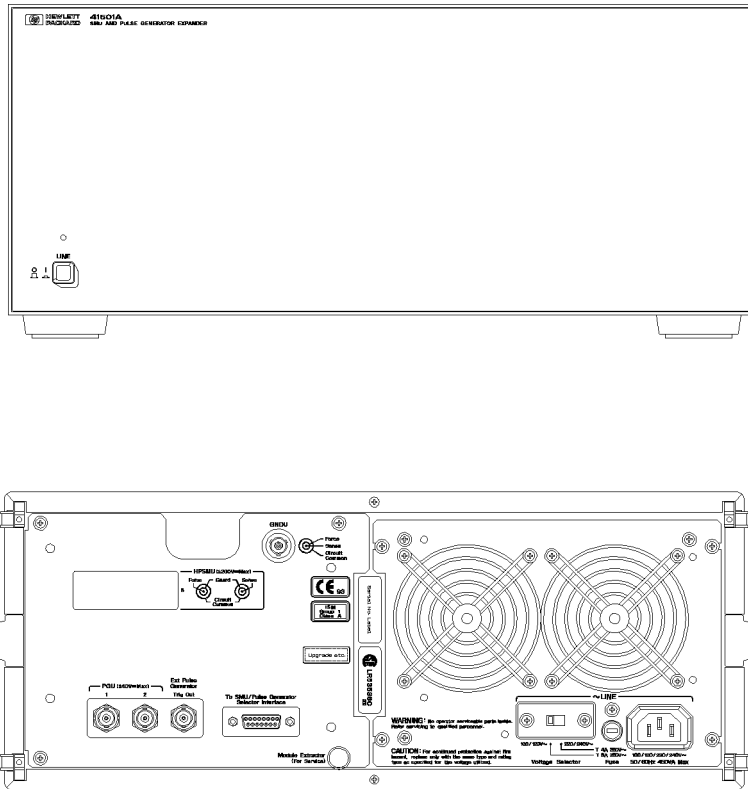

**Figure 1-3. Front and Rear View of HP 41501A**

**LINE switch.**

Use the LINE switch to turn HP 41501A on and off. *You must turn on the HP 41501A before turning on the HP 4155A/4156A.*



**Fuse.**

Use the following fuse:

<u>Line</u>	<u>Fuse type</u>	<u>HP part number</u>
100/120 Vac	UL/CSA T 8A, 250 Vac	2110-0383
220/240 Vac	UL/CSA T 4A, 250 Vac	2110-0014

**Voltage Selector.**

Voltage selector must be in proper position. Line voltage and position are:

<u>Line Voltage</u>	<u>Position</u>
90—132 Vac	left
198—264 Vac	right

**LINE input receptacle.**

AC power cable is connected to this receptacle.

**Serial number.**

The HP 41501A has its own serial number. You need this *serial number* when using the telephone assistance program (HP HelpLine).

**GNDU connector.**

The GNDU connector is a triaxial connector: inner conductor is sense, middle conductor is force, and outer conductor is circuit common.



Introducing the HP 4155A/4156A  
**Overview of HP 4155A/4156A**

Option 402

HP 41501A Option 402 has two PGUs.

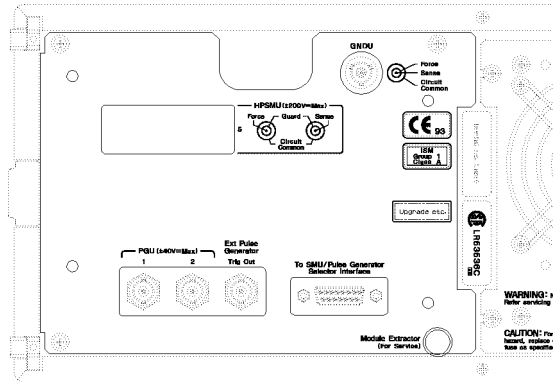

**Figure 1-4. Rear View of HP 41501A Option 402**

**PGU output terminals.**

BNC connectors. Inner conductor is force and outer conductor is circuit common.

**Ext Pulse Generator Trig Out terminal.**

Trigger pulses synchronized with PGU pulses are output. This trigger is used to synchronize the PGU pulse outputs with external pulse generators. You *cannot* change the parameters of this trigger. For details about PGU trigger, see "Measurement Functions" in *HP 4155A/4156A User's Dictionary Reference*.

**To SMU/Pulse Generator Selector Interface.**

D-SUB 15-pin connector is used to control the HP 16440A SMU/pulse generator selector.

Introducing the HP 4155A/4156A  
**Overview of HP 4155A/4156A**

Option 410

HP 41501A Option 410 has one HPSMU.

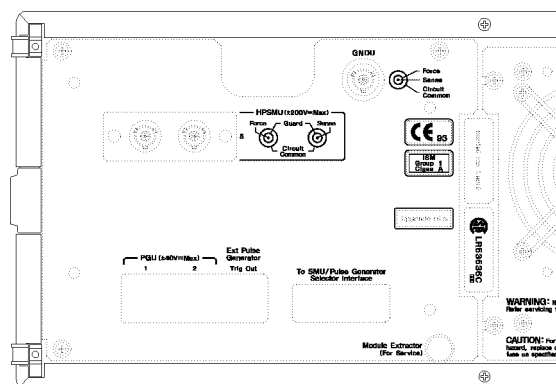

**Figure 1-5. Rear View of HP 41501A Option 410**

**HPSMU terminals.**

There are two triaxial connectors for Kelvin connections: one is for force and the other is for sense.

Introducing the HP 4155A/4156A  
**Overview of HP 4155A/4156A**

Option 412

HP 41501A Option 412 has one HPSMU and two PGUs.

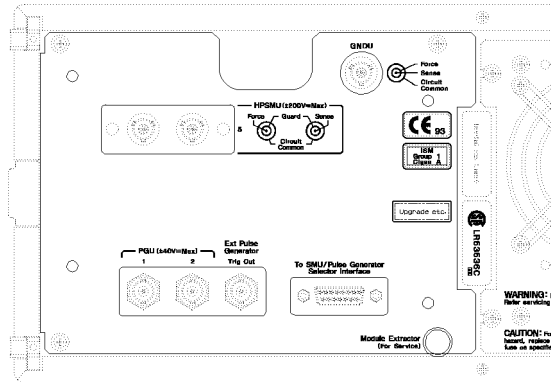

**Figure 1-6. Rear View of HP 41501A Option 412**

**HPSMU terminals.**

There are two triaxial connectors for Kelvin connections: one is for force and the other is for sense.

**PGU output terminals.**

BNC connectors. Inner conductor is force and outer conductor is circuit common.

**Ext Pulse Generator Trig Out terminal.**

Trigger pulses synchronized with PGU pulses are output. This trigger is used to synchronize the PGU pulse outputs with external pulse generators. You *cannot* change the parameters of this trigger. For details about PGU trigger, see “Measurement Functions” in *HP 4155A/4156A User’s Dictionary Reference*.

**To SMU/Pulse Generator Selector Interface.**

D-SUB 15-pin connector is used to control the HP 16440A SMU/pulse generator selector.

Option 420

HP 41501A Option 420 has two MPSMUs.

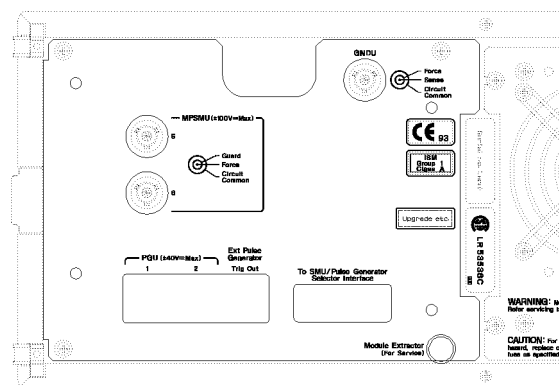

**Figure 1-7. Rear View of HP 41501A Option 420**

**MPSMU terminals.**

Two MPSMUs are installed and each MPSMU has a triaxial connector. But these connectors are not designed for Kelvin connections.

Introducing the HP 4155A/4156A  
**Overview of HP 4155A/4156A**

Option 422

HP 41501A Option 422 has two MPSMUs and two PGUs.

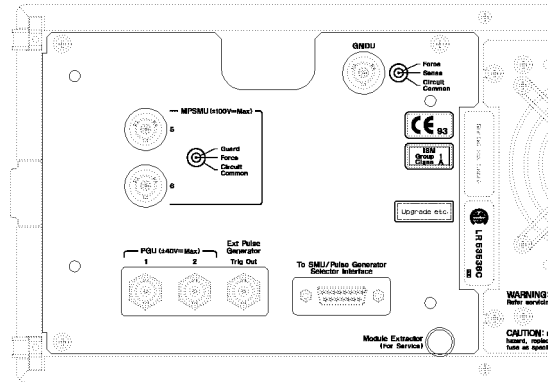

Figure 1-8. Rear View of HP 41501A Option 422

**MPSMU terminals.**

Two MPSMUs are installed and each MPSMU has a triaxial connector. These connectors are not designed for Kelvin connections.

**PGU output terminals.**

BNC connectors. Inner conductor is force and outer conductor is circuit common.

**Ext Pulse Generator Trig Out terminal.**

Trigger pulses synchronized with the PGU pulses are output. This trigger is used to synchronize the PGU pulse outputs with external pulse generators. You *cannot* change the parameters of this trigger. For details about PGU trigger, see “Measurement Functions” in *HP 4155A/4156A User’s Dictionary Reference*.

**To SMU/Pulse Generator Selector Interface.**

D-SUB 15-pin connector is used to control the HP 16440A SMU/pulse generator selector.

---

## An Overview of Functions

HP 4155A/4156A has the following useful functions.

- Operation and control
- Measurements and results display
- Graphical analysis
- Data storage
- Plotting and printing

Introducing the HP 4155A/4156A

## **An Overview of Functions**

---

## Operation and Control

You operate HP 4155A/4156A from the front-panel keys. Also, you can attach a keyboard (HP C1405B) to HP 4155A/4156A, and operate it from keyboard. See “Softkey Map and External Keyboard” in *HP 4155A/4156A User's Dictionary Reference*.

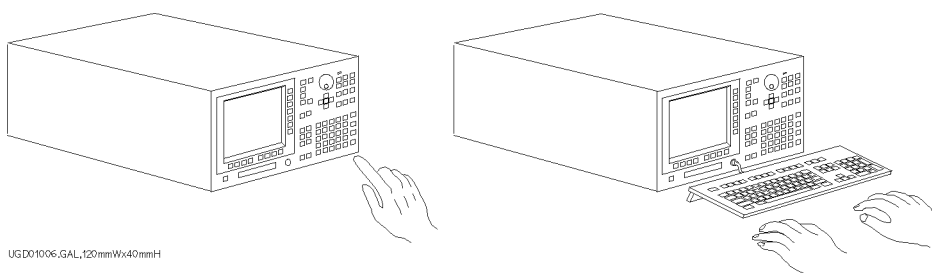

HP 4155A/4156A is operated by a “form fill-in” method. That is, the user-interface consists of setup and results pages, and you fill in fields on appropriate pages to select a measurement mode, set measurement parameters and conditions, set results display mode, and so on. After you execute the measurement, measurement results are displayed on result pages.

When you operate from the front panel, the basic page flow is as follows:

1. channel definition
2. source setup
3. display setup
4. results display

Also, HP 4155A/4156A can be controlled via HP-IB by external controller, such as an HP 9000 computer. To control HP 4155A/4156A, you create a control (measurement) program by using a programming language such as HP BASIC. The measurement program uses remote control commands of the HP 4155A/4156A. These are easy-to-understand commands based on Standard Commands for Programmable Instruments (SCPI).

Introducing the HP 4155A/4156A  
**An Overview of Functions**

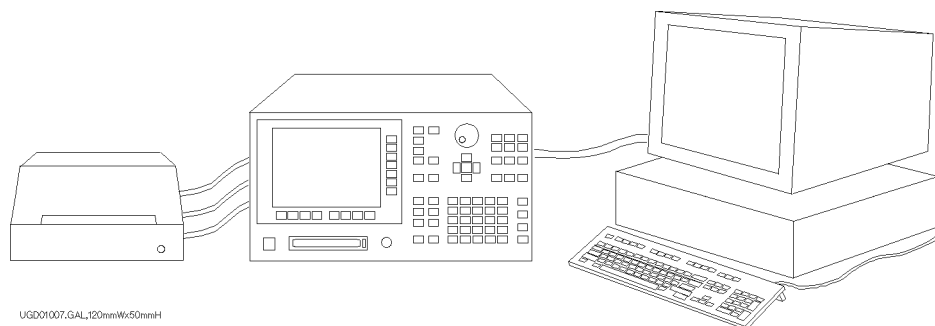

UGD01007.GAL\_120mmWx50mmH

The HP 4155A/4156A has a built-in HP Instrument BASIC (IBASIC) environment. You can create a measurement program using IBASIC to control the HP 4155A/4156A instead of using an external controller. This eliminates the need for an external controller, so required working space is reduced.

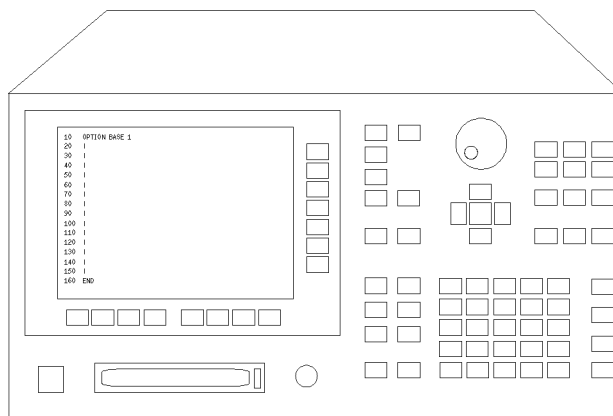

UGD01008.GAL\_200mmWx50mmH

When you develop measurement programs using the built-in HP Instrument BASIC environment of the HP 4155A/4156A, you use the HP 4155A/56A remote commands. See the HP 4155A/4156A *Programmer's Guide* and *HP-IB Command Reference*.



---

## Measurements and Results Display

You set up the fields on the setup pages of HP 4155A/4156A, then perform the measurement. After measurement, you can display the measurement results on the GRAPHICS or LIST page.

### Measurement.

The HP 4155A/4156A can perform two types of measurements: sweep measurement and sampling measurement. These two types of measurements *cannot* be executed at the same time.

- Sweep measurement

For sweep measurements, an SMU or a VSU can become a primary sweep source, secondary sweep source, synchronous sweep source, or constant source.

For example, you can perform sweep measurements to get an  $I_c$ - $V_{ce}$  curve of a bipolar transistor as in the following example:

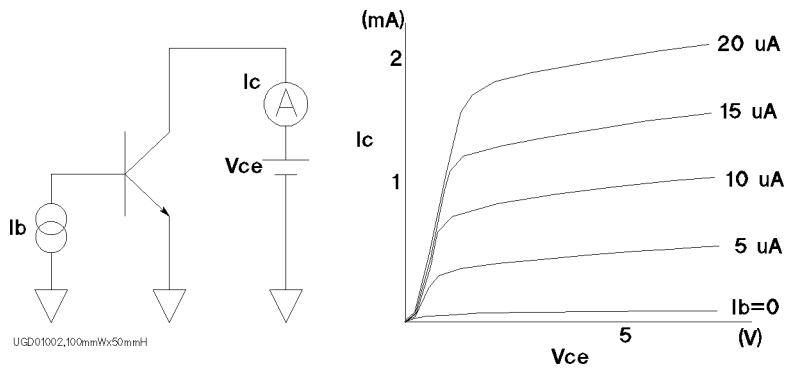

In the example above, a primary source ( $V_{ce}$ ) and a secondary source ( $I_b$ ) are defined. After primary sweep source finishes each sweep, the secondary sweep source outputs the next value.

- Sampling measurements

For sampling measurements, the source units output constant values, and measurements are executed by each unit at the specified intervals.

For example, you can get an integration curve of an RC integrator by sampling measurement as follows:

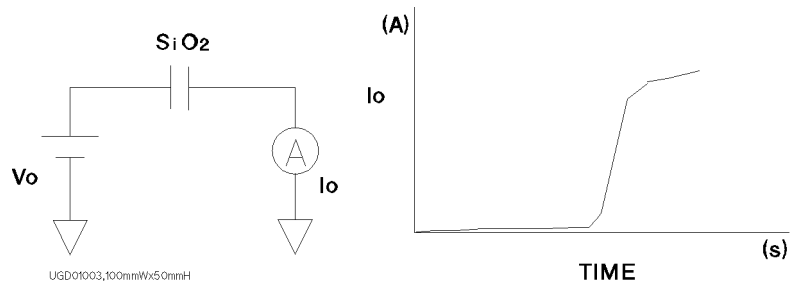

In the example above, measurements by the monitor unit start when the source unit outputs the specified value.

## **An Overview of Functions**

### **Setup pages.**

You set the measurement mode, parameters, and conditions by filling in the blank fields on the appropriate pages. You can enter variable names for the output and measurement values, and you can define more complex variables called user functions. For example, you can specify a variable name for the forward current, such as “If”, and refer to this variable on other pages instead of the unit name.

### **Results display.**

You can display measurement results on the screen in graphics or list style. When measurement starts, the results page appears according to the display setting information that you set. Of course, the HP 4155A/4156A plots or displays the results as the measurement progresses. You can also modify the measurement parameters and conditions on the results page without returning to the setup page.

### **Knob sweep.**

For knob sweep measurement, you can vary the sweep range by rotating the rotary knob. The knob sweep function is useful when you need to quickly make a rough measurement of your DUT characteristics. You only need to define the channel assignments, then you can start the knob sweep measurement. You can also change parameters and conditions by using secondary softkeys on the knob sweep page, and you can easily copy these changes so that they will be used in the normal sweep mode.

### **Stress.**

HP 4155A/4156A can force stress to your DUT for a specified duration. You can set the stress force parameters and channels independently from the measurement channels. And the stress duration is controlled accurately. You can force dc stress, and also ac stress because the HP 41501A can be equipped with pulse generators. You can perform reliability evaluations by repeating the stress-measurement cycle.

## Graphical Analysis

You can analyze the measurement results graphically by using a marker and two lines. The marker can move on the measurement curve only, so you can read the measurement values by reading the marker coordinates. You can draw up to two lines on plotting area by following methods:

- Normal line: through two points that are specified by cursors.
- Gradient line: through one point specified by cursor with specified gradient.
- Tangent line: tangent to point specified by marker on measurement curve.
- Regression line: regression line for area specified by two cursors.

X/Y intercept values and gradient of each line are automatically displayed, so you can get values such as threshold voltage ( $V_{th}$ ) and Early voltage ( $V_A$ ).

Also, you can setup the auto-analysis page to position marker and lines at desired location automatically after measurement finishes. For example, you can automatically find threshold voltage ( $V_{th}$ ) as follows:

1.  $V_g$  versus  $\sqrt{I_d}$  curve, and  $V_g$  versus  $\frac{\partial}{\partial V_g} \sqrt{I_d}$  curve are drawn.
2. Maximum  $\frac{\partial}{\partial V_g} \sqrt{I_d}$  is found, and marker is moved to corresponding point on  $\sqrt{I_d}$  curve.
3. Tangent is drawn to marker on  $\sqrt{I_d}$  curve.
4. X intercept value of this tangent is  $V_{th}$ .

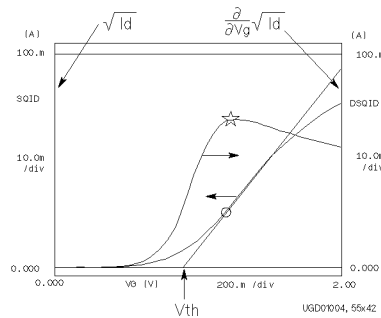

Introducing the HP 4155A/4156A

## **An Overview of Functions**

---

### Data Storage

The HP 4155A/4156A can store data on a 3.5-inch diskette. You can store the measurement setup information, measurement data, and HP 4155A/4156A system setup information on the diskette. You can also easily save measurement result data in MS-DOS® ASCII format to your diskette by using print/plot function. (For details, see “To Store Result Data in Spreadsheet Format” in Chapter 5.)

Also, you can load information from the diskette to the HP 4155A/4156A.

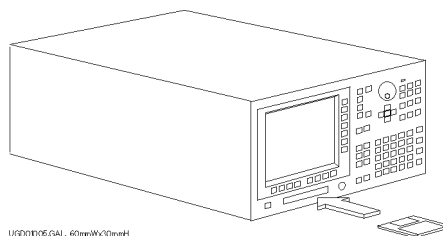

The allowable disk formats are MS-DOS® and HP LIF. The MS-DOS® format is the most popular disk format, which allows you to use the diskette in many types of computers.

The HP 4155A/4156A is upwardly compatible with the HP 4145B, so you can load setting information that was created by the HP 4145B.

You can also use internal memory for temporary data storage. You can save up to four files in internal memory. You can quickly move information between the internal memory and HP 4155A/4156A working memory.

---

## Plotting and Printing

You can print setup data, measurement results, and screen images on a plotter or printer that is connected to the HP 4155A/4156A. Setup data and list results are printed as a list report, and the graphics results page is plotted as a graphics report. You can also plot or print the screen image.

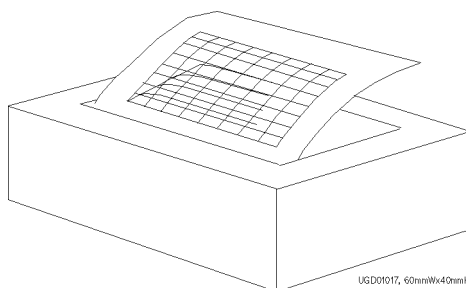

You can connect your plotter or printer to the HP 4155A/4156A via serial interface or HP-IB interface. See Chapter 2 for information about installing your plotter or printer.

Also, you can store setup data, measurement results, and screen images on diskette files. The stored data files can be read by other computers.

So you can create reports that include measurement curves or data by using spreadsheet software such as Lotus® 1-2-3® or by using desktop publishing software such as PageMaker™. For details about saving data in MS-DOS® ASCII format, refer to “To Store Result Data in Spreadsheet Format” in Chapter 5.

Introducing the HP 4155A/4156A  
**An Overview of Functions**



**Installation**



---

# Installation

This chapter describes requirements to install HP 4155A/4156A and the tasks for installation, and is organized into the following four sections:

- Requirements
- Setting up HP 4155A/4156A
- Installing Accessories



---

## WARNING

The HP 4155A/4156A can force dangerous voltages (200 V for HPSMU, and 100 V for HRSMU and MPSMU) at the force, guard, and sense terminals. To prevent electric shock hazard, the following safety precautions must be observed during the use of the HP 4155A/4156A.

- Use a three-conductor ac power cable to connect cabinet (if used) and HP 4155A/4156A to an electric ground (safety ground).
  - If you do not use HP 16442A Test Fixture, make sure to connect the INTLK terminal to a switch that turns off when the shielding box access door is opened.
  - Confirm periodically that INTLK function works normally.
  - Before touching the connections of the force, guard, and sense terminals, turn the HP 4155A/4156A off and discharge any capacitors whenever possible. If you do not turn the HP 4155A/4156A off, complete *all* of the following items, regardless of any HP 4155A/4156A settings.
    - Set the SMU output switches to off.
    - Confirm that HIGH VOLTAGE indicator is not lit.
    - Open the shielding box access door (open the INTLK terminal).
    - Discharge any capacitors if the capacitance is connected to an SMU.
  - Warn workers around the HP 4155A/4156A about dangerous conditions.
-

---

# Requirements

This section describes the following requirements

- Power requirements
- Power cable
- Ventilation requirements
- Operating environment

Installation  
**Requirements**

---

## Power Requirements

---

**CAUTION**

---

Before applying ac line power to the HP 4155A/4156A or HP 41501A, ensure that the correct line fuse is installed in the fuse holder and the correct power cable is used.

Line	Line Voltage Fuse	
	Fuse Type	HP Part Number
100/120 Vac	UL/CSA T 8A, 250 Vac	2110-0383
220/240 Vac	UL/CSA T 4A, 250 Vac	2110-0014

---

**CAUTION**

---

Use only replacement fuses of the correct current rating and of the specified type. Do not use repaired fuses, and do not short circuit the fuse holder.

The HP 4155A/4156A can operate from any single-phase ac power source supplying 100 - 120 V or 220 - 240 V in the frequency range from 50 to 60 Hz. The maximum power consumption is 600 VA for HP 4155A/4156A, and 450 VA for HP 41501A. For details, see "Specifications" in *HP 4155A/4156A User's Dictionary Reference*.

The line voltage selector switch is set at the factory for your area. But, you had better check the voltage selector setting before applying ac line power to the HP 4155A/4156A or HP 41501A. The line voltage selector switch is located on the rear panel of the HP 4155A/4156A and HP 41501A.

Line Voltage Selector setting	
Line Voltage	Position
90-132 Vac	left
198-264 Vac	right

## Power Cable

In accordance with international safety standards, this instrument is equipped with a three-wire power cable. When connected to an appropriate ac power outlet, this cable grounds the instrument frame. The type of power cable shipped with each instrument depends on the country of destination. Refer to Figure 2-1 for the part numbers of the power cables available.

	
<ul style="list-style-type: none"> <li>● Plug: BS 1363A, 250 V</li> <li>● Cable: HP 8120-1351</li> </ul>	<ul style="list-style-type: none"> <li>● Plug: NZSS 198/AS C112, 250 V</li> <li>● Cable: HP 8120-1369</li> </ul>
	
<ul style="list-style-type: none"> <li>● Plug: CEE-VII, 250 V</li> <li>● Cable: HP 8120-1689</li> </ul>	<ul style="list-style-type: none"> <li>● Plug: NEMA 5-15P, 125 V, 15 A</li> <li>● Cable: HP 8120-1378</li> </ul>
	
<ul style="list-style-type: none"> <li>● Plug: NEMA 6-15P, 250 V, 15 A</li> <li>● Cable: HP 8120-0698</li> </ul>	<ul style="list-style-type: none"> <li>● Plug: SEV 1011.1959-24507 Type 12, 250 V</li> <li>● Cable: HP 8120-2104</li> </ul>

Figure 2.1. Power Cables

Installation  
**Requirements**

	
<ul style="list-style-type: none"> <li>● Plug: DHCR 107, 220 V</li> <li>● Cable: HP 8120-2956</li> </ul>	<ul style="list-style-type: none"> <li>● Plug: SABS 164, 250 V</li> <li>● Cable: HP 8120-4211</li> </ul>
	
<ul style="list-style-type: none"> <li>● Plug: JIS C 8303, 125 V, 15 A</li> <li>● Cable: HP 8120-4753</li> </ul>	

**Power Cables (continued)**

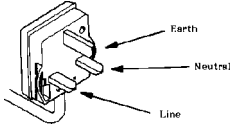
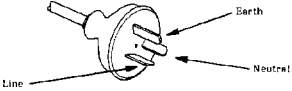
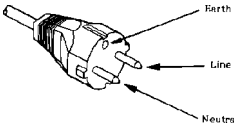
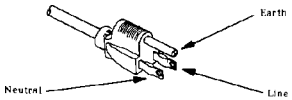
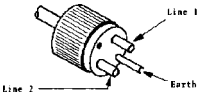
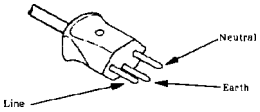
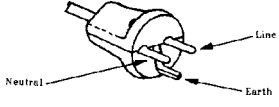
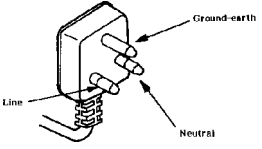
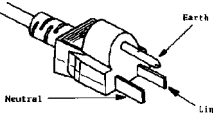
If the plug on the cable does not fit the power outlet, or the cable is to be attached to a terminal block, cut the cable at the plug end and re-wire it. This work should be performed by a qualified electrician—all local electrical codes being strictly observed.

The color coding used in the cable will depend on the cable supplied. If a new plug is to be connected, it must meet local safety requirements and include the following features:

- Adequate load-carrying capacity (see table of “Specifications” in *HP 4155A/4156A User’s Dictionary Reference*).
- Ground connection.
- Cable clamp.

**WARNING**

For protection from electrical shock, the power cable ground must not be defeated.

---

## Ventilation Requirements

The HP 4155A/4156A has one cooling fan, and HP 41501A has two cooling fans. To ensure adequate airflow, make sure that there is adequate clearance around the cooling fans: 6 inches (150 mm) behind, 3 inches (70 mm) sides, and 0.5 inch (12 mm) above and below.

If the airflow is restricted, the internal operating temperature will be higher, reducing the instrument's reliability or causing the instrument's thermal-protection circuits to automatically switch off the instrument.

---

## Operating Environment

The HP 4155A/4156A and HP 41501A must be operated within the following environmental conditions:

Temperature: 5°C to 40°C (41°F to 104°F)

Humidity: 15% to 80% RH at 40°C (104°F)

---

## Cleaning

To prevent electrical shock, never use a wet cloth when cleaning the HP 4155A/4156A. Always use a slightly damp or dry cloth to clean HP 4155A/4156A.

---

## Setting up HP 4155A/4156A

This section describes what you do when you receive the HP 4155A/4156A and accessories.

Briefly, you must do the following:

1. Inspect HP 4155A/4156A and accessories.
2. Install HP 41501A with HP 4155A/4156A, if needed.
3. Check HP 4155A/4156A operation after supplying ac line power.

To satisfy the specifications of HP 4155A/4156A and HP 41501A measurement accuracy, perform calibration and adjustment every year.

---

## To Inspect HP 4155A/4156A and Accessories

Inspect the following items when the HP 4155A/4156A and accessories arrive at your site, and when you open the boxes that contain the HP 4155A/4156A and accessories:

- When the HP 4155A/4156A and accessories arrive at your site, and before unpacking any components, inspect all boxes for any signs of damage that might have occurred during shipment such as:
  - Dents
  - Scratches
  - Cuts
  - Water marks

If you suspect damage, notify your local HP sales office.

- When you open the boxes that contain the HP 4155A/4156A and accessories, check the components against the contents lists that are attached to the boxes.

If anything is missing, notify your local HP sales office.

## To Install HP 41501A SMU/Pulse Generator Expander

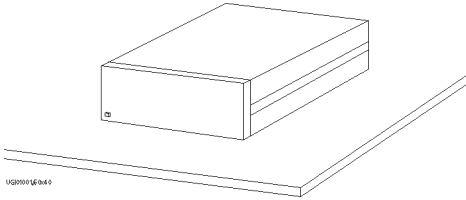
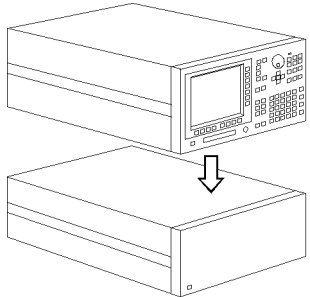
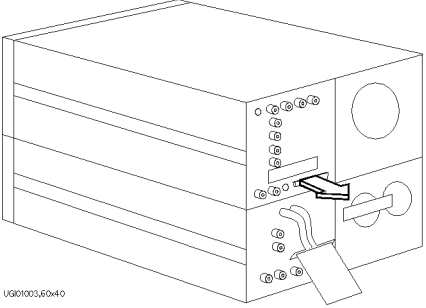
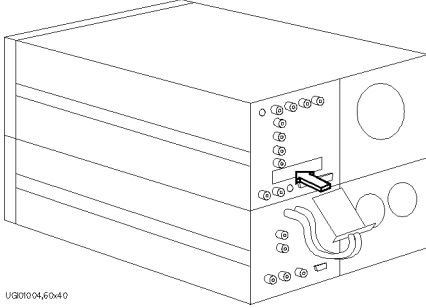
1. Put the HP 41501A on your workbench.	2. Put the HP 4155A/4156A on the HP 41501A.
 <p>UG010156-04-0</p>	 <p>UG010256-04-0</p>
3. Remove the blank panel labeled "To Expander Box Interface" from the rear panel of the HP 4155A/4156A.	4. Insert the interface board from the HP 41501A into the HP 4155A/4156A, then attach it with the thumbscrews.
 <p>UG010156-04-0</p>	 <p>UG010156-04-0</p>

**WARNING**

The HP 4155A/4156A together with the HP 41501A weighs about 40 kg (88.4 lb). The HP 4155A/4156A is just placed on top of the HP 41501A without attaching it securely. So, be very careful when handling.



## To Check HP 4155A/4156A Operation

1. Make sure that the line switches are set to off.
2. On the HP 4155A/4156A, make sure that the **Circuit Common** terminal is tied to frame ground terminal by shorting-bar. If not, a potential shock hazard exists.
3. Connect the power cable between the HP 4155A/4156A and outlet at your site. If the HP 41501A is also installed, connect the power cable between the HP 41501A and the outlet.
4. If the HP 41501A is installed, press the **LINE** button to switch on.
5. Press the **LINE** button to switch on the HP 4155A/4156A. The initialization screen appears on the CRT of the HP 4155A/4156A.
6. After initialization finishes, the **CHANNELS: CHANNEL DEFINITION** page appears as follows:

CHANNELS: CHANNEL DEFINITION 94 JAN01 01:30PM

SWEEP

\*MEASUREMENT MODE  
SWEEP

*CHANNELS		MEASURE				STBY	SERIES
UNIT	VNAME	INAME	MODE	FCTN		RESISTANCE	
SMU1:MP	V1	I1	COMMON	CONST		0 ohm	
SMU2:MP	V2	I2	I	VAR2		0 ohm	
SMU3:MP	V3	I3	V	VAR1			
SMU4:MP	V4	I4	V	CONST			
VSU1	VSU1	-----	V	CONST			
VSU2	VSU2	-----	V	CONST			
VMU1	VMU1	-----	V	-----	----		
VMU2	VMU2	-----	V	-----	----		

SAM-PLING  
  
 DEFAULT MEASURE SETUP  
 MEM1 M B-Tr VCE-IC  
 MEM2 M FET VGS-ID  
 MEM3 M FET VGS-ID  
 MEM4 M DIODE VF-IF

SWEEP

CHANNEL DEF	USER FCTN	USER VAR		B		NEXT PAGE
-------------	-----------	----------	--	---	--	-----------

327095,32610

7. Make sure the units displayed in the **UNIT** column (on the **CHANNELS: CHANNEL DEFINITION** page) match the units that are actually installed.

The following table shows the displayed units in the **UNIT** column:

HP 4155A	HP 4156A	HP 41501A		
SMU1:MP	SMU1:HR	GNDU		
SMU2:MP	SMU2:HR	HPSMU Installed <sup>1</sup>	MPSMU Installed <sup>1</sup>	PGU Installed <sup>1</sup>
SMU3:MP	SMU3:HR			
SMU4:MP	SMU4:HR	SMU5:HP	SMU5:MP SMU6:MP	PGU1 PGU2
VSU1	VSU1			
VSU2	VSU2			
VMU1	VMU1			
VMU2	VMU2			

<sup>1</sup> These are labeled on the rear panel of the HP 41501A.

8. If HP 41501A units are not displayed in UNIT column, turn off the HP 4155A/56A and HP 41501A, then make sure that interface board of HP 41501A is firmly inserted into HP 4155A/56A. Turn on HP 41501A, then turn on HP 4155A/56A.
9. Press **(System)** front-panel key, then select **MISCELLANEOUS** primary softkey. Confirm that POWER LINE FREQUENCY field is correct frequency for your site. If not, select the correct secondary softkey.

SYSTEM: MISCELLANEOUS 94JAN01 01:30PM 50 Hz

\*HP4155 is  
 NOT SYSTEM CONTROLLER

\*POWER LINE FREQUENCY  
 50Hz  60 Hz

\*HP-IB ADDRESS  
 HP 4155 17  
 HARD COPY 1

\*SERIAL INTERFACE  
 BAUD RATE 2400 bps  
 DATA BITS 8  
 PARITY None  
 STOP BIT(S) 1  
 TRANSMIT PACING HARDWARE  
 RECEIVE PACING None

\*REMOTE CONTROL  
 COMMAND SET HP4155/56

\*CLOCK  
 Y M D H M  
 1994 1 1 13 28

\*BEEP  
 ON

FILTER MISCELLANEOUS CONFIG CALIB/DIAG PRINT COLOR  
 LANEIOUS LANEIOUS SETUP SETUP

If problems occur, see Chapter 6.

---

## Installing Accessories

This section describes how to install the HP 4155A/4156A and accessories at your site. Refer to “Ventilation Requirements” when considering the proper location at which to install the HP 4155A/4156A.

This section describes how:

- To install connector plate
- To connect interlock terminal
- To install HP 16442A Test Fixture
- To install HP 16441A R-Box
- To install HP 16440A SMU/Pulse Generator Selector
- To connect HP 16440A to HP 4155A/4156A

When you install a keyboard (HP C1405B), connect the connector of the keyboard to the keyboard interface on the front-panel *before* switching on the HP 4155A/4156A. The HP 4155A/4156A recognizes the keyboard during the power-on self-test.

---

## To Install Connector Plate

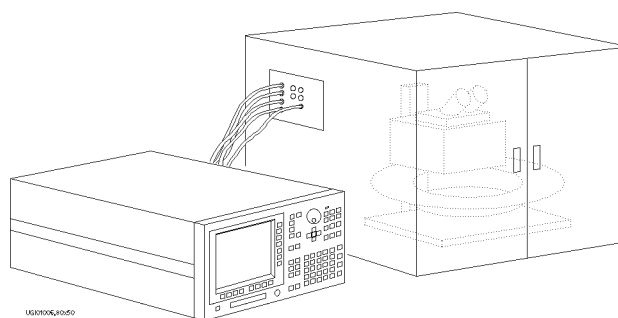

1. Before installing connector plate, make sure that HP 4155A/4156A and HP 41501A are turned off.
2. Create proper openings and screw holes on your shielding box that match the size of connector plate. See Figure 2-2, Figure 2-3, or Figure 2-4 for dimensions of the connector plates.
3. Attach the connector plates with screws, nuts, and washers.
4. To prevent electric shock, make sure to install interlock circuit. (See “To Connect Interlock Terminal”.)
5. Connect the furnished cables between the HP 4155A/4156A and connector plates.

For details about connections between HP 4155A/4156A and the terminals on the connector plates, refer to “To Install HP 16442A Test Fixture” in this chapter. Connections to connector plate are similar to connections to test fixture.

The proper connector plates are furnished with HP 4155A, HP 4156A, and HP 41501A.

The screws, nuts, and washers are not furnished. Each connector plate has four screw holes (3.0 mm in diameter).

Installation

**Installing Accessories**

If you do not use the HP 16442 test fixture (for example, you use a wafer prober or your own test fixture), you need to perform measurements in a shielding box because of the following:

- To prevent the operator from receiving an electric shock from the output voltage or current of the HP 4155A/4156A.
- To minimize the effects of environmental noise and ambient light.

For details on how to connect terminals of connector plate and DUTs, refer to “Connection to Device Under Test (DUT)” in Chapter 3.

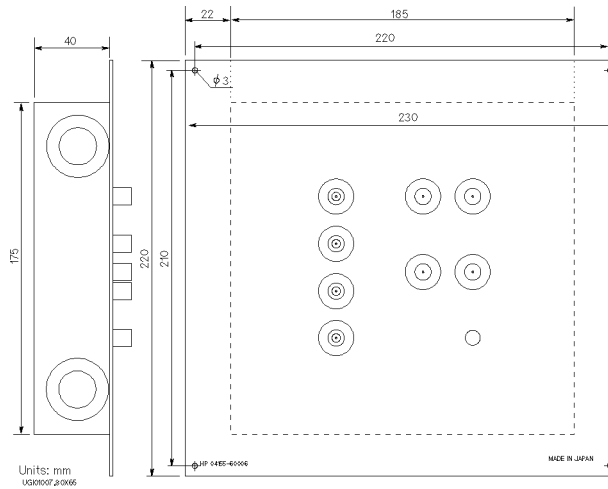

**Figure 2.2.**  
**Dimensions of Connector Plate for HP 4155A**  
**(HP Part Number: 04155-60006)**

**Table 2-1. Connectors on Connector Plate**

Connector	HP Part Number
Triaxial for SMU, GNDU	1250-1906
Coaxial (BNC) for VSU, VMU, PGU	1250-0083
Interlock	1252-1419

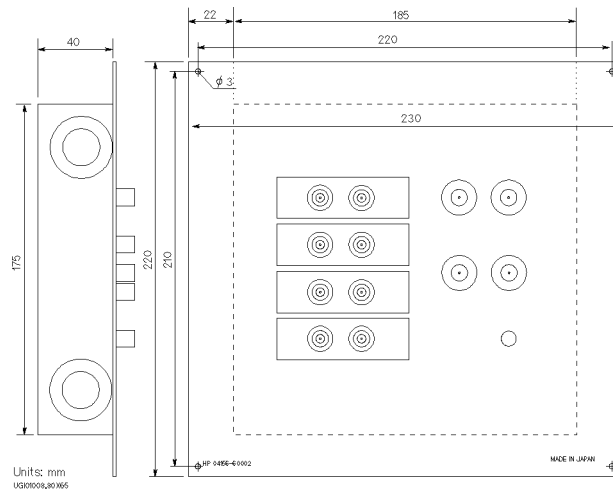

**Figure 2-3.**  
**Dimensions of Connector Plate for HP 4156A**  
**(HP Part Number: 04156-6002)**

Installation  
**Installing Accessories**

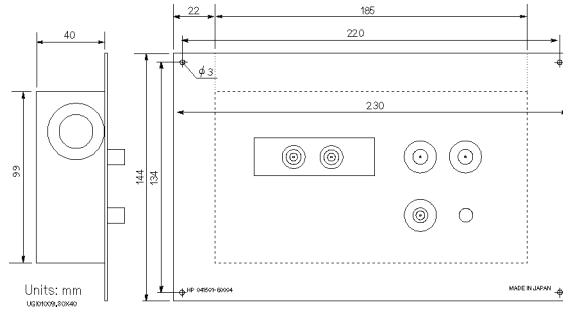
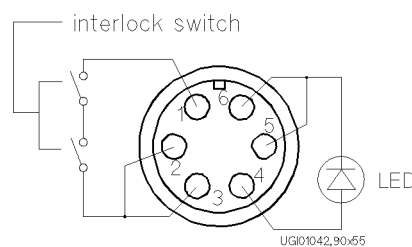
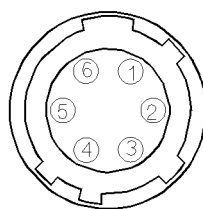
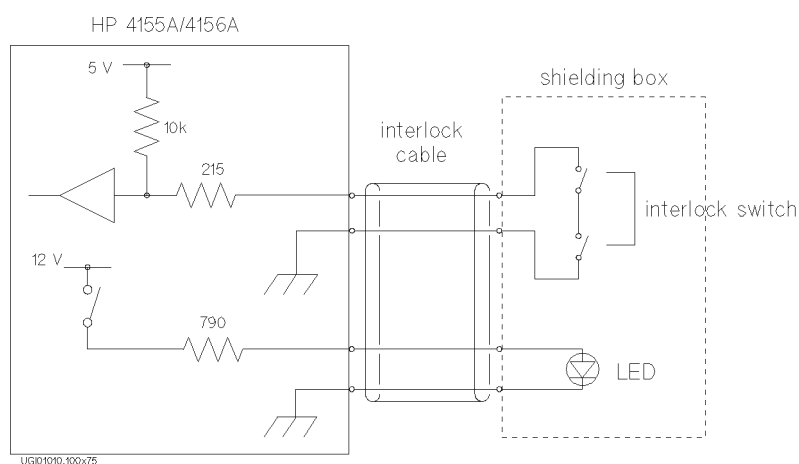

**Figure 2.4.**  
**Dimensions of Connector Plate for HP 41501A**  
**(HP Part Number: 41501-60004)**

## To Connect Interlock Terminal

When you use a shielding box, you must install an interlock circuit to prevent electric shock. When you use the HP 16442A test fixture, you do *not* have to install an interlock circuit because the HP 16442A has a built-in interlock circuit.

The upper part of the following shows the interlock circuit you need to make in your shielding box, and the lower part shows the pin assignments of the interlock connector on the connector plate.



(a) plug side view of Intlk terminal (b) wiring side view of Intlk terminal



**interlock (Intlk) terminal.**

To prevent an operator from receiving an electric shock from high voltage (more than  $\pm 40$  V), you connect the interlock (Intlk) terminal (of the connector plate) to a switch that turns on when the shielding box door is closed, and that turns off when the shielding box access door is opened. For safety, use two switches in series.

If the door is open (the interlock terminals are open), the SMU cannot force more than  $\pm 40$  V. If the door is opened while the SMU output is more than  $\pm 40$  V, the HP 4155A/4156A immediately drops the outputs of all units to 0 V.

Conversely, if the door is closed (interlock terminals are shorted), this function is disabled. So, you can force more than  $\pm 40$  V.

**WARNING**

Dangerous voltages of up to the maximum voltage of SMUs may be present at force, guard, and sense terminals when the interlock terminals are shorted.

**HP 16435A Interlock Cable Adapter.**

If you already have a connector plate or test fixture that has a BNC coaxial connector for interlock (such as the HP 16088B test fixture), you can use HP 16435A Interlock Cable Adapter to connect the test fixture.

To connect:

1. Connect interlock (Intlk) terminal on the rear panel of the HP 4155A/4156A to the interlock cable adapter by using the following interlock cable.

HP Part Number	Description
04155-61613	Interlock cable 3 m
04155-61614	Interlock cable 1.5 m

2. Connect the interlock cable adapter to the connector plate or test fixture by using the coaxial cable furnished with HP 16435A.

**Warning Indicator on HP 16088B Test Fixture**

The high voltage warning indicator on this test fixture is designed only for HP 41423A High Voltage Source/Monitor Unit for HP 4142B.

This warning indicator is not valid when you use the HP 16088B test fixture with the HP 4155A/4156A by using HP 16435A interlock cable adapter.

**LED terminal.**

When more than  $\pm 40$  V is forced from an SMU, the LED lights to indicate *high voltage output*.

**recommended parts.**

You can get the following parts from Hewlett-Packard:

HP Part Number	Description
3101-3241	switch
3101-0302	switch
1450-0641	LED $ V_F \approx 2.1 \text{ V} @ I_F = 10 \text{ mA} $

Installation  
**Installing Accessories**

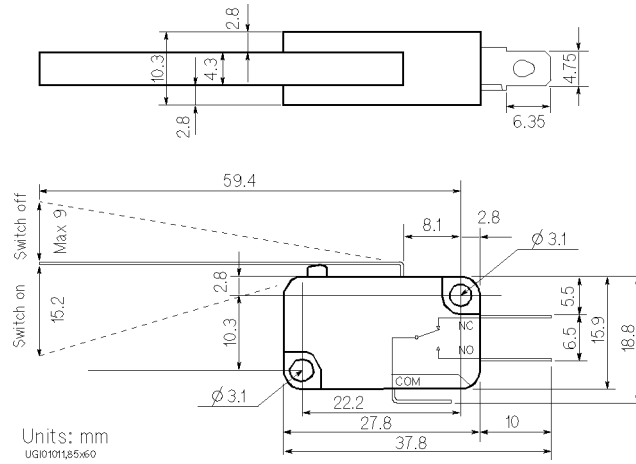

**Figure 2-5. Dimensions of Interlock Switch (HP part number 3101-0302)**

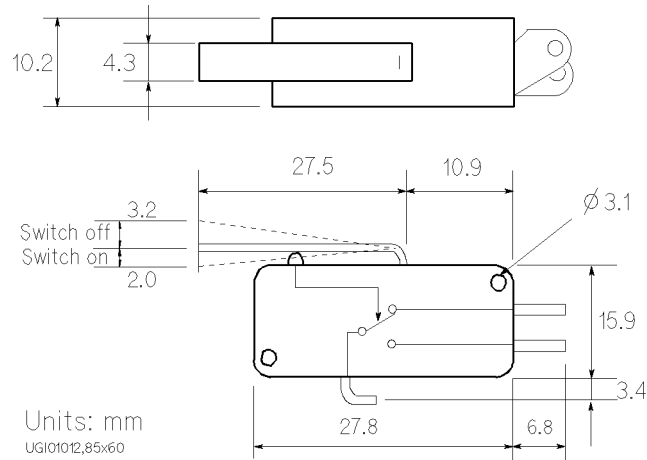

**Figure 2-6. Dimensions of Interlock Switch (HP part number 3101-3241)**

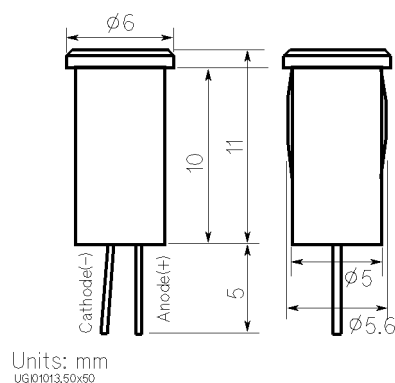

Figure 2-7. Dimensions of LED (HP part number 1450-0641)

#### To Perform Interlock Circuit Test

To confirm that interlock circuit test, do as follows:

1. Connect the **Intlk** terminal of HP 4155A/4156A to your interlock circuit.
2. Press **(System)** front-panel key, then select **CALIB/DIAG** primary softkey to display the SYSTEM: SELF-CALIBRATION/DIAGNOSTICS page.
3. In the CALIB/DIAG field, select **DIAG** secondary softkey.
4. In the CATEGORY field, select **I/O & PERIPH** secondary softkey.
5. Move pointer to the **403 (INT.) Interlock & LED** field.
6. Select **EXECUTE** secondary softkey.
7. Confirm the following:
  - LED turns on within 1 sec from when interlock circuit is shorted.
  - LED turns off within 1 sec from when interlock circuit is open.
8. To stop the interlock test, select **STOP** secondary softkey.

---

## To Connect Connector Plate and DUT

- GNDU connections

---

### CAUTION

Do not use the HP 16493C triaxial cable of the SMU to connect the GNDU to a DUT. The GNDU can sink up to 1.6 A, and the maximum current rating of the cable is 1 A.

- Kelvin connections

Use a low-noise coaxial cable (part number: 8120-3674) from the connector plate to DUT as shown in the following figure. To cancel the effects of cable resistance, connect the sense line as close as possible to the terminal of the DUT.

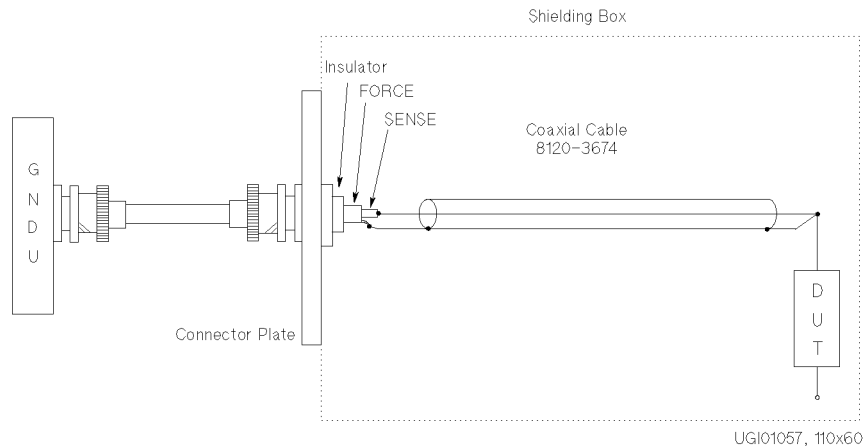

□ non-Kelvin connections

Short sense and force at the connector plate as shown. Use AWG 22 single-strand insulated wire (part number: 8150-2639) from the connector plate to the DUT. Measurement results include the residual resistance of the connection wire.

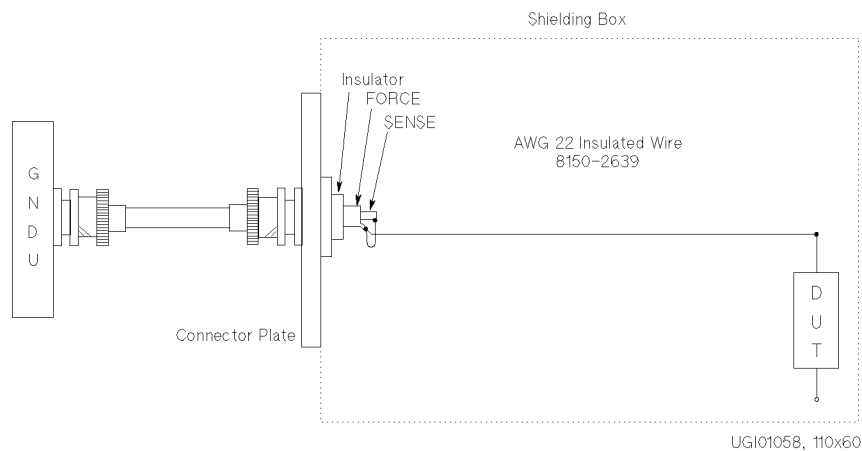

To easily connect GNDU for a measurement in which the accuracy is not important, connect only force to the DUT, without shorting sense and force.

Installation  
**Installing Accessories**

- SMU connections

**WARNING**

The SMU forces dangerous voltages of up to  $\pm 100$  V ( $\pm 200$  V for HPSMU) at the force, sense, and guard terminals.

To prevent electric shock, do not expose these lines.

Before turning the HP 4155A/4156A on, connect the Intlk terminal to a switch that turns off when the shielding box access door is opened.

Before you touch connections of these terminals, turn HP 4155A/56A off, disconnect power cable, and discharge any capacitors.

**CAUTION**

Never connect the guard terminal to any output, including circuit common, chassis ground, or the guard terminal of any other unit. Doing so may result in an emergency condition.

- Kelvin connections

Use low-noise coaxial cable (part number: 8120-4461) from connector plate to DUT as shown in following figure. To cancel effects of cable resistance, connect sense line as close as possible to DUT terminal. To prevent oscillations, do not use cables longer than 1.5 m. For highly accurate current forcing and measurements while minimizing leakage, surround all force and sense lines from SMU by a guard as far as possible, and make cables stable by taping.

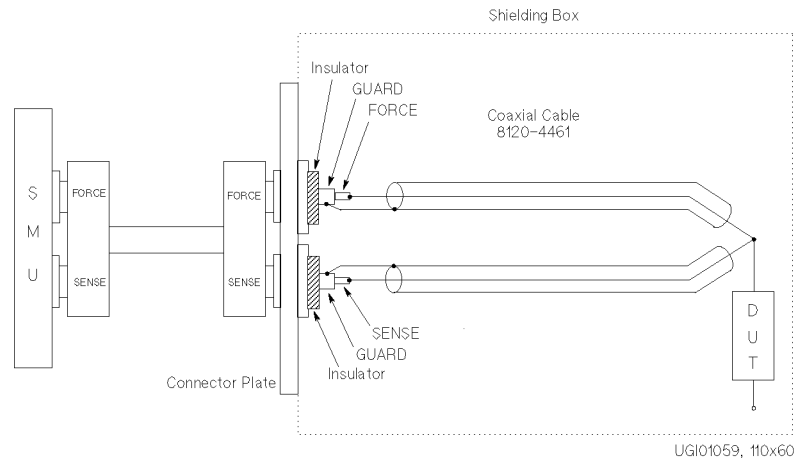

□ non-Kelvin connections

Connections are shown in following figure. Measurement results include residual resistance from the connection wire. To enable highly accurate current forcing and measurements while minimizing leakage, surround all force lines from SMU by a guard as far as possible.

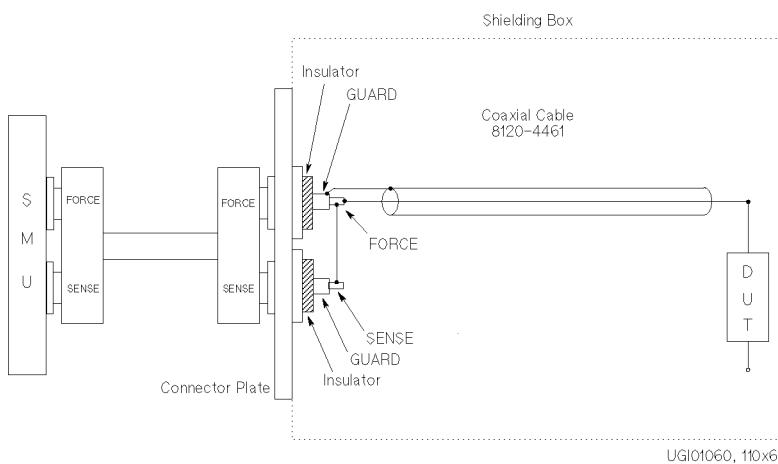



Installation

**Installing Accessories**

**NOTE**

When you make a connection by using low-noise coaxial cable (part number: 8120-4461), shave the Conductive layer and the Insulator(clear) by knife so that the Center Conductor is insulated from the Conductive layer. Refer to following figure.

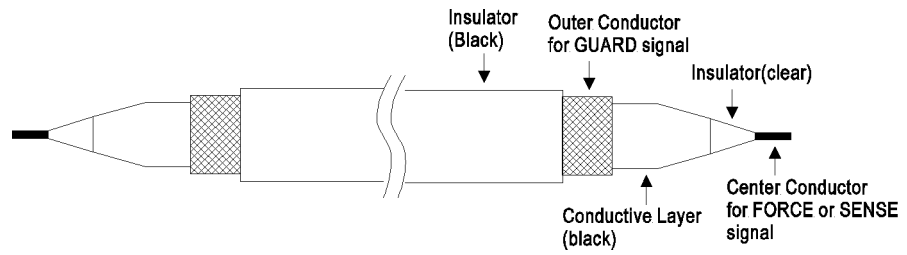

- VSU and VMU connections

The following figure shows an example of a connection between VSU1, VSU2, VMU1, or VMU2 and a DUT. Use AWG 24 single-strand insulated wire (part number: 8150-0447) to connect the connector plate and the DUT.

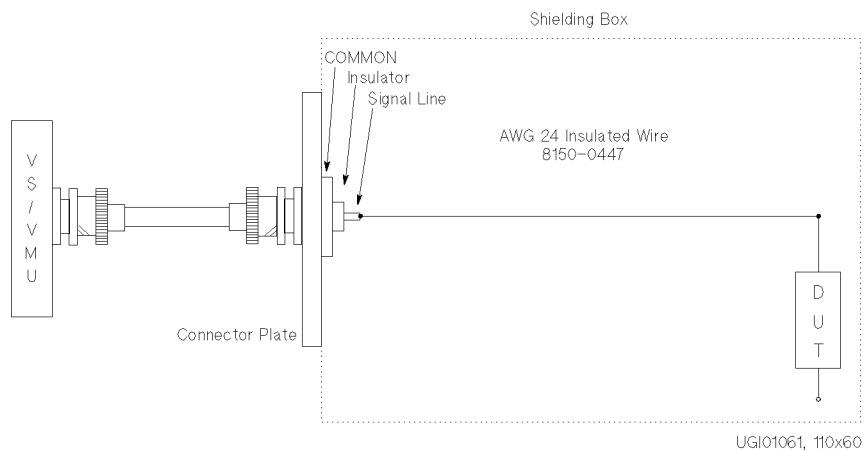

**Installing Accessories**

- PGU connections

Regardless of output impedance setting, use a low-noise coaxial cable (part number: 8120-0102) from the connector plate to the DUT as shown in the following figure. If you use HP 16440A selector, use a low-noise coaxial cable (part number: 8120-4461).

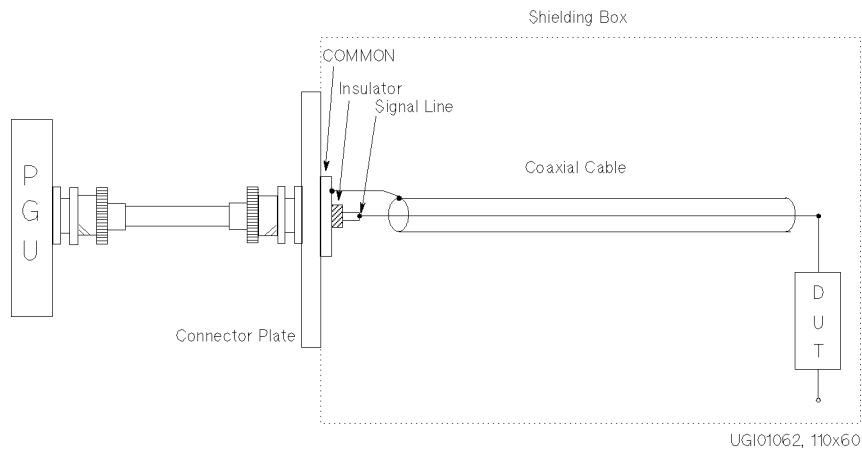

---

## To Install HP 16442A Test Fixture

Before performing the following procedure, make sure that HP 4155A/4156A and HP 41501A are turned off.

When you use HP 16442A test fixture without HP 16441A R-Box or HP 16440A selector, you can make HP 16442A stable by using stabilizers as shown in the following figure.

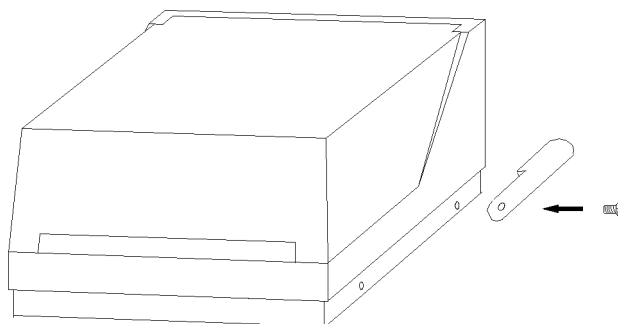

UGI01049.GAL 80mmW, 60mmH

1. Put a stabilizer on both sides of test fixture.
2. Screw a flathead screw into hole of each stabilizer.

Installation  
**Installing Accessories**

- Connecting HP 4155A and HP 16442A test fixture

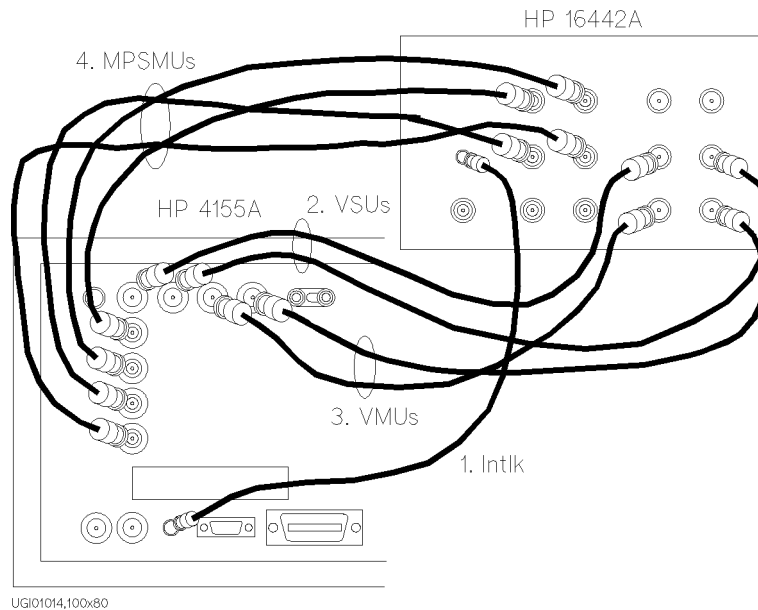

1. To prevent shock, *be sure* to connect following by 3.0m or 1.5m Intlk cable: Intlk terminal (HP 4155A)  $\iff$  Intlk terminal (HP 16442A)
2. Connect the following by using 3.0 m or 1.5 m coaxial cables:  
VSU terminals (HP 4155A)  $\iff$  VSU terminals (HP 16442A)
3. Connect the following by using 3.0 m or 1.5 m coaxial cables:  
VMU terminals (HP 4155A)  $\iff$  VMU terminals (HP 16442A)
4. Connect the following by using 3.0 m or 1.5 m triaxial cables:  
MPSMU terminals (HP 4155A)  $\iff$  SMU terminals (HP 16442A)

---

**WARNING**

MPSMUs force dangerous voltage of up to  $\pm 100$  V at the Force, Sense, and Guard terminals. To prevent electric shock, do not expose these lines.

---

**CAUTION**

Never connect Guard terminal to any output, including circuit common, frame ground, or other guard terminal. Doing so will damage SMU.

- Connecting HP 4156A and HP 16442A test fixture

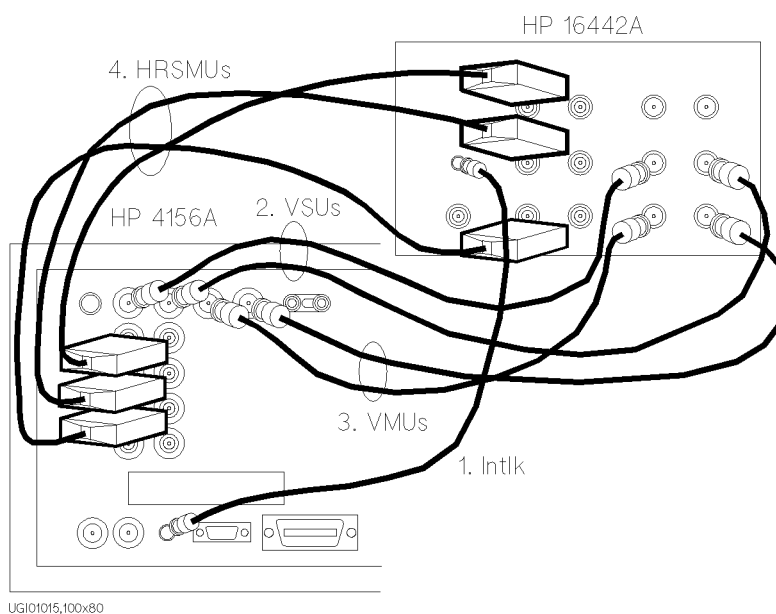

1. To prevent shock, *be sure* to connect following by 3.0m or 1.5m Intlk cable: Intlk terminal (HP 4156A)  $\iff$  Intlk terminal (HP 16442A)
2. Connect the following by using 3.0 m or 1.5 m coaxial cables:  
VSU terminals (HP 4156A)  $\iff$  VSU terminals (HP 16442A)
3. Connect the following by using 3.0 m or 1.5 m coaxial cables:  
VMU terminals (HP 4156A)  $\iff$  VMU terminals (HP 16442A)
4. Connect the following by using 3.0 m or 1.5 m Kelvin triaxial cables:  
HRSMU terminals (HP 4156A)  $\iff$  SMU terminals (HP 16442A)

**WARNING**

HRSMUs force dangerous voltage of up to  $\pm 100$  V at the Force, Sense, and Guard terminals. To prevent electric shock, do not expose these lines.

**CAUTION**

Never connect guard terminal to any output, including circuit common, chassis ground, or other guard terminal. Doing so will damage SMU.

Installation  
**Installing Accessories**

- Connecting HP 41501A and HP 16442A test fixture

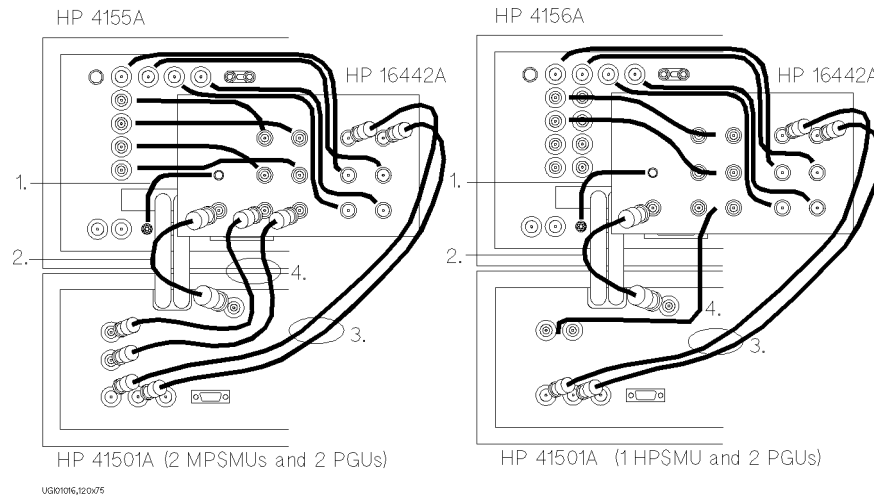

1. To prevent electric shock, make sure that Intlk terminal of HP 4155A/4156A is connected to Intlk terminal of HP 16442A.
2. Connect the following by using a 3.0 m or 1.5 m GNDU cable:  
GNDU terminal (HP 41501A)  $\iff$  GNDU terminal (HP 16442A)
3. If the HP 41501A is equipped with two PGUs, connect the following by using 3.0 m or 1.5 m coaxial cables:  
PGU terminals (HP 41501A)  $\iff$  PGU terminals (HP 16442A)
4. Do the following:
  - If the HP 41501A is equipped with two MPSMUs, connect the following by using 3.0 m or 1.5 m triaxial cables:  
MPSMU terminals (HP 41501A)  $\iff$  SMU terminals (HP 16442A)
  - If the HP 41501A is equipped with HPSMU, connect the following by using 3.0 m or 1.5 m Kelvin triaxial cable:  
HPSMU terminal (HP 41501A)  $\iff$  SMU terminal (HP 16442A)

**WARNING**

Do not use the HP 16493C triaxial cable for SMUs to connect GNDU to a test fixture or a connector plate. The GNDU cable can sink up to 1.6 A, but the maximum current rating of the HP 16493C is 1 A.

**WARNING**

HPSMU forces dangerous voltage of up to  $\pm 200$  V at the Force, Sense, and Guard terminals. To prevent electric shock, do not expose these lines.

**CAUTION**

Never connect the Guard terminal to any output, including circuit common, chassis ground, or other guard terminal. Doing so will damage SMU damage.

**Installing HP 16442A test fixture with other accessories.**

The HP 16442A test fixture can be installed with an HP 16441A R-box, HP 16440A selector, or both. The following figure shows how to attach the HP 16442A to other accessories.

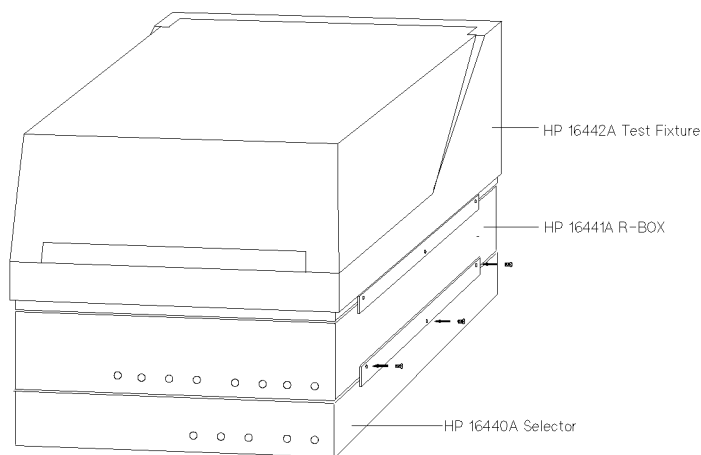

UG01046, 90mmWx90mmH



**Installing HP 16088B Test Fixture**

You can easily install HP 16088B test fixture by using HP 16434A Kelvin Triaxial Cable and HP 16435A Interlock Cable Adapter.

To install HP 16088B:

1. Connect the following by using:
  - 3.0m or 1.5 m kelvin triaxial cables (When connecting HP 4156A or HPSMU of HP 41501A):  
**HRSMU** or **HPSMU** terminals (HP 4156A/HP 41501A)  $\iff$  **SMU** terminals (HP 16088B)
  - 3.0 m or 1.5 m triaxial cables (When connecting HP 4155A or MPSMUs of HP 41501A):  
**MPSMU** terminals (HP 4155A/HP 41501A)  $\iff$  **SMU** terminals (HP 16088B)
2. To prevent electric shock, *be sure* to connect **Intlk** terminal (HP 4155A/4156A) and **INTLK** terminal (HP 16088B) as follows:
  - a. Connect the following by using 3.0 m or 1.5 m Intlk cable furnished with HP 4155A/4156A:  
**Intlk** terminal (HP 4155A/4156A)  $\iff$  16435-61001 INTLK CABLE ADAPTER
  - b. Connect the following by using coaxial cable furnished with HP 16435A:  
16435-61001 INTLK CABLE ADAPTER  $\iff$  **INTLK** terminal (HP 16088B)

For more information about the HP 16435A interlock cable adapter and the HP 16088B test fixture, see “To Connect Interlock Terminal” in this chapter.

## To Install HP 16441A R-Box

Before installing HP 16441A R-Box, make sure that HP 4155A/4156A and HP 41501A are turned off.

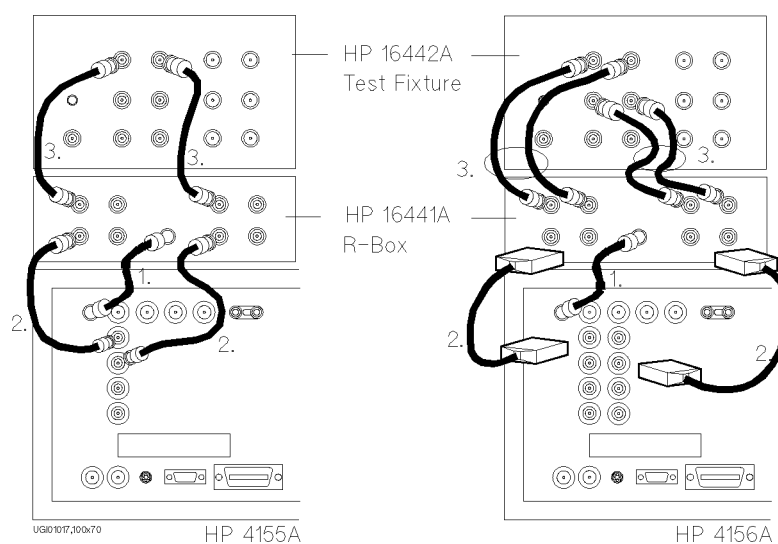

1. Connect the following by using a 3.0 m or 1.5 m control cable:  
 To R-Box terminal (HP 4155A/4156A)  $\iff$  Control terminal (HP 16441A)
2. Connect the following by using:
  - 3.0 m or 1.5 m triaxial cables (when connecting HP 4155A or MPSMUs of HP 41501A):  
 MPSMU terminals (HP 4155A/HP 41501A)  $\iff$  Input Force terminals (HP 16441A)
  - 3.0 m or 1.5 m Kelvin triaxial cables (when connecting HP 4156A or HPSMU of HP 41501A):  
 HRSMU or HPSMU terminals (HP 4156A/HP 41501A)  $\iff$  Input terminals (HP 16441A)

**Installing Accessories**

3. Connect the following by using:

- 40 cm triaxial cables (when connecting HP 4155A or MPSMUs of HP 41501A):  
Output Force terminals (HP 16441A)  $\iff$  SMU terminals (HP 16442A or connector plate)
- 40 cm triaxial cables (when connecting HP 4156A or HPSMU of HP 41501A):  
Output Force terminals (HP 16441A)  $\iff$  SMU terminals (HP 16442A or connector plate)  
Output Sense terminals (HP 16441A)  $\iff$  SMU terminals (HP 16442A or connector plate)

**Installing HP 16441A R-box with other accessories.**

You can attach the HP 16441A R-box to the HP 16442A test fixture or to your shielding box. The following figures show how to attach the HP 16441A R-box.

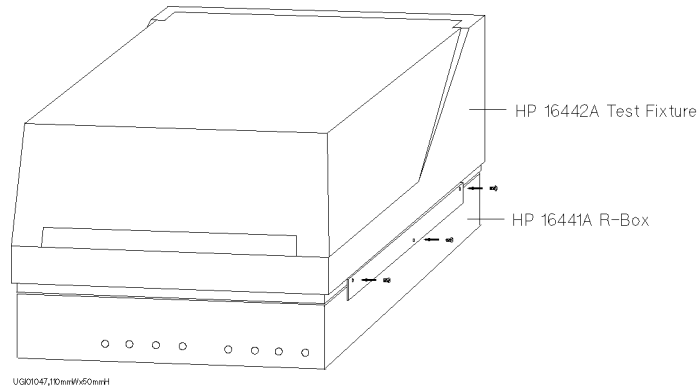

**Attaching HP 16441A R-Box to HP 16442A Test Fixture**

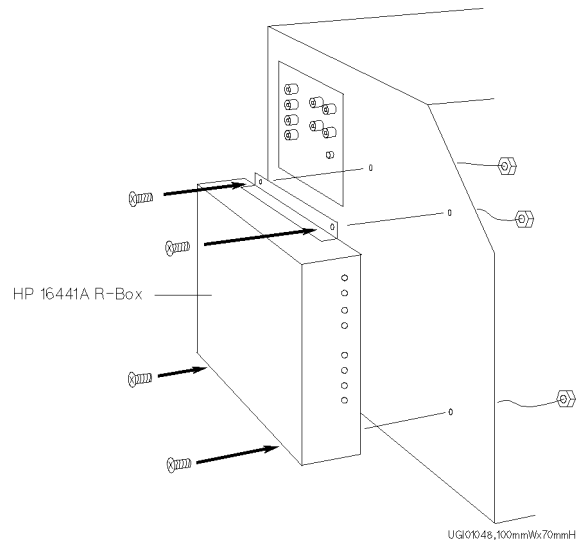

**Attaching HP 16441A R-Box to Shielding Box**

Installation  
**Installing Accessories**

---

## To Install HP 16440A SMU/Pulse Generator Selector

Note that to use the HP 16440A, the HP 4155A/4156A must be equipped with an HP 41501A SMU/Pulse Generator Expander that has two PGUs.

- Attaching your HP 16440A selector to HP 16442A test fixture

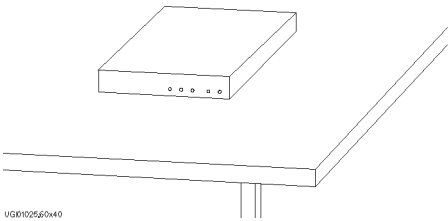
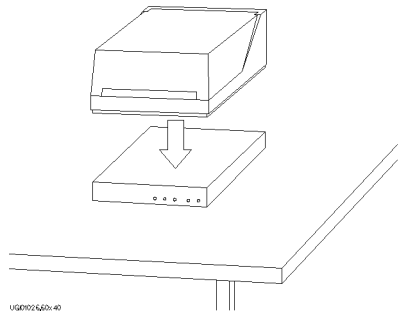
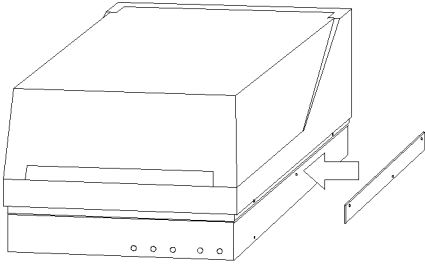
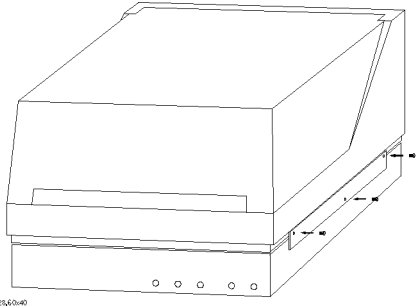
1. Put the HP 16440A selector on your workbench.	2. Put the HP 16442A test fixture on top of HP 16440A selector.
 <p>UG01025620-40</p>	 <p>UG01025620-40</p>
3. Put a plate on both sides.	4. Screw the three furnished flathead screws into each plate.
 <p>UG01027640</p>	 <p>UG01025620-40</p>

If you do *not* use an HP 16440A SMU/Pulse Generator Selector *expander*, skip the following steps:

5. Put the HP 16440A selector *expander* on your workbench. Then, put the HP 16440A selector and HP 16442A test fixture [that were attached in the previous steps] on top of the HP 16440A selector *expander*.

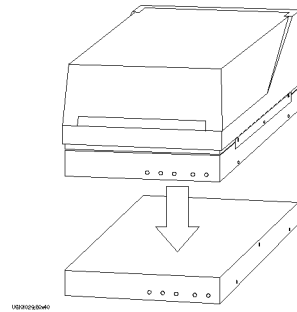

6. Put a plate on both sides.

7. Screw the three furnished flathead screws into each plate.

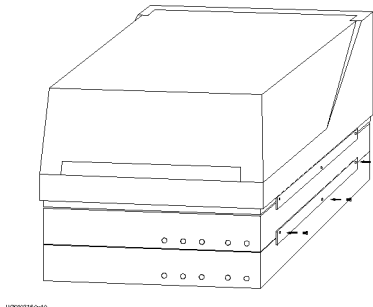
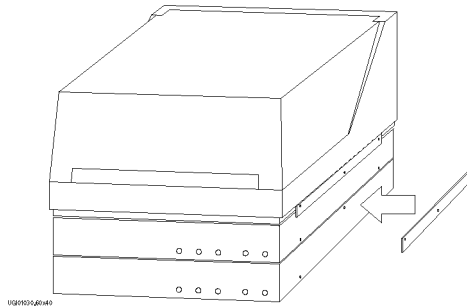

Installation

**Installing Accessories**

You can also attach an HP 16441A R-Box to the HP 16442A test fixture and HP 16440A selector as follows:

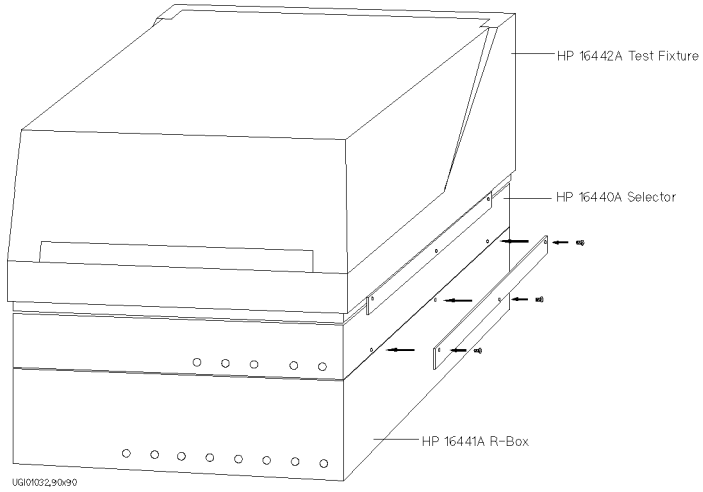

**Attaching R-Box to Test Fixture and Selector**

- Attaching HP 16440A selector to a shielding box

The following figure shows the spacing of the HP 16440A screw holes. You need to prepare four screws and nuts to match the screw holes.

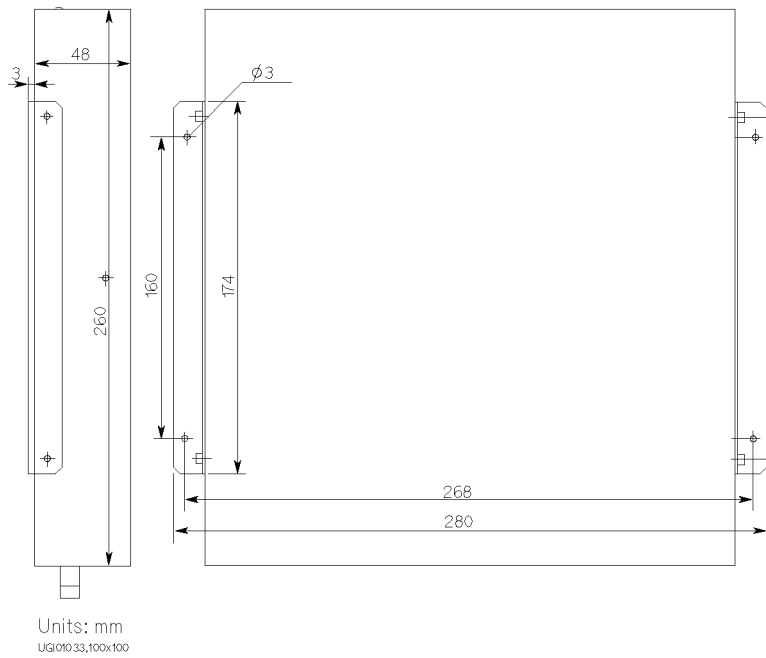



Installation  
**Installing Accessories**

If you also use an HP 16440A selector *expander* with the HP 16440A selector, connect the selector *expander* as follows before connecting to the shielding box:

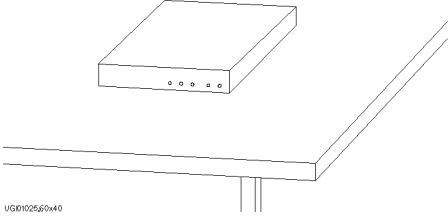
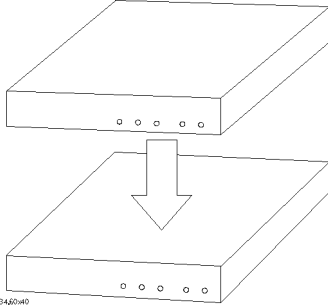
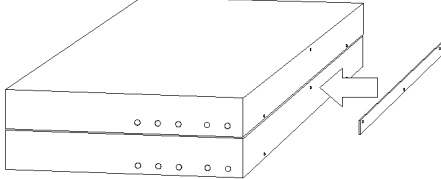
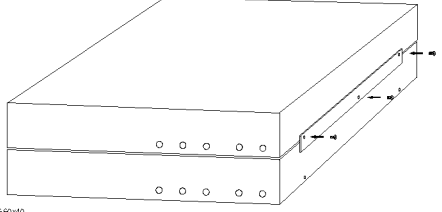
1. Put the selector <i>expander</i> on your workbench.	2. Put the selector on top of selector <i>expander</i> .
 <p>UG0102560140</p>	 <p>UG0103460140</p>
3. Put a plate on both sides.	4. Screw the three furnished flathead screws into each plate.
 <p>UG0103560140</p>	 <p>UG0103660140</p>

Connect selector (and selector *expander* if connected by previous procedure) to shielding box as follows:

1. Attach an angle to both sides of HP 16440A by using the furnished screws.

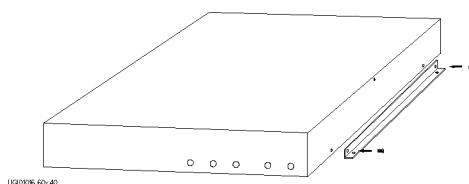

2. Put the HP 16440A(s) on the side panel of your shielding box.
3. Put four nuts on the inside panel of your shielding box.
4. Screw four flathead screws into the side panel.

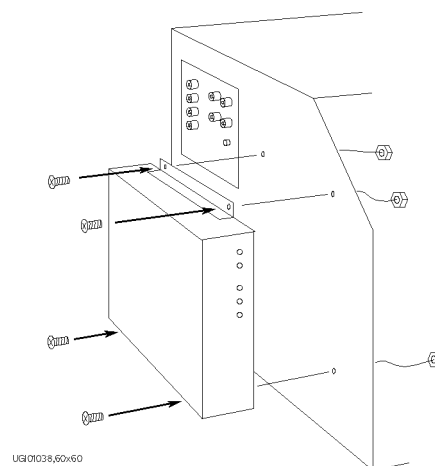

Installation

**Installing Accessories**

You can also attach an HP 16441A R-Box to the HP 16440A selector on the shielding box as follows:

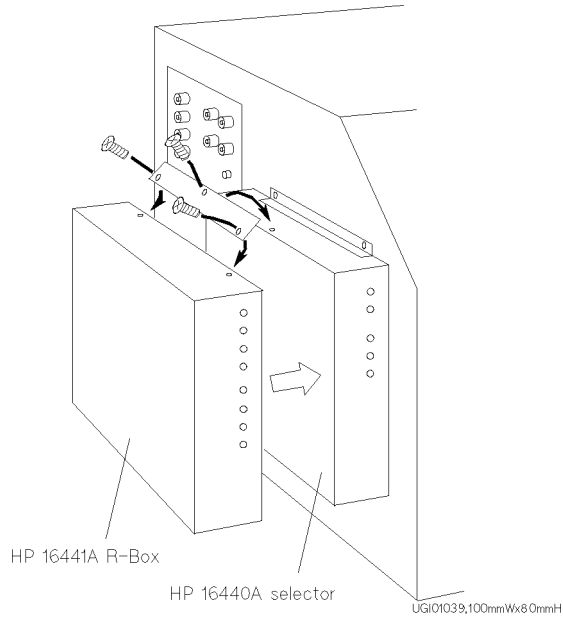

**Attaching HP 16441A R-Box**

---

## To Connect HP 16440A Selector to HP 4155A/56A

- Connecting HP 16440A selector to HP 16440A selector *expander*

If you use selector *expander*, connect selector to selector *expander* by using 40 cm control cable as follows:

CONTROL Output terminal (selector)  $\iff$  CONTROL Input terminal (selector *expander*)

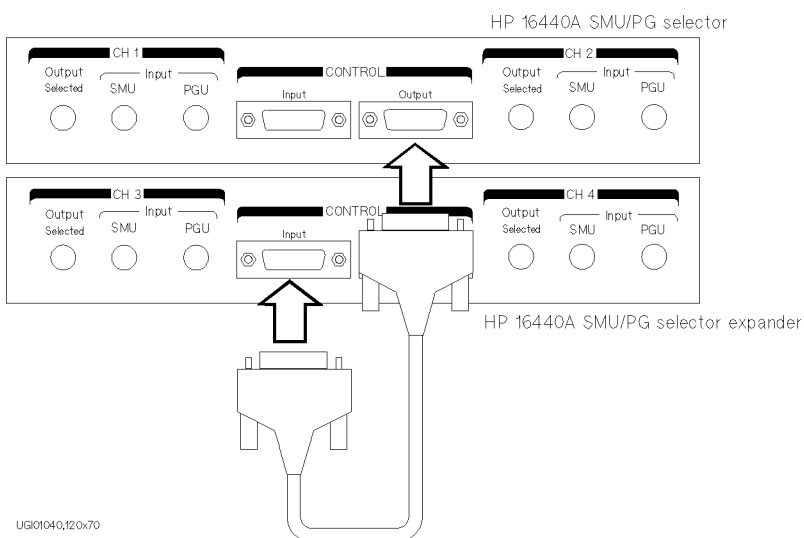

**Installing Accessories**

- Connecting HP 16440A selector to HP 4155A/4156A  
 Before connecting, turn off HP 4155A/4156A and HP 41501A.

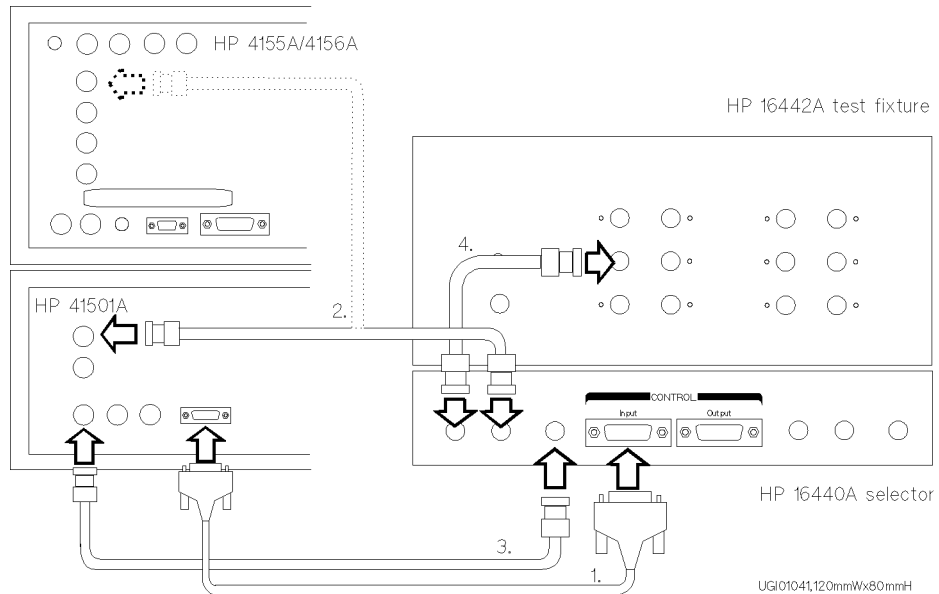

1. Connect the following by using a 3.0 m or 1.5 m control cable:  
**CONTROL Input terminal (selector)  $\iff$  To SMU/Pulse Generator  
 Selector Interface terminal (HP 41501A).**  
*Repeat following steps for desired channels of selector (or expander)*
2. Connect the following by using a 3.0 m or 1.5 m triaxial cable:  
**Input SMU terminal (selector)  $\iff$  SMU terminal (HP 4155A/56A or HP  
 41501A)**
3. Connect the following by using a 3.0 m or 1.5 m coaxial cable:  
**Input PGU terminal (selector)  $\iff$  PGU terminal (HP 41501A).**
4. Connect the following by using a 40 cm triaxial cable:  
**Output Selected terminal (selector)  $\iff$  SMU terminal (connector plate  
 or HP 16442A test fixture).**

**———— Making a Measurement**

---

# Making a Measurement

To make a measurement, mount your device under test (DUT), set up your HP 4155A/4156A for the measurement, then execute the measurement. The HP 4155A/4156A can execute sweep and sampling measurements. The HP 4155A/4156A can also force stress to your DUT.

This chapter describes the tasks for making measurements, and is organized into the following four sections:

- Connection to Device Under Test (DUT)
- Sweep Measurements
- Knob Sweep Measurements
- Sampling Measurements
- Stress Force

For details about how to enter or input setup data, refer to “Page Organization” in *HP 4155A/4156A User’s Dictionary Reference*.

To satisfy the specifications of HP 4155A/4156A and HP 41501A measurement accuracy, perform calibration and adjustment every year and allow HP 4155A/4156A and HP 41501A to warm-up for a minimum of 40 minutes before you begin performing measurements.

---

## Connection to Device Under Test (DUT)

This section describes how to connect your DUTs to the HP 4155A/4156A. Only the basic operations for connecting are described.

If the HP 4155A/4156A is not configured with a test fixture or your wafer prober yet, see “Setting up HP 4155A/4156A” in Chapter 2, *Test Fixture User’s Guide*, and your wafer prober manuals.

This section covers the HP 16442A test fixture only. For operating your wafer prober, see your wafer prober manuals.

Note that you must set the HP 4155A/4156A to the idle state when connecting or disconnecting your DUTs. If not, the DUTs may be damaged. To set to idle state, press **(Stop)** key and make sure Standby indicator is off.

The HP 4156A is designed for Kelvin connections. See “To Make Connections to Measure Low Resistance (For HP 4156A Only)” for Kelvin connection theory.

### **In this Section.**

This section has the following task descriptions:

- To mount a DUT on test fixture
- To make connections to reduce leakage current
- To make connections to measure low resistance (for HP 4156A only)



---

## To Mount a DUT on Test Fixture

1. Set your HP 4155A/4156A to idle state by pressing **(Stop)** key in the MEASUREMENT key group. If the standby indicator is lit, press the **(Standby)** key to turn off the standby indicator.
2. Select a proper socket module for your DUT, then set the module on the test fixture.
3. Mount your DUT on the socket module.
4. Connect the terminals of the socket module to the terminals of the test fixture by using the proper cables.
5. Close the lid of the test fixture, if necessary.

When the HP 4155A/4156A forces more than  $\pm 40$  V, close the lid of the test fixture. Otherwise, the interlock function will stop the HP 4155A/4156A output.

---

### **CAUTION**

---

Do not connect or disconnect your DUT and HP 4155A/4156A while the HP 4155A/4156A is forcing voltage or current. Otherwise, your DUT may be damaged.

To connect the DUT on the test fixture, you can use cables that have the following connectors:

- Miniature banana—miniature banana
- Miniature banana—pin plug
- Miniature banana—miniature clip

---

### **CAUTION**

---

Do not touch the contact part of the connection cables. Oil, perspiration, and dirt prevent good electrical contact, deteriorate insulation, and degrade measurement accuracy.

### Connections for High Current Measurement (HP 4156A Only)

When you force or measure a large current, you may want to use a **Kelvin (4-wire) connection** to eliminate the residual resistance effects of test leads and contacts. For example, you can use the following connections as Kelvin connections on the test fixture:

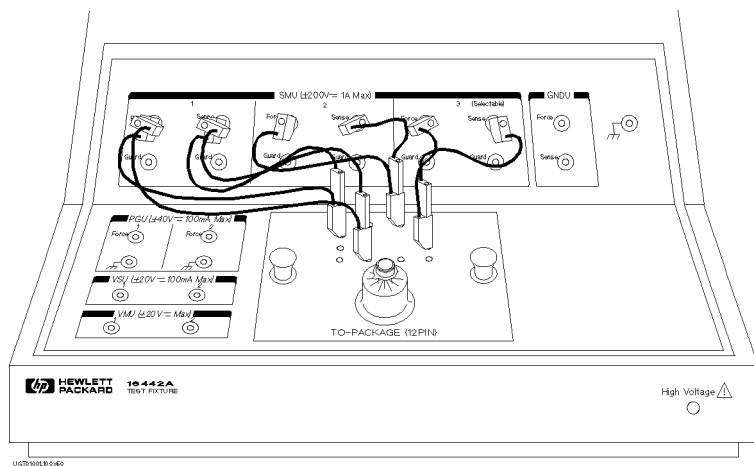

### Examples: Kelvin Connection

To cancel the effects of the residual resistance, test leads must be connected as close as possible to the DUT.

---

## To Make Connections to Reduce Leakage Current

- Connect the terminals of the connector plate to the probing needles by using coaxial cables.
- Connect coaxial center conductor to force terminal (of connector plate) and tail of the probing needle.
- Connect coaxial outer conductor to guard terminal (of connector plate).

To reduce the leakage current, extend the guard conductor as close as possible to the DUT.

---

### **WARNING**

Do not touch the guard terminal with bare hands because you may be shocked by high voltage. The potential of the guard terminal is equal to the output voltage.

---

### **CAUTION**

Never connect the guard terminal to any other output, including circuit common, frame ground, or the guard terminal of any other unit. Doing so may damage the unit.

Example

The following example connection can be used to reduce the leakage current. Extend the outer conductor as close as possible to the probing needle. This also reduces the induced noise.

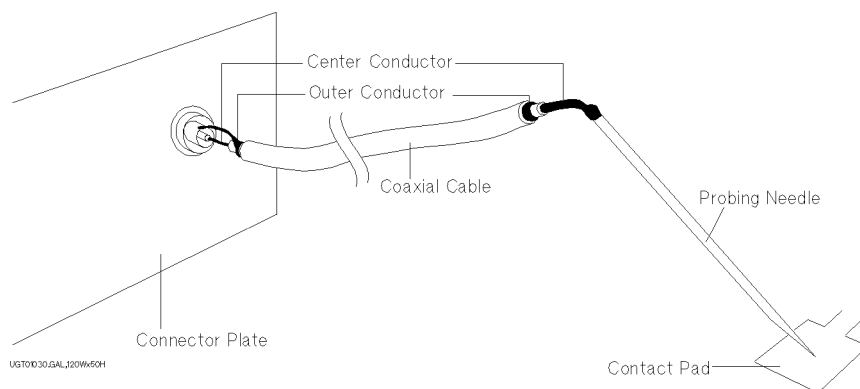

### Guarding

Guarding reduces the leakage current between the measurement points and instrument. This is important when you measure low current.

The following figure shows the theory of guarding. The buffer amplifier ( $\times 1$ ) keeps the potential of the guard conductor at the same potential as the force conductor, so current does not flow between the force and guard conductors. Therefore, the current measured by SMU is same as current at measurement point because no current is leaked.

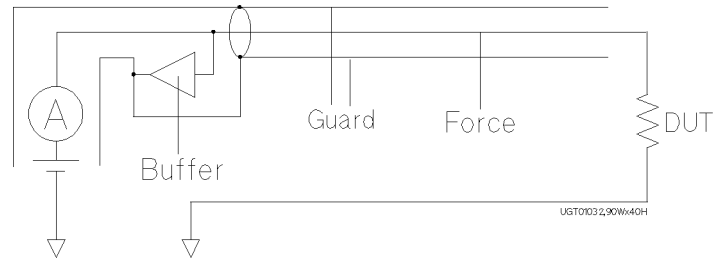

---

## To Make Connections to Measure Low Resistance (For HP 4156A Only)

- Connect force and sense terminals of SMU as close as possible to the DUT.

When you measure a low resistance, high current flows through the DUT. This high current increases the measurement error caused by the residual resistance of cables and contacts. To cancel the effect of this resistance, you can use *Kelvin connections* (4-wire), which means the force and sense lines are extended separately to the DUT.

### Example

The following example connection can be used to measure low resistance. The sense point of the voltage measurement is at the contact pad, so the voltage due to the residual resistance between the instrument and the sense point is canceled.

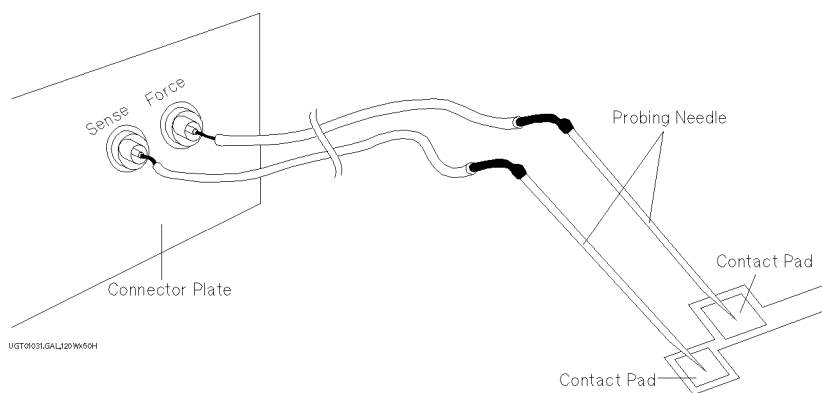

To reduce the leakage current, use coaxial cables to connect the connector plate to the probing needle.

### Kelvin Connection

Kelvin connections give good measurement results when you force high-current. The following figure shows the equivalent circuits for Kelvin and non-Kelvin connections.

- For the non-Kelvin connection, the voltmeter measures the voltage drop of resistances  $r_{F1}$ ,  $R_{DUT}$ , and  $r_{F2}$ .
- For the Kelvin connection, the voltmeter measures the voltage drop of resistance  $R_{DUT}$  only. The impedance of the voltmeter is very high, so the voltage drop of resistances  $r_{S1}$  and  $r_{S2}$  is very small.

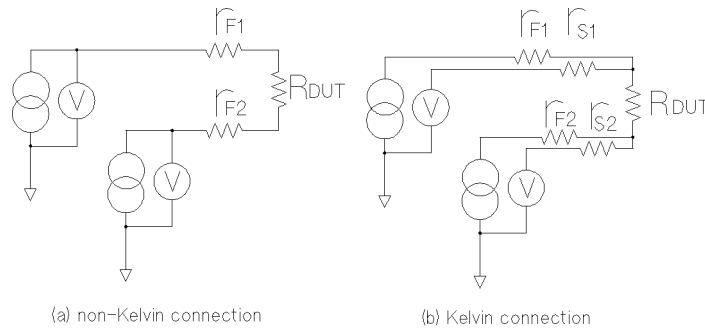

UGT01003.220W650H

The Kelvin connection is effective even when forcing voltage. The voltage drop due to the residual resistance of the force line wiring is fed back to the voltage source via a comparator in the sense line, thereby ensuring the specified voltage output at the sense point (point where force and sense lines intersect). The input impedance of comparator is high, so current flow into the sense line is very low. Therefore, output error is not significant if the sense line wiring has a residual resistance of  $10\Omega$  or less.

# Sweep Measurements

This section describes the sweep measurement tasks.

## Basic Procedures for Sweep Measurements.

The basic procedure to test your DUT is as follows:

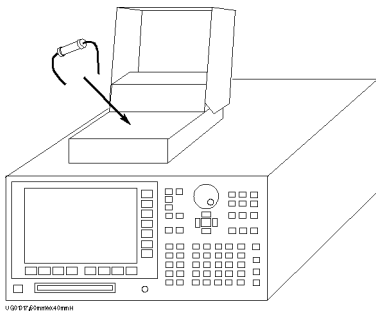
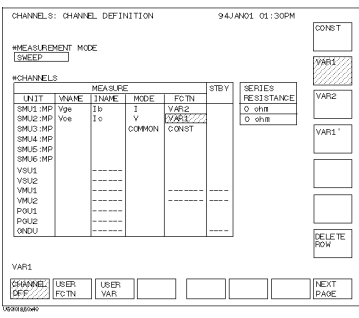
	
<p>1. Connecting your DUT to the HP 4155A/4156A. See "Connection to Device Under Test [DUT]" for procedures.</p>	<p>2. Defining measurement mode and measurement units that you use to make measurement. The following tasks are described:</p> <ul style="list-style-type: none"> <li>• To Define Sweep Measurement Units</li> <li>• To Define a User Function</li> <li>• To Control R-Box</li> </ul>

## Making a Measurement Sweep Measurements

MEASURE: SWEEP SETUP 94JAN01 01:30PM

VARIABLE	VARS1	VARS2	UNIT	VARS1
SWEET	SPR2:HP	SPR1:MP		
NAME	Vce	IB	UNIT	
SWEEP MODE	SINKLE	SINGLE	OFFSET	
LINEAR	LINEAR	LINEAR	RATIO	
START	0 V	0.00 uA	COMPLIANCE	
STOP	5.000 V	500 uA	POWER COMP	
STEP	0.10 V	100 uA	NSM PULSE	
NO OF STEP	51	6	UNIT	
COMPLIANCE	100 mA	S V	NAME	
POWER COMP	OFF	OFF	PERIOD	
WIDTH			WIDTH	
BASE			BASE	

FIELD TIME  
DELAY TIME

\*SWEET CONTINUE AT ANY STATUS

\*CONSTANT

UNIT	NAME	MODE	SOURCE	COMPLIANCE
S.00				

SWEET SETUP POU SETUP MEASURE SETUP OUTPUT VCO PREV PAGE NEXT PAGE

UG00194-0-00

3. Setting the source parameters of the units. The following tasks are described:

- To Set up Primary Sweep Source
- To Set up Secondary Sweep Source
- To Set up Synchronous Sweep Source
- To Set up Constant Output
- To Set up SMU Pulsed Output
- To Set up PGU Pulsed Output

DISPLAY: DISPLAY SETUP 94JAN01 01:30PM

\*DISPLAY MODE  
GRAPHICS

\*GRAPHICS

NAME	Yes Is	VMax Is	V2Max Is
SCALE	LINEAR	LOO	LOO
MIN	0.00000 V	1.0000A	1.0000A
MAX	5.00000 V	100.0000A	100.0000A

\*GRID ON

\*LINE PARAMETER ON

\*DATA VARIABLES

ON

DISPLAY SETUP AUTO ANALYSIS PREV PAGE NEXT PAGE

UG00192-0-00-00

4. Setting the display mode to show measurement results. The following tasks are described:

- To Set up Graphical Display of Measurement Results
- To Set up List Display of Measurement Results

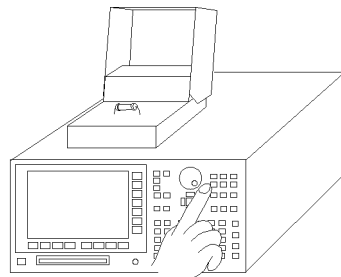

5. Executing the measurement. The following tasks are described:

- To Output Same Value Before and After Measurements
- To Execute or Stop Measurement

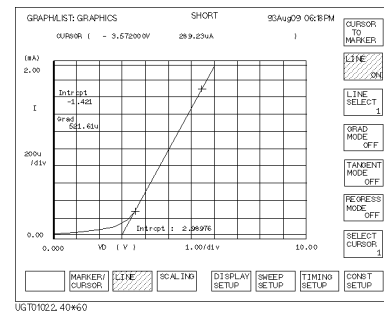

Results. For example, displayed graphically.



## To Define Sweep Measurement Units

1. Press **Chan** key in the PAGE CONTROL key group.
2. Select **CHANNEL DEF** primary softkey.
3. In the MEASUREMENT MODE area, select **SWEEP** secondary softkey.
4. In the VNAME column, enter a unique name for voltage variable. For example, enter **Vce** for collector-emitter voltage. If channel does neither V force nor V measurement, you can omit VNAME.
5. In the INAME column, enter a unique name for current variable. For example, enter **Ic** for collector current. If channel does neither I force nor I measurement, you can omit INAME.
6. In the MODE column, select:
  - **V** secondary softkey for voltage output mode (SMU, VSU, and PGU, and grounded voltage measurement mode of VMU).
  - **I** secondary softkey for current output mode (SMU).
  - **VPULSE** secondary softkey for pulsed voltage output mode (SMU and PGU).
  - **IPULSE** secondary softkey for pulsed current output mode (SMU).
  - **COMMON** secondary softkey for circuit common mode (SMU and GNDU).
  - **DVOLT** secondary softkey for differential voltage measurement mode (VMU).
7. In the FCTN column, select:
  - **CONST** for constant output function (SMU, VSU, and PGU).
  - **VAR1** for primary sweep output function (SMU and VSU).
  - **VAR2** for secondary sweep output function (SMU and VSU).
  - **VAR1'** for synchronous sweep output function (SMU and VSU).

You can use VNAME and INAME names in user function definitions or for analysis on the GRAPHICS/LIST pages. These names must be 6 or less alphanumeric characters. First character must be alphabet character.

For details about STBY and SERIES RESISTANCE fields, see “CHANNELS: CHANNEL DEFINITION page” in “Page Organization” or “Types of Operation State” in “Measurement Functions” of *HP 4155A/4156A User's Dictionary Reference*.

**To disable a unit.**

Move the pointer to the row of the unit, then select the **DELETE ROW** secondary softkey. The settings in the row are deleted.

**Example**

The following settings show an example for measuring an n-p-n transistor's I-V characteristics. SMU1 is connected to base, SMU2 is connected to collector, and SMU3 is connected to emitter. SMU1 is set to current source (I mode) and secondary sweep (VAR2) function. SMU2 is set to voltage source (V mode) and primary sweep (VAR1) function. SMU3 is set to COMMON.

CHANNELS: CHANNEL DEFINITION 94JAN01 01:30PM

\*MEASUREMENT MODE

\*CHANNELS

UNIT	MEASURE				STBY	SERIES RESISTANCE
	VNAME	INAME	MODE	FCTN		
SMU1: MP	Vbe	Ib	I	VAR2		0 ohm
SMU2: MP	Vce	Ic	V	VAR1		0 ohm
SMU3: MP			COMMON	CONST		
SMU4: MP						
SMU5: MP						
SMU6: MP						
VSU1	-----					
VSU2	-----					
VMU1	-----					
VMU2	-----					
PGU1	-----					
PGU2	-----					
GNDU	-----					

VAR1

CONST  
VAR1  
VAR2  
VAR1'  
DELETE ROW

UG01002,100x70

**Example Channel Definition: Sweep Measurement**

## To Set up Primary Sweep Source

1. Define VAR1 unit as described in “To Define Sweep Measurement Units”.
2. Press **Meas** key in the PAGE CONTROL key group.
3. Select **SWEEP SETUP** primary softkey.
4. In the SWEEP MODE field of the VAR1 column, select:
  - **SINGLE** secondary softkey to set single sweep mode.
  - **DOUBLE** secondary softkey to set double sweep mode.
5. In the LIN/LOG field of the VAR1 column, select:
  - **LINEAR** secondary softkey to set linear step mode.
  - **LOG XX** secondary softkey to set logarithmic step mode. **XX** is 10, 25, or 50, which specifies the number of steps per decade.
6. In the START field of the VAR1 column, enter the start value.
7. In the STOP field of the VAR1 column, enter the stop value.
8. In the STEP field of the VAR1 column, enter the step value.

The NO OF STEP is automatically calculated from the start, stop, and step values.

If you select **LOG** for LIN/LOG, the polarity of start and stop values must be the same.

### **To change the compliance value of VAR1.**

Enter desired compliance value into COMPLIANCE field of VAR1 column.

### **To modify the UNIT and NAME fields.**

Modify the UNIT and NAME fields on the CHANNELS: CHANNEL DEFINITION page.

Example

The following example shows the primary sweep conditions (VAR1 parameters):

MEASURE: SWEEP SETUP 94JAN01 01:30PM

*VARIABLE	VAR1	VAR2
UNIT	SMU2:MP	
NAME	Vce	
SWEEP MODE	SINGLE	
LIN/LOG	LINEAR	
START	0 V	
STOP	5.00 V	
STEP	0.10 V	
NO OF STEP	51	
COMPLIANCE	100 mA	
POWER COMP	OFF	

\*TIMING  
 HOLD TIME 0.0 s  
 DELAY TIME 0.000 s

\*SWEEP CONTINUE AT ANY Status

\*CONSTANT

UNIT				
NAME				
MODE				
SOURCE				
COMPLIANCE				

5.00

SWEEP SETUP PGU SETUP MEASURE SETUP OUTPUT SEQ PREV PAGE NEXT PAGE

UG01003,90x70

---

## To Set up Secondary Sweep Source

1. Define VAR2 unit as described in “To Define Sweep Measurement Units”.
2. Press **Meas** key in the PAGE CONTROL key group.
3. Select **SWEEP SETUP** primary softkey.
4. In the START field of the VAR2 column, enter the start value.
5. In the STEP field of the VAR2 column, enter the step value.
6. In the NO OF STEP field of the VAR2 column, enter the number of steps.

To output secondary sweep source, you also need to set up primary sweep source. For details of how to set up primary sweep source, refer to “To Set up Primary Sweep Source”.

For secondary sweep source, the following is always set automatically:  
SWEEP MODE is set to SINGLE, and LIN/LOG is set to LINEAR. You cannot modify the SWEEP MODE and LIN/LOG fields for the secondary sweep source.

The STOP value is automatically calculated from the start value, step value, and the number of steps.

### **To change the compliance value of VAR2.**

Enter desired compliance value into COMPLIANCE field of VAR2 column.

### **To modify the UNIT and NAME fields.**

Modify the UNIT and NAME fields on the CHANNELS: CHANNEL DEFINITION page.

Example

The following example shows the secondary sweep conditions (VAR2 parameters):

MEASURE: SWEEP SETUP 94JAN01 01:30PM

	VAR1	VAR2
UNIT	SMU2:MP	SMU1:MP
NAME	Vce	Ib
SWEEP MODE	SINGLE	SINGLE
LIN/LOG	LINEAR	LINEAR
START	0 V	0.00 uA
STOP	5.00 V	500 uA
STEP	0.10 V	100 uA
NO OF STEP	51	6
COMPLIANCE	100 mA	5 V
POWER COMP	OFF	OFF

\*TIMING  
 HOLD TIME 0.0 s  
 DELAY TIME 0.000 s

\*CONSTANT \*SWEEP CONTINUE AT ANY Status

UNIT				
NAME				
MODE				
SOURCE				
COMPLIANCE				

0.0001

SWEEP SETUP PGU SETUP MEASURE SETUP OUTPUT SEQ PREV PAGE NEXT PAGE

UG01004,90x70

## To Set up Synchronous Sweep Source

1. Define VAR1' unit as described in "To Define Sweep Measurement Units".
2. Press **Meas** key in the PAGE CONTROL key group.
3. Select **SWEEP SETUP** primary softkey.
4. In the OFFSET field of the VAR1' column, enter the offset value.
5. In the RATIO field of the VAR1' column, enter the ratio value.

The output value of VAR1' is calculated by the following equation:

$$VAR1' = VAR1 \times RATIO + OFFSET$$

To output synchronous sweep source, you also need to set up primary sweep source VAR1. For details of how to set up VAR1, refer to "To Set up Primary Sweep Source". VAR1 and VAR1' must both be voltage output mode or both current output mode. For example, if VAR1 is V output mode, then VAR1' must be V or VPULSE output mode.

### **To change the compliance value of VAR1'.**

Enter desired compliance value into COMPLIANCE field of VAR1' column.

### **To modify the UNIT and NAME fields.**

Modify the UNIT and NAME fields on the CHANNELS: CHANNEL DEFINITION page.

Example

The following example shows the synchronous sweep conditions (VAR1' parameters):

MEASURE: SWEEP SETUP 94JAN01 01:30PM

*VARIABLE	VAR1	VAR2	VAR1'
UNIT	SMU2:MP	SMU1:MP	SMU3:MP
NAME	Vce	Ib	Vsync
SWEEP MODE	SINGLE	SINGLE	0.00
LIN/LOG	LINEAR	LINEAR	<input type="checkbox"/>
START	0 V	0.00 uA	<input type="checkbox"/>
STOP	5.00 V	500 uA	<input type="checkbox"/>
STEP	0.10 V	100 uA	<input type="checkbox"/>
NO OF STEP	51	6	<input type="checkbox"/>
COMPLIANCE	100 mA	5 V	<input type="checkbox"/>
POWER COMP	OFF	OFF	<input type="checkbox"/>

\*TIMING

HOLD TIME  \*SWEEP  Status

DELAY TIME

\*CONSTANT

UNIT	NAME	MODE	SOURCE	COMPLIANCE

0.01

SWEEP SETUP  
  PGU SETUP  
  MEASURE SETUP  
  OUTPUT SEQ  
   
   
  PREV PAGE  
  NEXT PAGE

UG01005,90x70



## To Set up Constant Output

1. Define CONST units as described in “To Define Sweep Measurement Units”.
2. Press **Meas** key in the PAGE CONTROL key group.
3. Select **SWEEP SETUP** primary softkey.
4. In the SOURCE field of the desired unit in the CONSTANT area, enter the desired output value.

### To modify the UNIT, NAME, and MODE fields.

Modify the UNIT, NAME, and MODE fields on the CHANNELS: CHANNEL DEFINITION page.

Example

The following example shows the constant output conditions:

MEASURE: SWEEP SETUP 94JAN01 01:30PM

*VARIABLE	VAR1	VAR2
UNIT	SMU1:MP	
NAME	I f	
SWEEP MODE	SINGLE	
LIN/LOG	LOG 10	
START	1.00 uA	
STOP	1.00 mA	
STEP	-----	
NO OF STEP	31	
COMPLIANCE	100 mV	
POWER COMP	OFF	

\*TIMING

HOLD TIME 0.0 s

DELAY TIME 0.000 s

\*CONSTANT \*SWEEP **CONTINUE AT ANY** Status

UNIT	SMU2:MP			
NAME	V off			
MODE	V			
SOURCE	1.000 V			
COMPLIANCE	100 mA			

1.00

UG01006,90x70

---

## To Set up SMU Pulsed Output

1. Define SMU to be VPULSE or IPULSE mode as described in “To Define Sweep Measurement Units”.
  - For pulsed sweep source, specify SMU FCTN to be VAR1, VAR2, or VAR1’.
  - For pulsed constant source, specify SMU FCTN to be CONST.
2. Press **Meas** key in the PAGE CONTROL key group.
3. Select **SWEEP SETUP** primary softkey.
4. Set as follows:
  - For pulsed sweep source, set up VAR1, VAR2, or VAR1’ area.
  - For pulsed constant source, set up CONSTANT area.
5. In the PERIOD field of the SMU PULSE area, enter the pulse period value.
6. In the WIDTH field of the SMU PULSE area, enter the pulse width value.
7. In the BASE field of the SMU PULSE area, enter the pulse base value.

On the CHANNEL DEFINITION page, you can set *only one* SMU to be a pulsed source. Then, you set the pulse parameters in the SMU PULSE area of the SWEEP SETUP page.

The relation between the PERIOD, WIDTH, and BASE values are as shown in the following figures.

For figure (a), the SMU is set on the CHANNELS: CHANNEL DEFINITION page as follows:

- MODE: VPULSE or IPULSE
- FCTN: VAR1, VAR2, or VAR1’

For figure (b), the SMU is set on the CHANNELS: CHANNEL DEFINITION page as follows:

- MODE: VPULSE or IPULSE
- FCTN: CONST

Making a Measurement  
**Sweep Measurements**

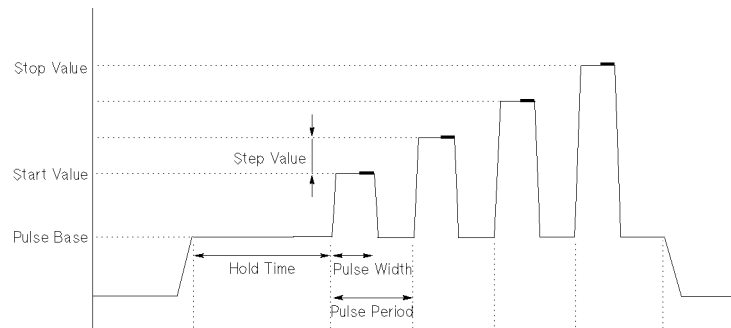

(a) For Pulsed Sweep Source

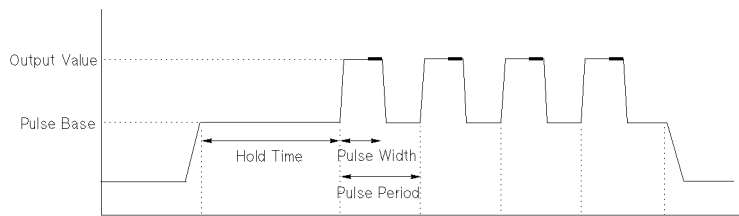

(b) For Pulsed Constant Source

UG000727x110

The pulse peak values depend on the values you set in the VAR1, VAR1', VAR2, or CONSTANT area.

**To modify the UNIT and NAME fields.**

Modify the UNIT and NAME fields on the CHANNELS: CHANNEL DEFINITION page.

Example

The following shows an example setup of SMU pulsed output on the MEASURE: SWEEP SETUP page.

MEASURE: SWEEP SETUP 94JAN01 01:30PM

*VARIABLE	VAR1	VAR2
UNIT	SMU1:MP	
NAME	If	
SWEEP MODE	SINGLE	
LIN/LOG	LOG 10	
START	1.00 uA	
STOP	1.00 mA	
STEP	-----	
NO. OF STEP	31	
COMPLIANCE	100 mV	
POWER COMP	-----	

\*TIMING

HOLD TIME

\*SMU PULSE

UNIT	SMU1:MP
NAME	If
PERIOD	10.0ms
WIDTH	1.00ms
BASE	0.000 A

\*SWEEP  Status

\*CONSTANT

UNIT	SMU2:MP			
NAME	Voff			
MODE	V			
SOURCE	5.000 V			
COMPLIANCE	100 mA			

0.001

<input checked="" type="checkbox"/> SWEEP SETUP	<input type="checkbox"/> PDU SETUP	<input type="checkbox"/> MEASURE SETUP	<input type="checkbox"/> OUTPUT SEQ	<input type="checkbox"/>	<input type="checkbox"/>	<input type="checkbox"/> PREV PAGE	<input type="checkbox"/> NEXT PAGE
---	------------------------------------	--	-------------------------------------	--------------------------	--------------------------	------------------------------------	------------------------------------

UG01039,90x70

## To Set up PGU Pulsed Output

1. Define PGU to be VPULSE and CONST as described in “To Define Sweep Measurement Units”.
2. Press **Meas** key in the PAGE CONTROL key group.
3. Select **PGU SETUP** primary softkey.
4. In the PERIOD field of PGU1, enter the pulse period value.
5. In the WIDTH field of desired PGU column, enter the pulse width value.
6. In the DELAY TIME field of desired PGU column, enter delay time value.
7. In the PEAK VALUE field of desired PGU column, enter pulse peak value.
8. In the BASE VALUE field of desired PGU column, enter pulse base value.
9. In the LEADING TIME field of desired PGU column, enter the leading-edge transition time.
10. In the TRAILING TIME field of desired PGU column, enter the trailing-edge transition time.
11. In the IMPEDANCE field of desired PGU column, select:
  - **LOW** secondary softkey for approximately zero ohm output impedance.
  - **50 ohm** secondary softkey for 50 ohm output impedance.
12. In the PULSE COUNT field, do one of the following:
  - Select **FREE RUN** secondary softkey to force the pulse continuously.
  - Or enter the number of pulses to output (for sampling measurement only).

For the pulse period and pulse count values, the values you set for PGU1 are also used for PGU2.

The following figure shows the relation between pulse waveform and setup parameters.

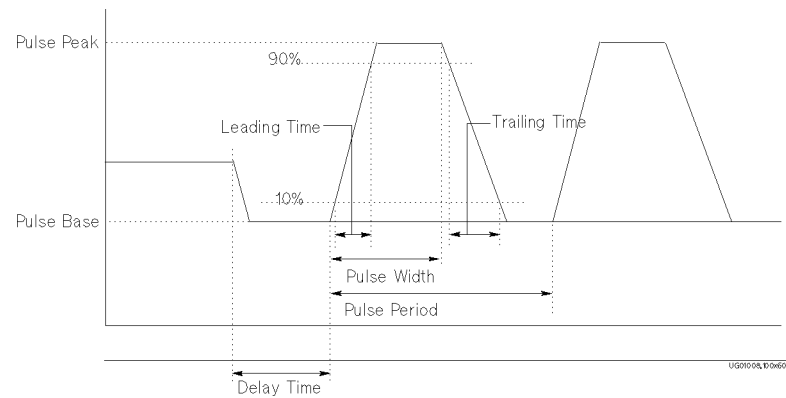

You cannot set compliance for a PGU, which has a 100 mA current limit.

**To modify the UNIT and NAME fields.**

Modify the UNIT and NAME fields on the CHANNELS: CHANNEL DEFINITION page.

**Using PGUs as Constant Voltage Source**

To use a PGU as a constant voltage source, set the desired PGU as follows:

- V in MODE column on the CHANNEL DEFINITION page
- Desired output voltage value in SOURCE field on MEASURE: PGU SETUP page.

Making a Measurement  
**Sweep Measurements**

Example

The following example shows setup of PGU pulsed output on the MEASURE: PGU SETUP page.

MEASURE: PGU SETUP 94 JAN01 01:30PM

*PULSE		
UNIT	PGU1	PGU2
NAME		
PERIOD	10.00ms	-----
WIDTH	5.00ms	
DELAY TIME	0.00000 s	
PEAK VALUE	1.00mV	
BASE VALUE	0.00 V	
LEADING TIME	100ns	
TRAILING TIME	100ns	
IMPEDANCE	LOW	
PULSE COUNT	0	-----

*CONSTANT		
UNIT	PGU1	PGU2
NAME		
SOURCE		

0.00500

UG01040,100x70

---

## To Output Same Value Before and After Measurements

1. Press **(Chan)** key in the PAGE CONTROL key group.
2. Select **CHANNEL DEF** primary softkey.
3. In the STBY column of the desired unit, select **STANDBY ON** secondary softkey.
4. Press **(Standby)** key in the MEASUREMENT key group.

The indicator above the **(Standby)** key shows whether the Standby function is enabled. If this indicator is ON, then for the units that you selected **STANDBY ON**, the units have the following output value during the Standby state (that is, before and after measurements or stress):

Function of a Unit	Output during Standby State
VAR1	VAR1 Start value
VAR1'	Ratio × Start + Offset
VAR2	VAR2 Start value
CONSTANT	Output value

For sampling measurements, only the CONSTANT function is available.

From Standby state, you can execute measurements or force stress by pressing **(Single)**, **(Repeat)**, **(Append)**, or **(Stress)** key. After measurement or stress, the STANDBY ON units are returned to same output value as before measurement or stress.

If Standby indicator is ON, then pressing the **(Standby)** key disables the Standby function, and Standby output stops. Pressing the **(Stop)** key has no affect on the Standby state.



## To Define a User Function

1. Press **Chan** key in the PAGE CONTROL key group.
2. Select **USER FCTN** primary softkey.
3. In the NAME column, enter the user function name.
4. In the UNIT column, enter the units.
5. In the DEFINITION column, enter the user function definition.

The user function name must be 6 or less alphanumeric characters. First character must be alphabet character. Name must be unique. Name is case sensitive. For example, HFE is different from Hfe.

In the user function definition, you can enter an expression that consists of any of the following:

- VNAME and INAME names that you entered on the CHANNELS: CHANNEL DEFINITION page.
- Other user functions.
- Numerical operators.
- Built-in functions such as **DELTA** and **SQRT**.

For details about expressions, numerical operators, and built-in functions, refer to “Data Variable and-Analysis Function” in *HP 4155A/4156A User’s Dictionary Reference*.

Example

The following figure shows an example setup to define **Hfe**.

CHANNELS: USER FUNCTION DEFINITION 94JAN01 01:30PM

NAME	UNIT	DEFINITION
Hfe		Ic/Ib

Vbe

Ib

Vce

Ic

Ic/Ib

CHANNEL DEF USER FCN USER VAR

PREV PAGE NEXT PAGE

UG01041,100x70

---

## To Set up Graphical Display of Measurement Results

1. Press **Display** key in the PAGE CONTROL key group.
2. Select **DISPLAY SETUP** primary softkey.
3. In the DISPLAY MODE field, select **GRAPHICS** secondary softkey.
4. In the Xaxis column, enter variable name, select axis scale, and enter minimum and maximum values.
5. In the Y1axis column, enter variable name, select axis scale, and enter minimum and maximum values.
6. If you use Y2 axis, enter variable name, select axis scale, and enter minimum and maximum values in Y2axis column.

When the pointer is in the NAME row, the allowable variable names appear in the secondary softkey area. To set a variable name, select the desired secondary softkey. The allowable names are names that you already set up on the CHANNEL DEFINITION, USER FUNCTION, and USER VARIABLE pages.

### **To display a grid on the plotting area.**

In GRID field, select **ON** secondary softkey.

### **To remove the grid.**

In GRID field, select **OFF** secondary softkey.

### **To control display of line parameters on GRAPHICS page.**

In LINE PARAMETER field, select **ON** to display or **OFF** to not display. Line parameters are the X and Y intercepts and gradient of the analysis lines.

### **To set up variable to be displayed on the GRAPHICS page.**

In DATA VARIABLES fields, select secondary softkey for desired variable.

Example

The following figure shows an example to set up both Y1 and Y2 axes, and to set grid to ON.

DISPLAY: DISPLAY SETUP 94JAN01 01:30PM

\*DISPLAY MODE  
 GRAPHICS

\*GRAPHICS

	Xaxis	Y1axis	Y2axis
NAME	VE	IC	IB
SCALE	LINEAR	LOG	LOG
MIN	0.000000 V	1.000pA	1.000pA
MAX	1.000000 V	100.000mA	100.000mA

\*GRID  
 ON

\*LINE PARAMETER  
 ON

\*DATA VARIABLES

ON  DISPLAY SETUP AUTO ANALYSIS     B  PREV PAGE  NEXT PAGE

UG01037.100x70

---

## To Set up List Display of Measurement Results

1. Press **Display** key in the PAGE CONTROL key group.
2. Select **DISPLAY SETUP** primary softkey.
3. In the DISPLAY MODE field, select **LIST** secondary softkey.
4. In the LIST area, select the secondary softkey of the variables for which you want to list the measurement results.

When the pointer is in the NAME row, the allowable variable names appear in the secondary softkey area. To set a variable name, select the desired secondary softkey. The allowable names are names that you already set up on CHANNEL DEFINITION, USER FUNCTION, and USER VARIABLE pages.

### To set up variable to be displayed on the LIST page.

In DATA VARIABLES fields, select secondary softkey for desired variable.

Example

Following figure is an example setup to display VE, IC, and IB on LIST page.

DISPLAY: DISPLAY SETUP 94JAN01 01:30PM

\*DISPLAY MODE  
LIST

\*LIST

No.	NAME
1	VE
2	IC
3	IB
4	
5	
6	
7	
8	

\*DATA VARIABLES

--

IB

VE  
VC  
VB  
IE  
IC  
IB  
MORE  
1/2

DISPLAY SETUP AUTO ANALYSIS PREVIOUS PAGE NEXT PAGE

UG01038,100\*70

---

## To Execute or Stop Measurement

- To execute a measurement, press:
  - **Single** key in the MEASUREMENT key group for single measurement.
  - **Repeat** key in the MEASUREMENT key group for repeat measurement.
  - **Append** key in the MEASUREMENT key group for append measurement.
- To stop a measurement, press **Stop** key in the MEASUREMENT key group.

### **Single, Repeat, and Append Measurement**

There are three measurement execution modes as follows:

Single measurement	Clears GRAPHICS or LIST page, then executes measurement one time. Measurement results are displayed on GRAPHICS or LIST page.
Repeat measurement	Executes measurements continuously. Before each measurement is executed, the GRAPHICS or LIST page is cleared. Most recent measurement results are displayed on GRAPHICS or LIST page.
Append measurement	Executes measurement one time. Does <i>not</i> clear GRAPHICS or LIST page. That is, measurement results are added to the existing results.

## To Control R-Box

1. Connect HP 16441A R-Box to HP 4155A/4156A and to HP 16442A Test Fixture or connector plate on your shield box. For details about connections, refer to “Connections” in *HP 4155A/4156A User’s Dictionary Reference*.
2. Press **Chan** front-panel key of the PAGE CONTROL key group.
3. Select **CHANNEL DEF** primary softkey to display the CHANNELS: CHANNEL DEFINITION page.
4. In the SERIES RESISTANCE fields, select:
  - **0 ohm** secondary softkey to connect 0  $\Omega$  resistance.
  - **10k ohm** secondary softkey to connect 10 k $\Omega$  resistance.
  - **100k ohm** secondary softkey to connect 100 k $\Omega$  resistance.
  - **1M ohm** secondary softkey to connect 1 M $\Omega$  resistance.

Resistance is switched just before and just after measurement state. In the standby state, the stress force state, and the idle state, 0  $\Omega$  is connected.

HP 4155A/4156A automatically compensates for the resistance values.

For the following SMUs, you can set 0  $\Omega$  *only*:

- SMU that is set to **ON** in the STBY field.
- SMU that is set to **COMMON** in the MODE field.

You can set resistance values for the following SMUs.

- If HP 41501A SMU/Pulse Generator Expander is not installed or does not have an HPSMU
  - SMU1 (to CH1 terminal of R-Box)
  - SMU2 (to CH2 terminal of R-Box)
- If HP 41501A has an HPSMU
  - SMU1 (to CH1 terminal of R-Box)
  - SMU5 (to CH2 terminal of R-Box)

Example

The following figure shows an example setup to connect 10 kΩ resistance to SMU1 and SMU2.

CHANNELS: CHANNEL DEFINITION 94JAN01 01:30PM

\*MEASUREMENT MODE

\*CHANNELS

UNIT	VNAME	MEASURE			STBY	SERIES RESISTANCE
		INAME	MODE	FCTN		
SMU1:MP	Vbe	Ib	I	VAR2		
SMU2:MP	Vce	Ic	V	VAR1		
SMU3:MP			COMMON	CONST		
SMU4:MP						
SMU5:MP						
SMU6:MP						
VSU1		-----				
VSU2		-----				
VMU1		-----				
VMU2		-----				
PGU1		-----				
PGU2		-----				
GNDU		-----				

10k ohm

CHANNEL DEF  
 USER FCTN  
 USER VAR  
 NEXT PAGE

UG01035,100kV0



Making a Measurement  
**Sweep Measurements**

**To Measure Negative Resistance Characteristics**

HP 16441A R-Box allows SMUs to measure current-controlled negative resistance ( $\leq 1 \text{ M}\Omega$ ) characteristics.

Connect the resistance of HP 16441A as shown in following figure.

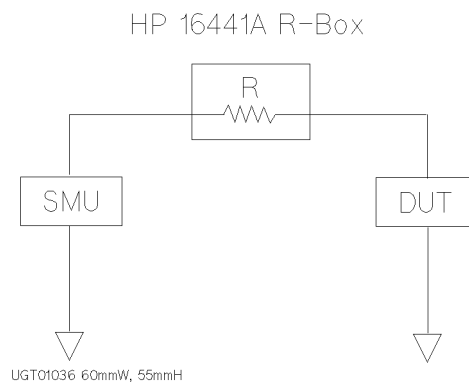

---

# Knob Sweep Measurements

This section covers the following tasks about knob sweep measurements.

- To execute knob sweep measurement
- To stop knob sweep measurement

The knob sweep function is useful in the following cases:

- when you want to determine a parameter value for normal sweep
- when you want to quickly make a rough measurement of a DUT characteristics

The following figure shows the KNOB SWEEP page.

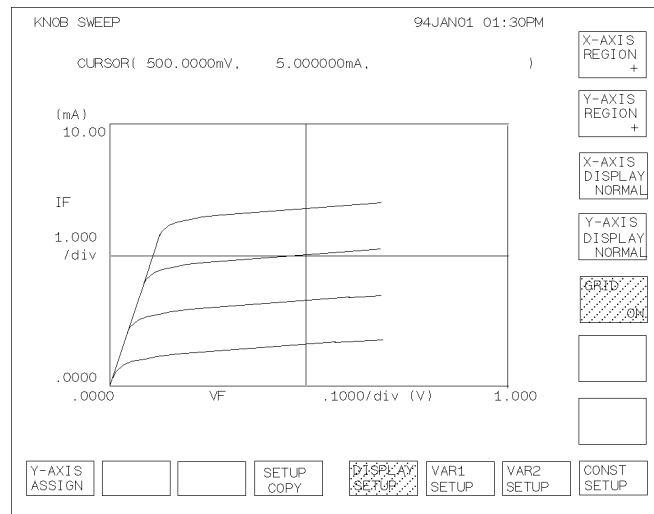

---

## To Execute Knob Sweep Measurement

1. Define the measurement units on the CHANNELS: CHANNEL DEFINITION page as described in “To Define Sweep Measurement Units”.
2. Set the sweep information on the MEASURE: SWEEP SETUP page.

For details, refer to the following:

- “To Set up Primary Sweep Source”
- “To Set up Secondary Sweep Source”
- “To Set up Constant Output”

3. Set the MEASURE: PGU SETUP page (if you use PGUs).
4. Press the green key. Then, press **Single** front-panel key to display the KNOB SWEEP page.
5. Select **DISPLAY SETUP** primary softkey to display DISPLAY SETUP secondary key group.
6. Select **X-AXIS REGION** secondary softkeys to set the desired X axis display region. Selecting the **X-AXIS REGION** secondary softkey toggles as follows:

+ → - → +/- → +

7. Select **Y-AXIS REGION** secondary softkeys to set the desired Y axis display region. Selecting the **Y-AXIS REGION** secondary softkey toggles as follows:

+ → - → +/- → +

8. Rotate the rotary knob to stretch or shrink the measurement curve.

If you set constant outputs or PGU output in step 2 or 3, the outputs start immediately after you perform step 4.

During measurements, self-test, or forcing stress, step 4 is ignored.

Note the following restrictions:

- CHANNELS: CHANNEL DEFINITION page

- MEASUREMENT MODE field

- In the MEASUREMENT MODE field, be sure to set **SWEEP**. If you select **SAMPLING MODE**, you cannot execute knob sweep measurement.

- MODE field

- Pulsed SMU (**VPULSE** and **IPULSE**) are not available for knob sweep measurement.

- FCTN field

- VARI' is not available for knob sweep measurement.

- MEASURE: SWEEP SETUP page

- You cannot use the power compliance function for knob sweep measurement.

**To change the variable assigned to y axis.**

Do as follows:

1. Press **Stop** front-panel key.
2. Select **Y-AXIS ASSIGN** primary softkey.
3. Select a secondary softkey to assign the desired variable name to y axis.

The available variables are the variables you entered in the INAME and VNAME columns of the CHANNELS: CHANNEL DEFINITION page. You cannot use user functions or user variables.

**To copy setups on the knob sweep page.**

Select **SETUP COPY** primary softkey to copy setups on this page to the MEASURE: SWEEP SETUP and DISPLAY: DISPLAY SETUP pages.

## Knob Sweep Measurements

### If you ignore restrictions for knob sweep setup

If CHANNELS or MEASURE page group have settings that are not available for knob sweep measurements, a warning message is displayed, then the following primary softkeys are displayed.

- **STOP**
- **CONT**

If you select **CONT** softkey, HP 4155A/4156A performs knob sweep measurement as follows:

- If VAR1' is set in the FCTN field on the CHANNELS: CHANNEL DEFINITION page:  
The channel that is set to VAR1' set to CONST (output value: VAR1' start). So synchronous measurement is not performed.
- If an SMU is set to VPULSE or IPULSE the MODE field on the CHANNELS: CHANNEL DEFINITION page:  
Non-pulsed sweep measurement is performed.
- If the POWER COMP fields are set on the MEASURE: SWEEP SETUP page:  
The specified values are ignored. Measurement is performed the same as if OFF is selected.

If you select **STOP** softkey, the incorrect setting is highlighted, and you can correct it.

Example

The following figure shows an example to set both X axis and Y axis display regions to positive.

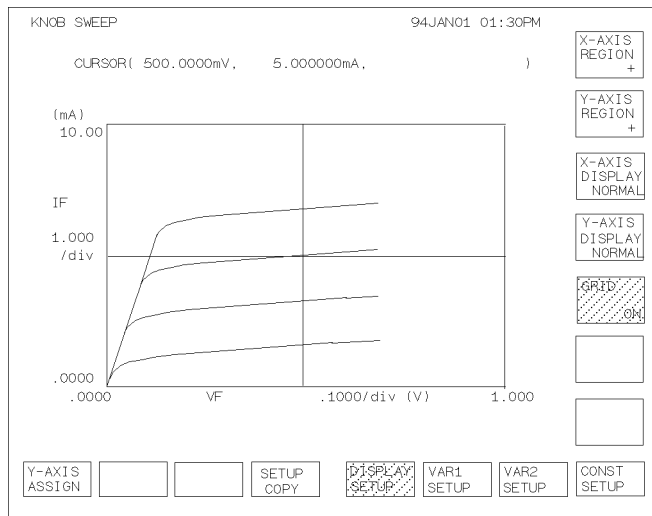

UGT01034, 100\*70

---

## To Stop Knob Sweep Measurement

- Press **(Stop)** front-panel key.

If you execute knob sweep measurement from the idle state, pressing **(Stop)** front-panel key returns to the idle state.

If you execute knob sweep measurement from the standby state, pressing **(Stop)** front-panel key returns to the standby state.

### **Starting knob sweep again after pressing **(Stop)** front-panel key**

If you stop knob sweep measurement, then start the measurement again, the measurement start point depends on how you start the measurement.

- started by **(Single)** front-panel key *only*

If you press the **(Single)** front-panel key, the knob sweep measurement starts from the point where it was stopped by **(Stop)** front-panel key.

- started by green key and **(Single)** front-panel key

If you press the green key, then press **(Single)** front-panel key, the knob sweep measurement starts from 0 V or 0 A.

# Sampling Measurements

This section covers the tasks for sampling measurements.

## Basic Procedures for Sampling Measurements.

The basic procedure to test your DUT is as follows:

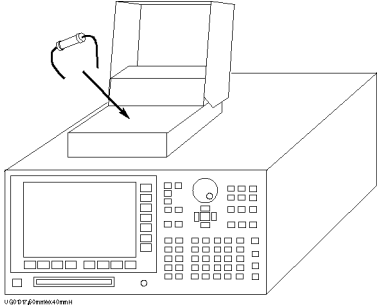
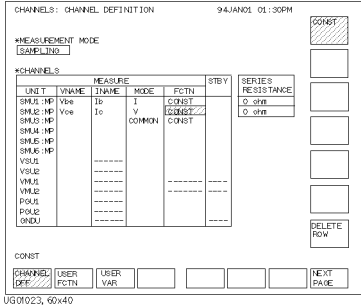
	
<p>1. Connecting your DUT to the HP 4155A/4156A. See "Connection to Device Under Test  DUT " for procedures.</p>	<p>2. Defining measurement mode and measurement units that you use to make measurement. The following tasks are described:</p> <ul style="list-style-type: none"> <li>• To Define Sampling Measurement Units.</li> <li>• To Define a User Function [see previous section]</li> <li>• To Control R-Box [see previous section]</li> </ul>

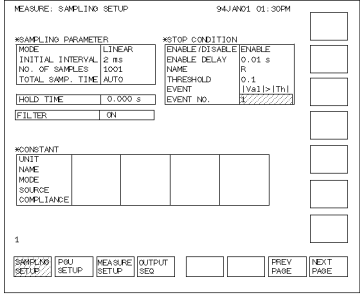
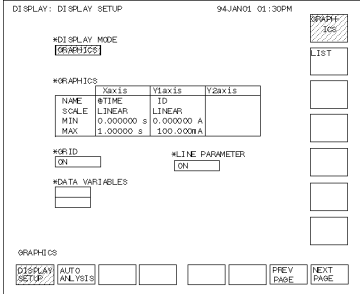
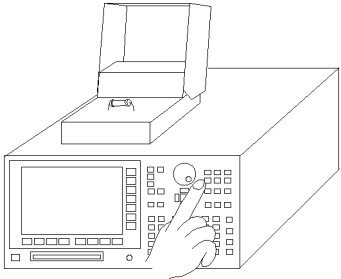
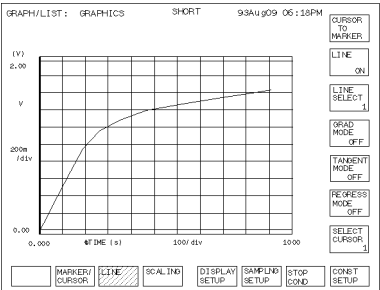

## Making a Measurement Sampling Measurements

 <p>MEASURE: SAMPLING SETUP 94JAN01 01:30PM</p> <p>*SAMPLING PARAMETER</p> <table border="1"> <tr> <td>MODE</td> <td>LINEAR</td> <td>*STOP CONDITION</td> <td>ENABLE/DISABLE/ENABLE</td> </tr> <tr> <td>INITIAL INTERVAL</td> <td>2.00 s</td> <td>ENABLE DELAY</td> <td>0.01 s</td> </tr> <tr> <td>NO. OF SAMPLES</td> <td>1000</td> <td>NAME</td> <td>IS</td> </tr> <tr> <td>TOTAL SAMP. TIME</td> <td>AUTO</td> <td>THRESHOLD</td> <td>0.1</td> </tr> <tr> <td>HOLD TIME</td> <td>0.000 s</td> <td>EVENT</td> <td>LV91(D:ITL)</td> </tr> <tr> <td>FILTER</td> <td>ON</td> <td>EVENT NO.</td> <td>1</td> </tr> </table> <p>CONSTANT</p> <table border="1"> <tr> <td>UNIT</td> <td>NAME</td> <td>MODE</td> <td>SOURCE</td> <td>COMPLIANCE</td> </tr> <tr> <td></td> <td></td> <td></td> <td></td> <td></td> </tr> </table> <p>1</p> <p>SAMPLING SETUP PGM SETUP MEASURE SETUP OUTPUT SEQ PREV PAGE NEXT PAGE</p> <p>UG101024, 60x40</p>	MODE	LINEAR	*STOP CONDITION	ENABLE/DISABLE/ENABLE	INITIAL INTERVAL	2.00 s	ENABLE DELAY	0.01 s	NO. OF SAMPLES	1000	NAME	IS	TOTAL SAMP. TIME	AUTO	THRESHOLD	0.1	HOLD TIME	0.000 s	EVENT	LV91(D:ITL)	FILTER	ON	EVENT NO.	1	UNIT	NAME	MODE	SOURCE	COMPLIANCE						 <p>DISPLAY: DISPLAY SETUP 94JAN01 01:30PM</p> <p>*DISPLAY MODE GRAPHICS LIST</p> <p>*GRAPHICS</p> <table border="1"> <tr> <td>NAME</td> <td>RTIME</td> <td>V1ax:IS</td> <td>V2ax:IS</td> </tr> <tr> <td>SCALE</td> <td>LINEAR</td> <td>LINEAR</td> <td></td> </tr> <tr> <td>MIN</td> <td>0.000000 s</td> <td>0.000000 A</td> <td></td> </tr> <tr> <td>MAX</td> <td>5.000000 s</td> <td>100.00000 A</td> <td></td> </tr> </table> <p>*GRID ON</p> <p>*LINE PARAMETER ON</p> <p>*DATA VARIABLES</p> <p>GRAPHICS</p> <p>DISPLAY SETUP AUTO ANALYSIS PREV PAGE NEXT PAGE</p> <p>UG101025, 60x40</p>	NAME	RTIME	V1ax:IS	V2ax:IS	SCALE	LINEAR	LINEAR		MIN	0.000000 s	0.000000 A		MAX	5.000000 s	100.00000 A	
MODE	LINEAR	*STOP CONDITION	ENABLE/DISABLE/ENABLE																																																
INITIAL INTERVAL	2.00 s	ENABLE DELAY	0.01 s																																																
NO. OF SAMPLES	1000	NAME	IS																																																
TOTAL SAMP. TIME	AUTO	THRESHOLD	0.1																																																
HOLD TIME	0.000 s	EVENT	LV91(D:ITL)																																																
FILTER	ON	EVENT NO.	1																																																
UNIT	NAME	MODE	SOURCE	COMPLIANCE																																															
NAME	RTIME	V1ax:IS	V2ax:IS																																																
SCALE	LINEAR	LINEAR																																																	
MIN	0.000000 s	0.000000 A																																																	
MAX	5.000000 s	100.00000 A																																																	
<p>3. Setting the source parameters of the units. The following tasks are described:</p> <ul style="list-style-type: none"> <li>To Set up Sampling Parameters</li> <li>To Set up Constant Output</li> <li>To Define Measurement Stop Conditions</li> <li>To Set up PGU Pulsed Output [see previous section]</li> </ul>	<p>4. Setting the display mode to show measurement results. The following tasks are described:</p> <ul style="list-style-type: none"> <li>To Set up Graphical Display of Measurement Results [see previous section]</li> <li>To Set up List Display of Measurement Results [see previous section]</li> </ul>																																																		
 <p>UG101026, 40x60</p>	 <p>GRAPH/LIST: GRAPHICS SHORT 93AU09 06:18PM</p> <p>CURSOR TO MARKER LINE ON LINE SELECT 1 GRAB MODE PF TANGENT MODE SF REGRESS MODE SF SELECT CURSOR 3</p> <p>MARKER/CURSOR LINE SCALING DISPLAY SETUP SAMPLING SETUP STOP COND CONST SETUP</p> <p>UG101026, 40x60</p>																																																		
<p>5. Executing the measurement. The following tasks are described:</p> <ul style="list-style-type: none"> <li>To Output Same Value Before and After Measurements [see previous section]</li> <li>To Execute or Stop Measurement [see previous section]</li> </ul>	<p>Results. For example, displayed graphically.</p>																																																		

---

## To Define Sampling Measurement Units

1. Press **Chan** key in the PAGE CONTROL key group.
2. Select **CHANNEL DEF** primary softkey.
3. In the MEASUREMENT MODE area, select **SAMPLING** secondary softkey.
4. In the VNAME column, enter a unique name for voltage variable. For example, enter **V<sub>ce</sub>** for collector-emitter voltage. If channel does neither V force nor V measurement, you can omit VNAME.
5. In the INAME column, enter a unique name for current variable. For example, enter **I<sub>c</sub>** for collector current. If channel does neither I force nor I measurement, you can omit INAME.
6. In the MODE column, select:
  - **V** secondary softkey for voltage output mode (SMU, VSU, and PGU, and grounded voltage measurement mode of VMU).
  - **I** secondary softkey for current output mode (SMU).
  - **VPULSE** secondary softkey for pulsed voltage output mode (PGU).
  - **COMMON** secondary softkey for circuit common mode (SMU and GNDU).
  - **DVOLT** secondary softkey for differential voltage measurement mode (VMU).
7. In the FCTN column, select **CONST** secondary softkey for all source units.

You can use VNAME and INAME in user function definitions or for analysis on the GRAPHICS/LIST pages. These names must be 6 or less alphanumeric characters. First character must be alphabet character.

For details about STBY and SERIES RESISTANCE fields, see “CHANNELS: CHANNEL DEFINITION page” in “Page Organization” or “Types of Operation State” in “Measurement Functions” of *HP 4155A/4156A User’s Dictionary Reference*.

Making a Measurement  
**Sampling Measurements**

**To disable a unit.**

Move the pointer to the row of the unit, then select the **DELETE ROW** secondary softkey. The settings in the row are deleted.

Example

The following figure shows an example setup to define sampling measurement units.

CHANNELS: CHANNEL DEFINITION 94JAN01 01:30PM

\*MEASUREMENT MODE  
 SAMPLING

\*CHANNELS

UNIT	VNAME	MEASURE			STBY	SERIES RESISTANCE
		INAME	MODE	FCTN		
SMU1:MP	Vbe	Ib	V	CONST		
SMU2:MP	Vce	Ic	V	CONST		0 ohm
SMU3:MP			COMMON	CONST		0 ohm
SMU4:MP						
SMU5:MP						
SMU6:MP						
VSU1		----				
VSU2		----				
VMU1				----		
VMU2				----		
PGU1						
PGU2						
GNDU						

CONST

CHANNEL DEF  
 USER FCTN  
 USER VAR  
  
  
  
  
 NEXT PAGE

U60046,10/07/00

---

## To Set up Sampling Parameters

1. Confirm that **SAMPLING** is set in the MEASUREMENT MODE field on the CHANNELS: CHANNEL DEFINITION page. If **SAMPLING** is not set, select **SAMPLING** secondary softkey in the MEASUREMENT MODE field.
2. Press **(Meas)** key in the PAGE CONTROL key group.
3. Select **SAMPLING SETUP** primary softkey.
4. In the MODE field of SAMPLING PARAMETER, select:
  - **LINEAR** secondary softkey for equally spaced sampling intervals.
  - **LOG XX** secondary softkey for logarithmically spaced sampling intervals. XX is 10, 25, or 50 sampling points per decade.
  - **THINNED-OUT** secondary softkey for reduced sampling interval of more recent samples (by thinning less recent samples).

For details about sampling mode, see “Measurement Mode” in *HP 4155A/4156A User's Dictionary Reference*.

5. In the INITIAL INTERVAL field, enter a value for the first sampling interval.
6. In the NO. OF SAMPLES field, enter the number of points at which to sample.

If you set the TOTAL SAMP. TIME to AUTO, the HP 4155A/4156A takes NO. OF SAMPLES samples, then sampling stops. If you set a value for TOTAL SAMP. TIME, see “Measurement Mode” or “Page Organization” in *HP 4155A/4156A User's Dictionary Reference*.

The following figure shows the relation between the sampling parameters and sampling measurement.

Making a Measurement  
**Sampling Measurements**

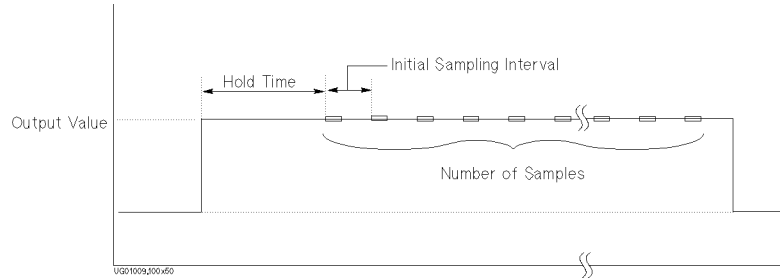

You can set a hold time by entering a number (units: seconds) in the HOLD TIME field.

Example

The following figure shows example setup of the sampling parameters.

MEASURE: SAMPLING SETUP 94JAN01 01:30PM

<b>*SAMPLING PARAMETER</b>		<b>*STOP CONDITION</b>	
MODE	LINER	ENABLE/DISABLE	ENABLE
INITIAL INTERVAL	2 ms	ENABLE DELAY	0.01 s
NO. OF SAMPLES	1001	NAME	R
TOTAL SAMP. TIME	AUTO	THRESHOLD	0.1
HOLD TIME	<input type="text"/>	EVENT	Val > Th
FILTER	<input type="text"/>	EVENT NO.	<input type="text"/>
<b>*CONSTANT</b>			
UNIT	<input type="text"/>	<input type="text"/>	<input type="text"/>
NAME	<input type="text"/>	<input type="text"/>	<input type="text"/>
MODE	<input type="text"/>	<input type="text"/>	<input type="text"/>
SOURCE	<input type="text"/>	<input type="text"/>	<input type="text"/>
COMPLIANCE	<input type="text"/>	<input type="text"/>	<input type="text"/>
1			
<input type="button" value="SAMPLING SETUP"/>	<input type="button" value="PGU SETUP"/>	<input type="button" value="MEASURE SETUP"/>	<input type="button" value="OUTPUT SEQ"/>
<input type="button" value="PREV PAGE"/>	<input type="button" value="NEXT PAGE"/>		

UGT01043,100x70

---

## To Set up Constant Output

1. Define CONST units as described in “To Define Sampling Measurement Units”.
2. Press **Meas** key in the PAGE CONTROL key group.
3. Select **SAMPLNG SETUP** primary softkey.
4. In the SOURCE field of the desired unit in the CONSTANT area, enter the desired output value.

### **To modify the UNIT, NAME, and MODE fields.**

Modify the UNIT, NAME, and MODE fields on the CHANNELS: CHANNEL DEFINITION page.

### **To set up compliance value for constant output.**

Set desired value in the COMPLIANCE field of the CONSTANT table. For details about compliance, see “Compliance” in *HP 4155A/4156A User’s Dictionary Reference*.

Making a Measurement  
**Sampling Measurements**

Example

The following example shows the constant output conditions:

MEASURE: SAMPLING SETUP 94JAN01 01:30PM

*SAMPLING PARAMETER		*STOP CONDITION	
MODE	LINEAR	ENABLE/DISABLE	ENABLE
INITIAL INTERVAL	2 ms	ENABLE DELAY	0.01 s
NO. OF SAMPLES	1001	NAME	R
TOTAL SAMP. TIME	AUTO	THRESHOLD	0.1
HOLD TIME		EVENT	Val > Th
FILTER		EVENT NO.	1

*CONSTANT			
UNIT	SMU2:HR		
NAME	V2		
MODE	V		
SOURCE	3.000V		
COMPLIANCE	100.00mA		

1.00

UGT01047,100x70

---

## To Define Measurement Stop Conditions

1. Press **Meas** key in the PAGE CONTROL key group.
2. Select **SAMPLNG SETUP** primary softkey.
3. In the ENABLE/DISABLE field of the STOP CONDITION area, select **ENABLE** secondary softkey.
4. In NAME field of STOP CONDITION area, select the secondary softkey for the desired variable name or user function name to be used for EVENT comparison.
5. In THRESHOLD field of STOP CONDITION area, enter the threshold value for the name selected in the previous step.
6. In EVENT field of STOP CONDITION area, select:
  - **Val > Th** secondary softkey to stop the sampling when the sampled value is greater than the threshold value.
  - **Val < Th** secondary softkey to stop the sampling when the sampled value is less than the threshold value.
  - **|Val| > |Th|** secondary softkey to stop the sampling when the absolute sampled value is greater than the absolute threshold value.
  - **|Val| < |Th|** secondary softkey to stop the sampling when the absolute sampled value is less than the absolute threshold value.

If you set the stop condition to DISABLE, the sampling measurement continues until:

- **Stop** key in the MEASUREMENT key group is pressed.
- Specified total sample time has elapsed.
- The HP 4155A/4156A receives HP-IB command to stop sampling.
- An emergency condition occurs on HP 4155A/4156A.
- Interlock terminal opens due to high voltage. (See “To Connect Interlock Terminal” in Chapter 2.)



Making a Measurement  
**Sampling Measurements**

You can set an EVENT NO., which specifies the sampling to stop when EVENT occurs EVENT NO. times.

Example

The following figure shows an example setup of stop condition.

MEASURE: SAMPLING SETUP 94JAN01 01:30PM

*SAMPLING PARAMETER		*STOP CONDITION	
MODE	LINEAR	ENABLE/DISABLE	ENABLE
INITIAL INTERVAL	2 ms	ENABLE DELAY	0.01 s
NO. OF SAMPLES	1001	NAME	R
TOTAL SAMP. TIME	AUTO	THRESHOLD	0.1
HOLD TIME 0.000 s		EVENT	Val > Th
FILTER ON		EVENT NO.	1
*CONSTANT			
UNIT			
NAME			
MODE			
SOURCE			
COMPLIANCE			

1

PGU SETUP  MEASURE SETUP  OUTPUT SEQ    PREV PAGE  NEXT PAGE

0010910,100270

---

## Stress Force

This section covers the tasks for stress forcing.

### **Stress Forcing with HP 4155A/4156A.**

Two types of stress can be forced by the HP 4155A/4156A:

- *dc stress*
  - Dc voltage stress can be forced from SMUs, VSUs, or PGUs.
  - Dc current stress can be forced from SMUs.
- *ac stress* (also called *pulsed stress*)
  - Ac voltage stress can be forced from PGUs.
  - Ac current stress *cannot* be forced from the HP 4155A/4156A.

### **Basic Procedure for Stress Forcing.**

The following illustrates the basic procedures for stress forcing.

## Making a Measurement Stress Force

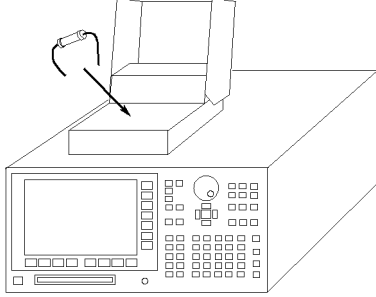
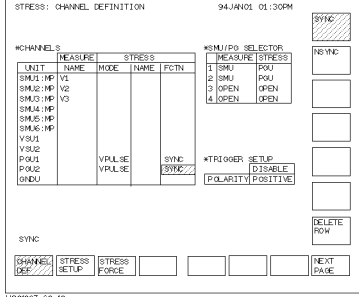
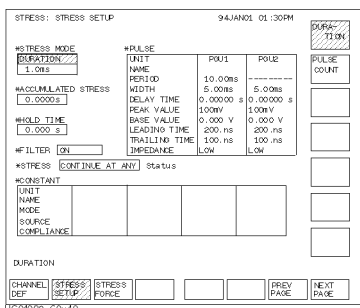
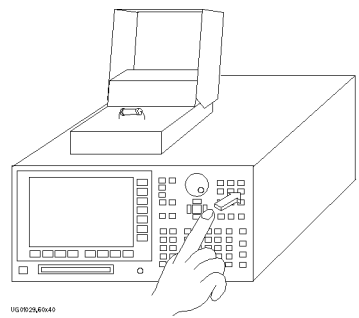
	
<p>1. Connecting your DUT to the HP 4155A/4156A. See "Connection to Device Under Test [DUT]" for procedures.</p>	<p>2. Defining the stress units and constant output units. The following tasks are described:</p> <ul style="list-style-type: none"> <li>To Set up Stress Source Channels</li> <li>To Control Selector for Switching SMU and PGU</li> </ul>
	
<p>3. Setting the stress forcing parameters and constant output value. The following tasks are described:</p> <ul style="list-style-type: none"> <li>To Set up Stress Conditions/Timings</li> <li>To Set up DC Stress</li> <li>To Set up AC [Pulse] Stress</li> </ul>	<p>4. Executing the stress forcing. The following task is described:</p> <ul style="list-style-type: none"> <li>To Force Stress</li> </ul>

---

## To Set up Stress Source Channels

1. Press **Stress** key in the PAGE CONTROL key group.
2. Select **CHANNEL DEF** primary softkey.
3. In the MODE field of desired unit in CHANNELS area, select:
  - **V** secondary softkey for dc voltage stress forcing mode (SMU, VSU, and PGU).
  - **I** secondary softkey for dc current stress forcing mode (SMU).
  - **VPULSE** secondary softkey for ac voltage stress forcing mode (PGU).
  - **COMMON** secondary softkey for circuit common (SMU and GNDU).
4. In the NAME field of desired unit in the CHANNELS area, enter the stress channel name.
5. In the FCTN field of units that will be stress force channels, select **SYNC** secondary softkey.

The stress channel name is only used for reference on the STRESS SETUP page, not on any results page. So, you can omit the name if desired.

In the FCTN column, you can set up to four units to SYNC. At least one unit must be set to SYNC in the FCTN column. The SYNC (stress force) units all start forcing stress at the same time. The NSYNC (non-stress force units) channels start forcing stress in sequence when state changes to stress force state. For this timing, see “Stress Force Sequence” in “Measurement Function” of *HP 4155A/4156A User’s Dictionary Reference*.

If the row of a unit does not have settings, the unit is not used.

### **To disable a unit.**

In the row of the unit, select the **DELETE ROW** secondary softkey. The settings in the row are deleted.

Making a Measurement

**Stress Force**

**To set up non-stress output channels.**

Perform the following procedure.

1. Perform first 3 steps described above.
2. In the FCTN field, select **NSYNC** secondary softkey.

If you use two PGUs as pulsed sources (**VPULSE**), both must be **SYNC** or both **NSYNC**.

Example

The following figure shows an example setup to set two PGUs to ac stress source.

STRESS: CHANNEL DEFINITION 94JAN01 01:30PM

*CHANNELS					*SMU/PG SELECTOR		
UNIT	MEASURE	NAME	MODE	NAME	FCTN	MEASURE	STRESS
SMU1:MP	V1					1 SMU	PGU
SMU2:MP	V2					2 SMU	PGU
SMU3:MP	V3					3 OPEN	OPEN
SMU4:MP						4 OPEN	OPEN
SMU5:MP							
SMU6:MP							
VSU1							
VSU2							
PGU1			VPULSE		SYNC		
PGU2			VPULSE		NSYNC		
GNDU							

\*TRIGGER SETUP  
 POLARITY POSITIVE

SYNC

UG101011,100x70

---

## To Set up Stress Condition/Timing

1. Press **Stress** key in the PAGE CONTROL key group.
2. Select **STRESS SETUP** primary softkey.
3. In the MODE field of the STRESS MODE area, select:
  - **DURATION** secondary softkey to specify how long to force stress.
  - **PULSE COUNT** secondary softkey to specify how many pulses to output for force stress (for ac stress only).
4. In the DURATION or PULSE COUNT field, enter the duration or pulse count. You can select **FREE RUN** secondary softkey to output stress continuously.
5. In the **STRESS Status** field, select:
  - **CONT AT ANY** secondary softkey to continue forcing the stress even if an abnormal status occurs.
  - **STOP AT ANY ABNORM** secondary softkey to stop forcing the stress when any abnormal status occurs.
  - **STOP AT COMPLIANCE** secondary softkey to stop forcing the stress only when SMU reaches its compliance setting.

**STOP AT ANY ABNORM** and **STOP AT COMPLIANCE** secondary softkeys are displayed only when specified duration is more than 10 s. If you set pulse count mode, these secondary softkeys are displayed only when  $pulse\ period \times pulse\ count$  is more than 10 s.

Stress stop function is not effective until stress has been forced for 10 s.

In the duration mode, you set time (in seconds) for stress forcing. In the pulse count mode, you set an integer to specify how many pulses to output for stress forcing.

Making a Measurement

### **Stress Force**

Abnormal status means the following:

- SMU reaches its compliance setting.
- Current of VSU exceeds  $\pm 100$  mA.
- SMU or VSU oscillates.
- A/D converter overflow occurs.
- Average current of PGU exceeds  $\pm 100$  mA.

#### **To set hold time.**

In the HOLD TIME field, set desired value. For the meaning of hold time, see “Stress Force Sequence” in “Measurement Function” of *HP 4155A/4156A User’s Dictionary Reference*.

Example

The following figure shows an example setup of stress condition.

STRESS: STRESS SETUP 94JAN01 01:30PM

*STRESS MODE		*PULSE		DURATION PULSE COUNT	
1.0ms		UNIT	PGU1		PGU2
*ACCUMULATED STRESS		NAME			
0.0000s		PERIOD	10.00ms		-----
*HOLD TIME		WIDTH	5.00ms		5.00ms
0.000 s		DELAY TIME	0.00000 s		0.00000 s
*FILTER		PEAK VALUE	100mV		100mV
ON		BASE VALUE	0.000 V		0.000 V
*STRESS		LEADING TIME	200.ns		200.ns
CONTINUE AT ANY		TRAILING TIME	100.ns		100.ns
*CONSTANT		IMPEDANCE	LOW	LOW	
UNIT					
NAME					
MODE					
SOURCE					
COMPLIANCE					

DURATION

CHANNEL DEF STRESS SETUP STRESS FORCE PREV PAGE NEXT PAGE

UG01012, 100x70

### Setting the Accumulated Stress Time

The ACCUMULATED STRESS field shows the total stress that has been forced. If necessary, you can change the value in this field. If so, the ACCUMULATED STRESS field on the STRESS: STRESS FORCE page also changes to the new value.



---

## To Set up AC (Pulse) Stress

1. Press the **Stress** key in the PAGE CONTROL key group. Confirm that the following is set on the STRESS: CHANNEL DEFINITION page for the *PGUs* that you want to set up for ac stress:
  - **VPULSE** is set in the MODE field.
  - **SYNC** is set in the FCTN field.
2. Select **STRESS SETUP** primary softkey.
3. In the PERIOD field, enter the pulse period.
4. In the WIDTH field, enter the pulse width.
5. In the DELAY TIME field, enter the delay time, which is the time from the stress start to the beginning of the pulse leading edge. See following figure.
6. In the PEAK VALUE field, enter the pulse peak value.
7. In the BASE VALUE field, enter the pulse base value.
8. In LEADING TIME field, enter the leading-edge transition time of pulse.
9. In TRAILING TIME field, enter the trailing-edge transition time of pulse.

The same period you set for PGU1 is also used for PGU2. For the other parameters, you can set different values for PGU1 and PGU2.

To set other areas of the STRESS: STRESS SETUP page, see “To Set up Stress Condition/Timing”.

### **To modify the UNIT and NAME fields.**

Modify UNIT and NAME fields on STRESS: CHANNEL DEFINITION page.

### **To set output impedance of PGU1 or PGU2.**

In the IMPEDANCE field, select:

- **LOW** secondary softkey to set output impedance to low (approximately zero).
- **50 ohm** secondary softkey to set output impedance to 50  $\Omega$ .

The following figure shows the meaning of delay time.

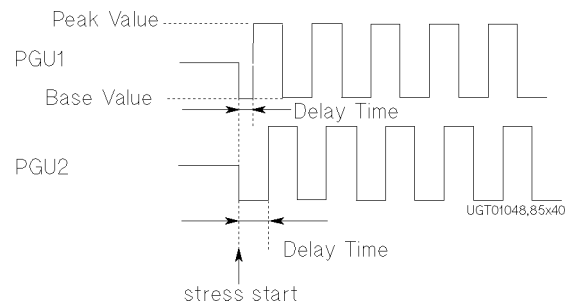

Example

The following figure shows an example to set up ac stress.

STRESS: STRESS SETUP 94JAN01 01:30PM

*STRESS MODE		*PULSE		
DURATION	1.0ms	UNIT	PGU1	PGU2
*ACCUMULATED STRESS	0.0000s	NAME		
*HOLD TIME	0.000 s	PERIOD	10.00ms	-----
*FILTER	ON	WIDTH	5.00ms	5.00ms
*STRESS	CONTINUE AT ANY	DELAY TIME	0.00000 s	0.00000 s
*CONSTANT		PEAK VALUE	100mV	100mV
UNIT	SMU1:MP	BASE VALUE	0.000 V	0.000 V
NAME	VSU	LEADING TIME	100.ns	100.ns
MODE	V	TRAILING TIME	100.ns	100.ns
SOURCE	5.00 V	IMPEDANCE	LOW	LOW
COMPLIANCE	1.0000mA			

0.000000100

CHANEL DEF **STRESS SETUP** STRESS FORCE

UG01048.85x40

---

## To Set up DC Stress

1. Press **Stress** key in the PAGE CONTROL key group. Confirm that the following is set on the STRESS: CHANNEL DEFINITION page for the units that you want to set up for dc stress:
  - V or I is set in the MODE field.
  - SYNC is set in the FCTN field.
2. Select **STRESS SETUP** primary softkey.
3. In the SOURCE field for the desired unit in the CONSTANT area, enter the desired dc stress value.
4. In the COMPLIANCE field in the CONSTANT area, enter the compliance value.

The non-stress (**NSYNC**) constant units also appear in the CONSTANT area. You can set SOURCE and COMPLIANCE values for these units the same way as you set the dc stress units.

To set other areas of the STRESS: STRESS SETUP page, see “To Set up Stress Condition/Timing”.

**To modify the UNIT, NAME, and MODE fields.**

Modify the UNIT, NAME, and MODE fields on the STRESS: CHANNEL DEFINITION page.

Example

The following figure shows an example setup to set source (SMU1) to 5.00 V and compliance (SMU1) to 1.00 mA.

STRESS: STRESS SETUP 94JAN01 01:30PM

<p>*STRESS MODE  <input type="text" value="1.0ms"/></p> <p>*ACCUMULATED STRESS  <input type="text" value="0.0000s"/></p> <p>*HOLD TIME  <input type="text" value="0.000 s"/></p> <p>*FILTER <input type="text" value="ON"/></p> <p>*STRESS <input type="text" value="CONTINUE AT ANY"/> Status</p> <p>*CONSTANT</p> <table border="1" style="width: 100%; border-collapse: collapse;"> <tr> <td style="width: 20%;">UNIT</td> <td>SMU1:MP</td> <td></td> <td></td> <td></td> </tr> <tr> <td>NAME</td> <td>VSU</td> <td></td> <td></td> <td></td> </tr> <tr> <td>MODE</td> <td>V</td> <td></td> <td></td> <td></td> </tr> <tr> <td>SOURCE</td> <td>5.00 V</td> <td></td> <td></td> <td></td> </tr> <tr> <td>COMPLIANCE</td> <td>1.0000mA</td> <td></td> <td></td> <td></td> </tr> </table> <p>0.0010000</p>	UNIT	SMU1:MP				NAME	VSU				MODE	V				SOURCE	5.00 V				COMPLIANCE	1.0000mA				<table border="1" style="width: 100%; border-collapse: collapse;"> <thead> <tr> <th style="width: 15%;">*PULSE</th> <th style="width: 15%;">UNIT</th> <th style="width: 15%;">PGU1</th> <th style="width: 15%;">PGU2</th> </tr> </thead> <tbody> <tr> <td>NAME</td> <td></td> <td></td> <td></td> </tr> <tr> <td>PERIOD</td> <td>10.00ms</td> <td>-----</td> <td></td> </tr> <tr> <td>WIDTH</td> <td>5.00ms</td> <td>5.00ms</td> <td></td> </tr> <tr> <td>DELAY TIME</td> <td>0.00000 s</td> <td>0.00000 s</td> <td></td> </tr> <tr> <td>PEAK VALUE</td> <td>100mV</td> <td>100mV</td> <td></td> </tr> <tr> <td>BASE VALUE</td> <td>0.000 V</td> <td>0.000 V</td> <td></td> </tr> <tr> <td>LEADING TIME</td> <td>100.nS</td> <td>100.nS</td> <td></td> </tr> <tr> <td>TRAILING TIME</td> <td>100.nS</td> <td>100.nS</td> <td></td> </tr> <tr> <td>IMPEDANCE</td> <td>LOW</td> <td>LOW</td> <td></td> </tr> </tbody> </table>	*PULSE	UNIT	PGU1	PGU2	NAME				PERIOD	10.00ms	-----		WIDTH	5.00ms	5.00ms		DELAY TIME	0.00000 s	0.00000 s		PEAK VALUE	100mV	100mV		BASE VALUE	0.000 V	0.000 V		LEADING TIME	100.nS	100.nS		TRAILING TIME	100.nS	100.nS		IMPEDANCE	LOW	LOW	
UNIT	SMU1:MP																																																																	
NAME	VSU																																																																	
MODE	V																																																																	
SOURCE	5.00 V																																																																	
COMPLIANCE	1.0000mA																																																																	
*PULSE	UNIT	PGU1	PGU2																																																															
NAME																																																																		
PERIOD	10.00ms	-----																																																																
WIDTH	5.00ms	5.00ms																																																																
DELAY TIME	0.00000 s	0.00000 s																																																																
PEAK VALUE	100mV	100mV																																																																
BASE VALUE	0.000 V	0.000 V																																																																
LEADING TIME	100.nS	100.nS																																																																
TRAILING TIME	100.nS	100.nS																																																																
IMPEDANCE	LOW	LOW																																																																

06000310000

---

## To Force Stress

- Press **(Stress)** key in the MEASUREMENT key group.

The STRESS area shows the specified stress duration time. Even if you set STRESS MODE to PULSE COUNT, the stress duration time is calculated and shown in seconds.

The ACCUMULATED STRESS area shows the total stress that has already been forced.

### **To change the stress time (duration mode).**

Select **CHANGE DURATON** secondary softkey, then enter desired value.

The **CHANGE DURATON** secondary softkey is displayed only if the DURATION mode is selected on the STRESS: STRESS SETUP page.

### **To change pulse count (pulse count mode).**

Select **CHANGE PLS CNT** secondary softkey, then enter desired value.

The **CHANGE PLS CNT** secondary softkey is displayed only if the PULSE COUNT mode is selected on the STRESS: STRESS SETUP page.

### **To reset STATUS value to 0 s and 0 %.**

Select **RESET STATUS** secondary softkey.

### **To reset ACCUMULATED STRESS value to 0s.**

Select **RESET ACCUM STRESS** secondary softkey.

### **To change ACCUMULATED STRESS value.**

On the STRESS: STRESS SETUP page, enter the desired value in the ACCUMULATED STRESS field.

Example

The following figure shows an example of STRESS: STRESS FORCE page.

STRESS: STRESS FORCE 94JAN01 01:30PM

*STRESS (DURATION)		CHANGE COMMENT
10.0000 s		
		CHANGE DURATON 0.0010
*STATUS		
5.0000 s	50.00 %	RESET STATUS
*ACCUMULATED STRESS		RESET ACCUM STRESS
123.4500 s		
CHANNEL DEF	STRESS SETUP	STRESS FORCE
		PREV PAGE

US200K100070

---

## To Control Selector for Switching SMU and PGU

1. Press **Stress** key in the PAGE CONTROL key group.
2. Select **CHANNEL DEF** primary softkey.
3. In the MEASURE field of the desired channel in the SMU/PG SELECTOR area, select:
  - **SMU** secondary softkey to connect SMU to DUT during measurement state.
  - **PGU** secondary softkey to connect PGU to DUT during measurement state.
  - **OPEN** secondary softkey to disconnect SMU, PGU, and DUT during measurement state.
  - **PGU OPEN** secondary softkey to disconnect PGU from DUT by semiconductor switch during measurement state.
4. In the STRESS field of the desired channel in the SMU/PG SELECTOR area, select:
  - **SMU** secondary softkey to connect SMU to DUT during stress force state.
  - **PGU** secondary softkey to connect PGU to DUT during stress force state.
  - **OPEN** secondary softkey to disconnect SMU, PGU, and DUT during stress force state.
  - **PGU OPEN** secondary softkey to disconnect PGU from DUT by semiconductor switch during stress force state.

The selector has two types of switches: relay switch and semiconductor switch.

Normally, the relay switch has three states: SMU is connected to DUT, PGU is connected to DUT, and neither is connected to DUT. The semiconductor switch, which is in the PGU line, is used for high-speed switching.

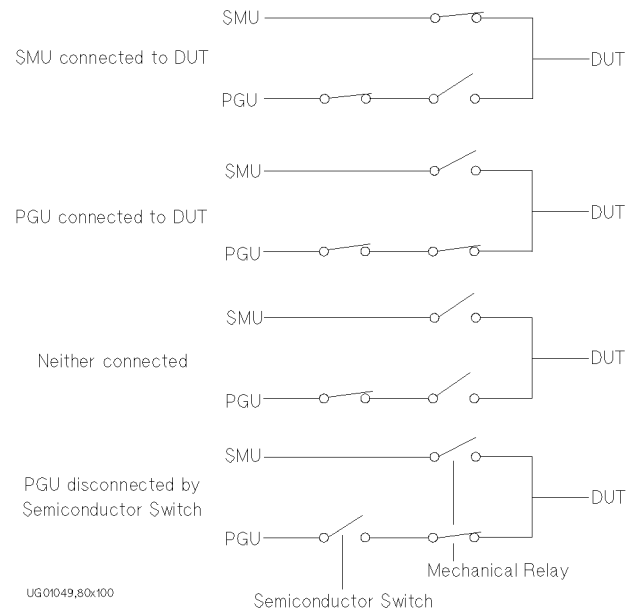

Example

Following shows an example setup that connects two SMUs to DUT during measurement state, and connects two PGUs to DUT during stress force state.

STRESS: CHANNEL DEFINITION 94JAN01 01:30PM

*CHANNELS					*SMU/PG SELECTOR	
UNIT	MEASURE	MODE	NAME	FCTN	MEASURE	STRESS
SMU1:MP	V1				1 SMU	PGU
SMU2:MP	V2				2 SMU	PGU
SMU3:MP	V3				3 OPEN	OPEN
SMU4:MP					4 OPEN	OPEN
SMU5:MP						
SMU6:MP						
VSU1						
VSU2						
PGU1		VPULSE		SYNC		
PGU2		VPULSE		SYNC		
GNDU						

\*TRIGGER SETUP  
 DISABLE  
 POLARITY POSITIVE

PGU B

CHANNEL DEF STRESS SETUP STRESS FORCE NEXT PAGE

UG01046,106x70



Making a Measurement  
**Stress Force**

---

**————** Analyzing Measurement  
Results

---

## Analyzing Measurement Results

HP 4155A/4156A can analyze measurement results of the GRAPH/LIST page group by using lines, markers, and cursors. You can perform manual or automatic analysis.

For automatic analysis function, you set up the DISPLAY: ANALYSIS SETUP page before starting measurements. Then, after the measurements are performed, the lines and markers are positioned automatically according to the setup.

The information about these functions is organized into the following two sections:

- Manual Analysis
- Automatic Analysis

For details about line modes and specifying points, refer to “Data Variable and Analysis Function” in *HP 4155A/4156A User’s Dictionary Reference*. Also, see “GRAPH/LIST Page Group” in *HP 4155A/4156A User’s Dictionary Reference*.

---

## Manual Analysis

You can position lines, markers, and cursors by using front-panel keys, rotary knob, and softkeys.

This section covers the following manual analysis tasks:

- To specify a measurement point on curve
- To specify between measurement points on curve
- To display or move cursor
- To adjust display range to measurement curve automatically
- To zoom the display range
- To center display at cursor location
- To draw line through two specified points
- To draw line through specified point with specified gradient
- To draw tangent to specified point of measurement curve
- To draw regression line for specified region
- To display and select a line
- To display grid on the graph
- To change data variable on Graph
- To change range of X or Y axis scale
- To change variable assigned to X, Y1, or Y2 axis
- To overlay an internal memory measurement curve onto plotting area
- To scroll the LIST page
- To display or move marker on LIST page
- To change variables of LIST page

---

## To Specify a Measurement Point on Curve

1. Select **MARKER/CURSOR** primary softkey.
2. Set **MARKER** secondary softkey to **ON**. Marker and marker coordinates are displayed. Selecting **MARKER** secondary softkey toggles between **ON** and **OFF**.
3. (if both Y1 and Y2 axis are set up) Select the desired marker (axis) by using **AXIS** primary softkey. The selected marker is highlighted. Selecting **AXIS** primary softkey toggles between **Y1** and **Y2**.
4. Rotate the rotary knob to move the marker to desired measurement point.

If both Y1 and Y2 axis are set up, a circle marker (o) is displayed on measurement curve of Y1 axis, and an asterisk marker (\*) is displayed on measurement curve of Y2 axis.

The **MARKER** coordinate fields indicate the location of markers. The first, second, and third fields are X, Y1, and Y2 coordinates, respectively. X and Y1 indicate location of marker on Y1 curve. X and Y2 indicate location of marker on Y2 curve.

### **To turn off markers.**

Set **MARKER** secondary softkey to **OFF**.

### **To move marker to maximum or minimum value of measurement curve.**

Select **MARKER MIN/MAX** secondary softkey. The marker searches for minimum or maximum value in measurement order from the present location every time you select the **MARKER MIN/MAX** secondary softkey.

### **To move marker to next VAR2 step or append curve.**

Select **MARKER SKIP** secondary softkey. Marker moves to next VAR2 step curve or next append curve every time you select **MARKER SKIP** secondary softkey.

### **To move marker fast.**

Press **(Fast)** front-panel key of the **MARKER/CURSOR** key group while rotating rotary knob.

Example

The following figure shows an example to move marker to desired measurement point and to set the Y1 axis marker to active.

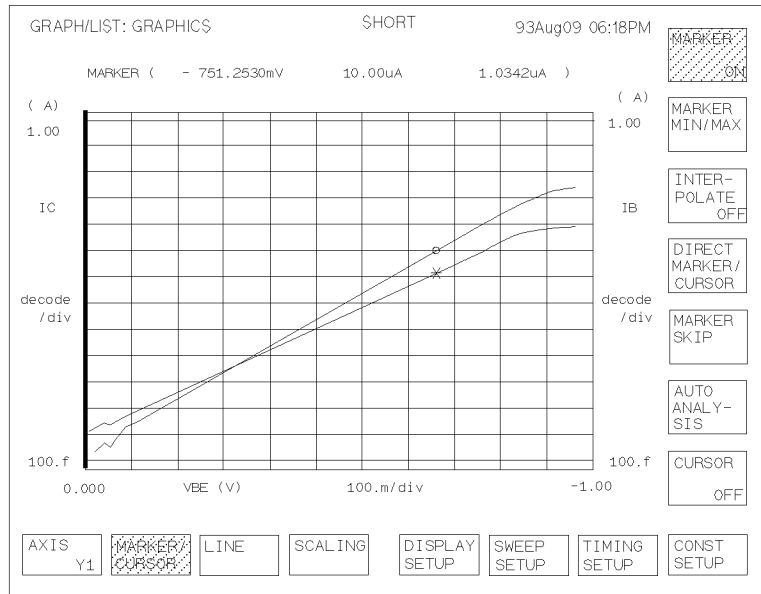

---

## To Specify between Measurement Points on Curve

1. Select **MARKER/CURSOR** primary softkey.
2. Set **MARKER** secondary softkey to **ON**. Marker and marker coordinates are displayed. Selecting **MARKER** toggles between **ON** and **OFF**.
3. (if both Y1 and Y2 axis are set up) Select the desired marker (axis) by using **AXIS** primary softkey. The selected marker is highlighted. Selecting **AXIS** primary softkey toggles between Y1 and Y2.
4. Set **INTERPOLATE** secondary softkey to **ON**. Selecting **INTERPOLATE** secondary softkey toggles between **ON** and **OFF**.
5. Rotate rotary knob to move the marker to desired measurement point.

If both Y1 and Y2 axis are set up, a circle marker (o) is displayed on measurement curve of Y1 axis, and an asterisk marker (\*) is displayed on measurement curve of Y2 axis.

The **MARKER** coordinate fields indicate the location of markers. The first, second, and third fields are X, Y1, and Y2 coordinates, respectively. X and Y1 indicate location of marker on Y1 curve. X and Y2 indicate location of marker on Y2 curve.

### **To turn off markers.**

Set the **MARKER** secondary softkey to **OFF**.

### **To move marker to maximum or minimum value of measurement curve.**

Select **MARKER MIN/MAX** secondary softkey. The marker searches for minimum or maximum value in measurement order from the present location every time you select the **MARKER MIN/MAX** secondary softkey.

### **To move marker to next VAR2 step or append curve.**

Select **MARKER SKIP** secondary softkey. Marker moves to next VAR2 step curve or next append curve every time you select **MARKER SKIP**.

**To move marker fast.**

Press **[Fast]** front-panel key of the MARKER/CURSOR key group while rotating rotary knob.

Example

The following figure shows an example to move marker to points between measurement points by setting **INTERPOLATE** softkey to ON.

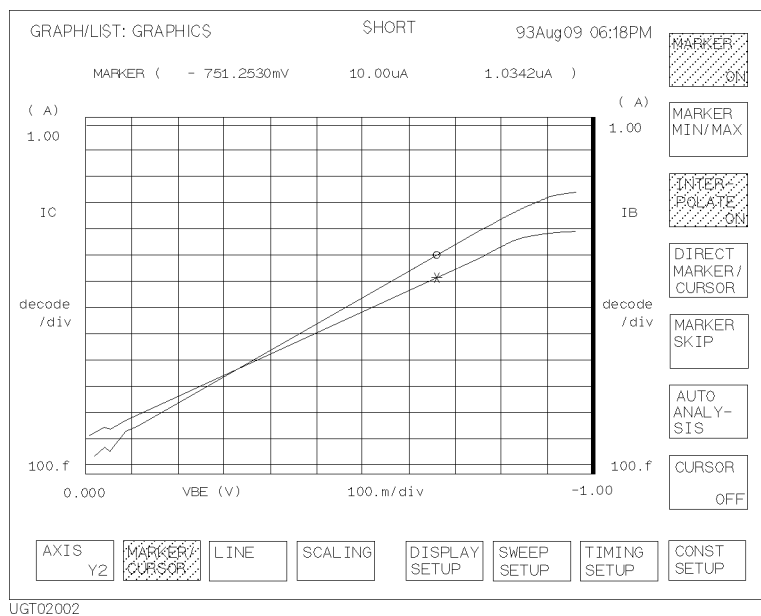

UGT02002



## To Display or Move Cursor

1. Select **MARKER/CURS** primary softkey.
2. Set **CURS** secondary softkey to **SHORT** or **LONG**. Short or long cursor and cursor coordinates are displayed. Selecting **CURS** secondary softkey toggles as follows:

**OFF → SHORT → LONG → OFF**

3. Move the cursor by using arrow keys of the **MARKER/CURS** key group.

The **CURS** coordinate fields indicate the location of cursor. The first, second, and third fields are X, Y1, and Y2 coordinates, respectively.

### **To move cursor diagonally.**

Press two adjacent arrow keys of the **MARKER/CURS** key group simultaneously.

### **To turn off cursor.**

Set **CURS** secondary softkey to **OFF**.

### **To move cursor fast.**

Press arrow keys and **(Fast)** key of the **MARKER/CURS** key group simultaneously.

Example

The following figure shows an example to display a short cursor.

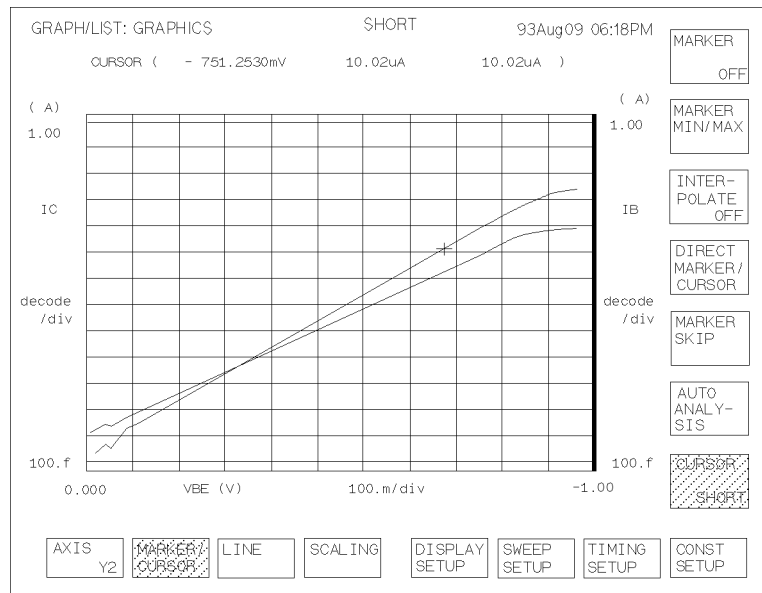

UGT02003

---

## To Adjust Display Range to Measurement Curve Automatically

1. Select **SCALING** primary softkey.
2. (if both Y1 and Y2 axis are set up) Select desired measurement curve by using **AXIS** primary softkey.
3. Select **AUTO SCALING** secondary softkey. Scale is changed automatically to fit the selected measurement curve.

When you set VAR2 parameter, or when you perform append measurement, the scale is changed so that all measurement curves can be displayed.

### **To cancel auto scaling.**

Select **CANCEL SCALING** secondary softkey.

---

## To Zoom the Display Range

1. Position the cursor at the center of area that you want to zoom. (For details about displaying and moving cursor, see “To Display or Move Cursor”.)
2. Select **SCALING** primary softkey.
3. Select:
  - **ZOOM IN** secondary softkey to decrease the display range to half the present range.
  - **ZOOM OUT** secondary softkey to increase the display range to double the present range.

The display range is increased or decreased, and cursor is moved to the center of the plotting area.

If no cursor is displayed before step 3, performing step 3 displays a long cursor at the center of the plotting area, then zoom is performed.

### **To return to original scaling.**

Select **CANCEL SCALING** secondary softkey.

---

## To Center Display at Cursor Location

1. Position cursor at the point where you want to center the plotting area.  
(For details about displaying and moving cursor, see “To Display or Move Cursor”.)
2. Select **SCALING** primary softkey.
3. (if both Y1 and Y2 axis are set up) Select desired measurement curve by using **AXIS** primary softkey.
4. Select **CENTER AT CURSOR** secondary softkey. The plotting area is centered around the cursor location.

If no cursor is displayed before step 4, performing step 4 displays a long cursor at the center of the plotting area.

**To return plotting area to original position.**

Select **CANCEL SCALING** secondary softkey.

---

## To Draw Line through Two Specified Points

1. Select **LINE** primary softkey.
2. Set **LINE SELECT** softkey to 1 or 2. Selecting this softkey toggles the setting.
3. Set **LINE** secondary softkey to **ON**. A line and two cursors are displayed. Selecting **LINE** secondary softkey toggles as follows:

**OFF → ON → OFF**

The line mode should be normal. So (**GRAD MODE**, **TANGENT MODE**, or **REGRESS MODE**) softkeys should not be highlighted. If one of these softkeys is highlighted, turn off by pressing the softkey.

4. Move cursors to desired locations by using arrow keys of the **MARKER/CURSOR** key group. To select the cursor you want to move, use the **SELECT CURSOR** secondary softkey.

If it seems that only one cursor is displayed, the cursors are at the same location.

When lines are displayed and when **ON** is set in the **LINE PARAMETER** field on the **DISPLAY: DISPLAY SETUP** page, their X and Y intercepts and gradients are also displayed in the plotting area.

### **To turn off the line intercept and gradient display.**

Select **DISPLAY SETUP** primary softkey, then set **LINE PRMTRS** secondary softkey to **OFF**.

### **To turn off the data variable display area.**

Use the following procedure:

1. Select **DISPLAY SETUP** primary softkey.
2. Set **DATA VAR** secondary softkey to **OFF**.

### **To move the selected cursor to the selected marker position.**

Select **CURSOR TO MARKER** secondary softkey.

Analyzing Measurement Results  
**Manual Analysis**

Example

The following figure shows an example to draw a line through two specified points.

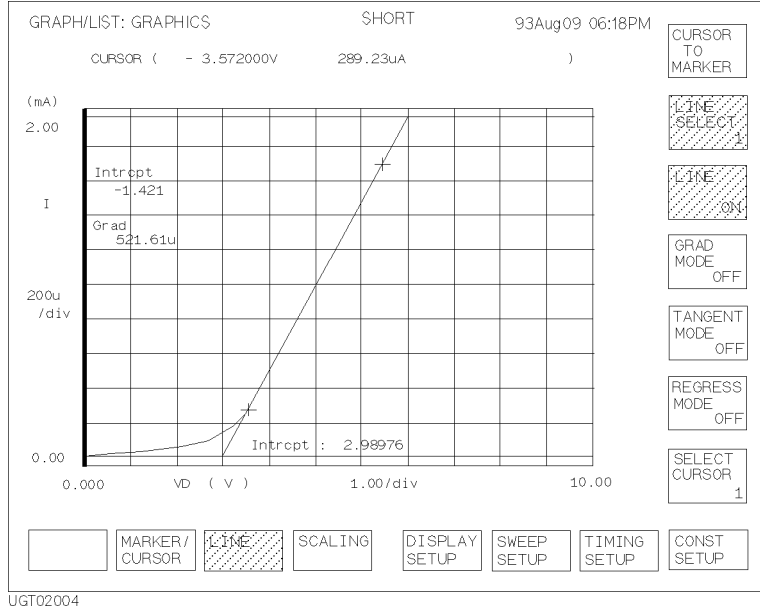

---

## To Draw Line through Specified Point with Specified Gradient

1. Select **LINE** primary softkey.
2. Set **LINE SELECT** softkey to 1 or 2. Selecting this softkey toggles the setting.
3. Set **LINE** secondary softkey to **ON**. A line and two cursors are displayed. Selecting **LINE** secondary softkey toggles as follows:  

OFF → ON → OFF
4. Select **GRAD MODE** secondary softkey if it is not highlighted. Softkey becomes highlighted. One cursor disappears (if there are two cursors in the plotting area before this step). Selecting **GRAD MODE** secondary softkey toggles between highlighted and not highlighted.
5. Move the cursor to desired location by using arrow keys of the **MARKER/CURSOR** key group.
6. Select **GRAD VALUE** secondary softkey, then enter gradient value. The line goes through the cursor with specified gradient.

When lines are displayed and when **ON** is set in the **LINE PARAMETER** field on the **DISPLAY: DISPLAY SETUP** page, the X and Y intercepts and gradients of selected line are also displayed in the plotting area.

### **To turn off the line intercept and gradient display.**

Select **DISPLAY SETUP** primary softkey, then set **LINE PRMTRS** secondary softkey to **OFF**.

### **To turn off the data variable display area.**

Use the following procedure:

1. Select **DISPLAY SETUP** primary softkey.
2. Set **DATA VAR** secondary softkey to **OFF**.

### **To move the selected cursor to the selected marker position.**

Select **CURSOR TO MARKER** secondary softkey.



Analyzing Measurement Results  
**Manual Analysis**

Example

The following figure shows an example to draw a line through specified point with specified gradient.

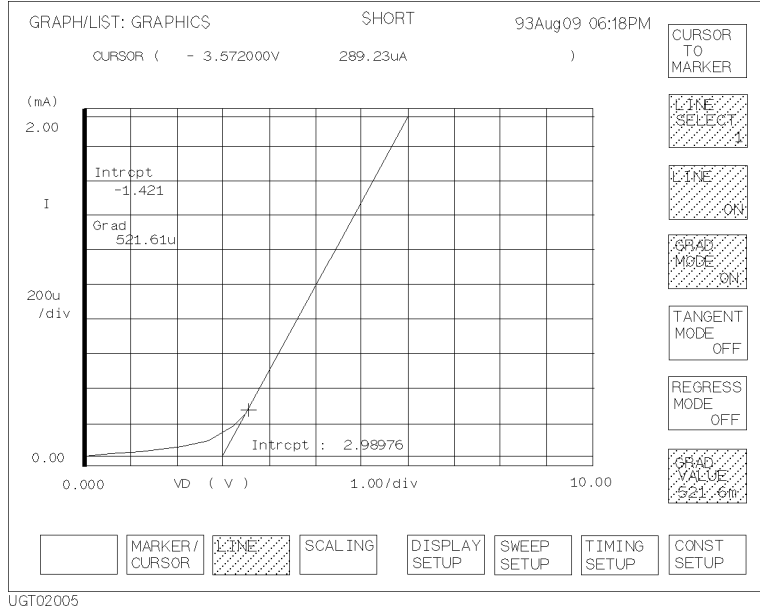

---

## To Draw Tangent to Specified Point of Measurement Curve

1. Press **LINE** primary softkey.
2. Set **LINE SELECT** softkey to 1 or 2. Selecting this softkey toggles the setting.
3. Set **LINE** secondary softkey to **ON**. A line and two cursors are displayed. Selecting the **LINE** secondary softkey toggles as follows:  
**OFF → ON → OFF**
4. Select **TANGENT MODE** secondary softkey if it is not highlighted. Softkey becomes highlighted. The cursors disappear and marker appears. Selecting **TANGENT MODE** toggles between highlighted and not highlighted.
5. Move marker to the desired measurement point by rotating rotary knob.

When lines are displayed and when **ON** is set in the **LINE PARAMETER** field on the **DISPLAY: DISPLAY SETUP** page, the X and Y intercepts and gradients of selected line are also displayed in the plotting area.

### **To move marker to next VAR2 or next append curve.**

Select **MARKER SKIP** secondary softkey. Marker moves to next VAR2 step curve or next append curve every time you press **MARKER SKIP**.

### **To turn off the line intercept and gradient display.**

Select **DISPLAY SETUP** primary softkey, then set **LINE PRMTRS** secondary softkey to **OFF**.

### **To turn off the data variable display area.**

Use the following procedure:

1. Select **DISPLAY SETUP** primary softkey.
2. Set **DATA VAR** secondary softkey to **OFF**.

### **To move marker between two adjacent measurement points.**

See "To Specify between Measurement Points on Curve".

Analyzing Measurement Results  
**Manual Analysis**

Example

The following figure shows an example to draw a tangent to a specified measurement point.

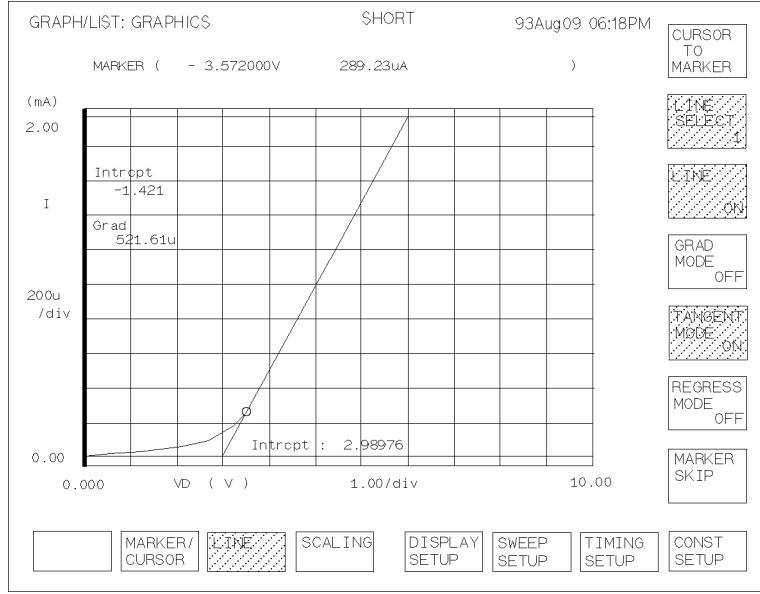

---

## To Draw Regression Line for Specified Region

1. Select **MARKER/CURSOR** primary softkey, then set the **MARKER** secondary softkey to **ON**.
2. Select the desired axis for regression calculation by selecting **AXIS** primary softkey (if both Y1 and Y2 axis are set up). Then, if necessary, move marker to desired measurement curve by selecting **MARKER SKIP** secondary softkey.
3. Select **LINE** primary softkey.
4. Set **LINE SELECT** softkey to 1 or 2. Selecting this softkey toggles the setting.
5. Set **LINE** secondary softkey to **ON**. A line and two cursors are displayed. Selecting **LINE** secondary softkey toggles as follows:  
**OFF → ON → OFF**
6. Select **REGRESS MODE** secondary softkey if it is not highlighted. Softkey becomes highlighted. Selecting **REGRESS MODE** secondary softkey toggles between highlighted and not highlighted.
7. Move cursors to specify range of regression calculation. (Use arrow keys of the **MARKER/CURSOR** key group to move cursors to desired location.)

To select the cursor you want to move, use the **SELECT CURSOR** secondary softkey.

The range used for calculating the regression line is defined by the position of the two cursors as shown in the following figure.

### Manual Analysis

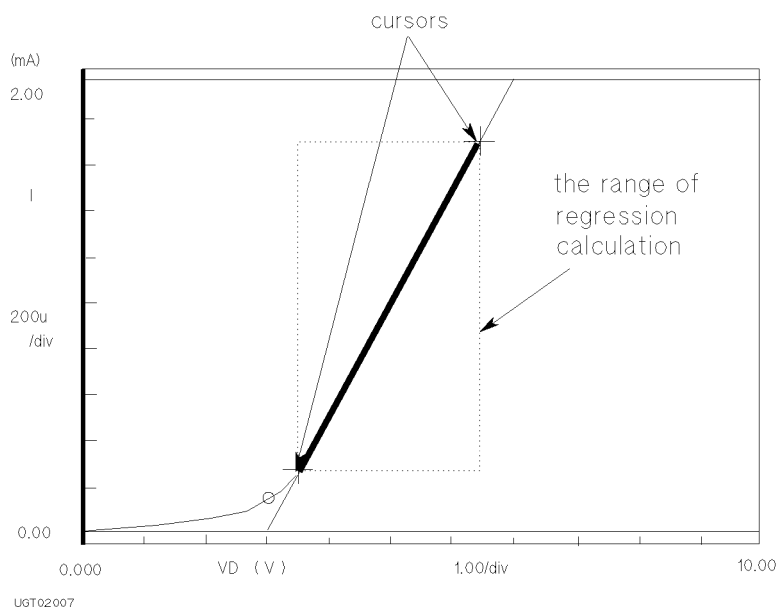

If it seems that only one cursor is displayed, the cursors are at the same location.

When regression lines are displayed and when **ON** is set in the **LINE PARAMETER** field on the **DISPLAY: DISPLAY SETUP** page, the X and Y intercepts and gradient of selected line are also displayed in the plotting area.

#### **To turn off the line intercept and gradient display.**

Select **DISPLAY SETUP** primary softkey, then set **LINE PRMTRS** secondary softkey to **OFF**.

#### **To turn off the data variable display area.**

Use the following procedure:

1. Select **DISPLAY SETUP** primary softkey.
2. Set **DATA VAR** secondary softkey to **OFF**.

#### **To move selected cursor to the selected marker position.**

Select **CURSOR TO MARKER** secondary softkey.

Example

The following figure shows an example to draw a regression line for the specified region.

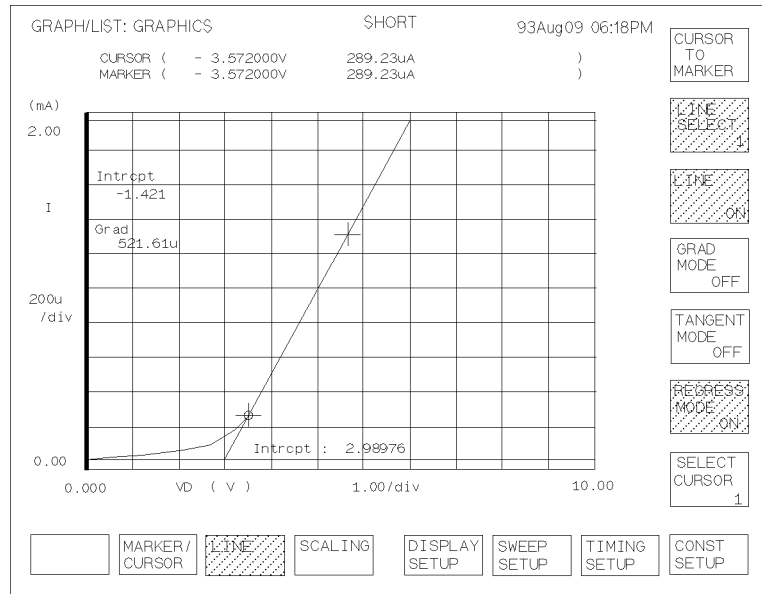

---

## To Display and Select a Line

1. Select **LINE** primary softkey.
2. Set **LINE SELECT** softkey to 1 or 2. Selecting this softkey toggles the setting.
3. Set **LINE** secondary softkey to **ON**. Selected line and two cursors are displayed. Selecting the **LINE** secondary softkey toggles as follows:

**OFF → ON → OFF**

### **To select line to analyze.**

Set **LINE SELECT** secondary softkey to desired line (1 or 2). Selected line is highlighted.

Selecting **LINE SELECT** secondary softkey toggles as follows:

**1 → 2 → NONE → 1**

The following are independent for each line. So, changing the active line also changes the following:

- locations of marker and cursors
- X and Y intercepts and gradient

---

## To Display Grid on the Graph

1. Select **DISPLAY SETUP** primary softkey.
2. Set **GRID** secondary softkey to **ON**. Grid is displayed. Selecting **GRID** secondary softkey toggles between **ON** and **OFF**.

### **To turn off grid.**

Set **GRID** secondary softkey to **OFF**.



**Manual Analysis**

---

## To Change Data Variable on Graph

1. Select **DISPLAY SETUP** primary softkey.
2. Select **RE-SETUP GRAPH** secondary softkey.
3. Move the pointer to desired data variable field by using the arrow keys, then select secondary softkey to enter the desired variable name.
4. Select **EXIT** primary softkey to exit the RE-SETUP GRAPH mode.

**To exit without changing data variable.**

Select **CANCEL** primary softkey.

Example

The following figure shows an example setup to change the data variable to be displayed.

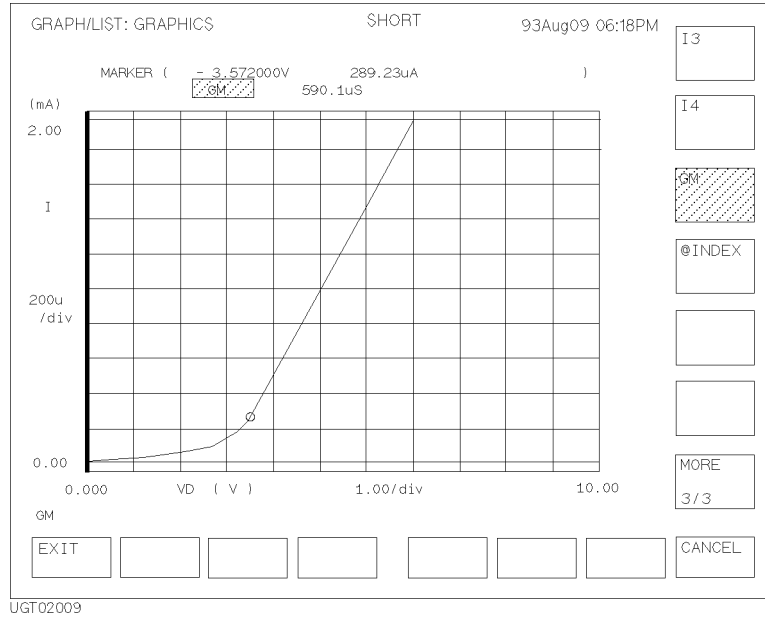

---

## To Change Range of X or Y Axis Scale

1. Select **DISPLAY SETUP** primary softkey.
2. Select **RE-SETUP GRAPH** secondary softkey.
3. Move pointer to maximum or minimum value field of X or Y axis scale by using the arrow keys, then edit the setup value by using ENTRY keys or rotary knob.
4. Select **EXIT** primary softkey to exit RE-SETUP GRAPH mode.

### To exit without changing range of X or Y axis scale.

Select **CANCEL** primary softkey.

Example

The following figure shows an example setup to change maximum value of Y1 axis.

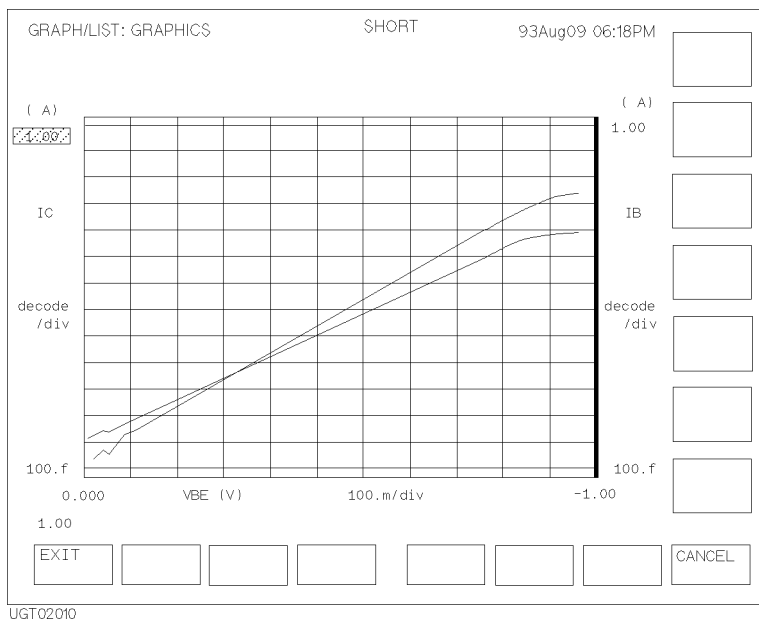

**Manual Analysis**

**To Change Variable Assigned to X, Y1, or Y2 Axis**

1. Select **DISPLAY SETUP** primary softkey.
2. Select **RE-SETUP GRAPH** secondary softkey.
3. Move pointer to variable field of X, Y1, or Y2 axis by using arrow keys, then select secondary softkey to set the desired variable.
4. Select **EXIT** primary softkey to exit RE-SETUP GRAPH mode.

**To exit without changing variable assigned to X, Y1, or Y2 axis.**

Select **CANCEL** primary softkey.

Example

The following figure shows an example setup to change the variable that is assigned to Y1 axis.

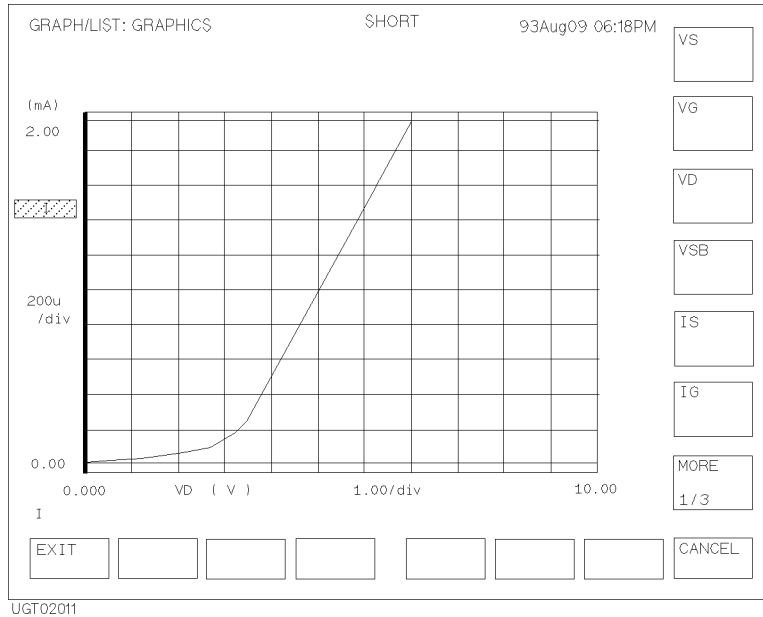

---

## To Overlay an Internal Memory Measurement Curve onto Plotting Area

This section explains how to overlay a measurement curve (that was stored into an internal memory) onto plotting area. To store a measurement curve into an internal memory, refer to “To Store Setup or Result Data into Internal Memory” in Chapter 5.

1. Select **DISPLAY SETUP** primary softkey.
2. Set **OVERLAY PLANE** secondary softkey to the desired memory number. Selected measurement curve is overlaid onto plotting area. Selecting **OVERLAY PLANE** secondary softkey toggles as follows:

OFF → 1 → 2 → 3 → 4 → OFF

### **To display information of overlay measurement curve.**

Select **SHOW OVERLAY INFO** secondary softkey. The following information of overlay measurement curve overwrites the information of the present curve.

- axis names and axis scales
- cursor and marker coordinates
- data variables

To display information of original curve again, select the **EXIT** primary softkey.

### **To change the present scale to the same scale as overlay curve.**

Select **SCALE TO OVERLAY** secondary softkey.

To return to the original scale, you need to select **SCALING** primary softkey, then select **CANCEL SCALING** secondary softkey.

Analyzing Measurement Results

**Manual Analysis**

Example

The following figure shows an example to overlay a measurement curve (that is stored in internal memory 1) onto the presently displayed measurement curve.

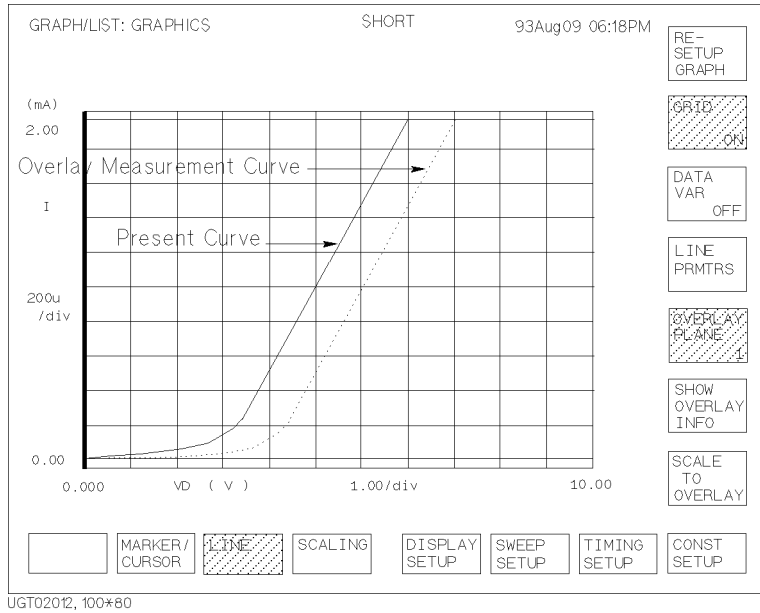

---

## To Scroll the LIST Page

- Press an arrow key of the MARKER/CURSOR key group. List scrolls in direction of selected arrow.

List can be scrolled even while performing measurements.

When marker is displayed, marker does not move during scrolling.

### **To scroll list fast.**

Press **(Fast)** key of the MARKER/CURSOR key group while pressing an arrow key of the MARKER/CURSOR key group.

---

## To Display or Move Marker on LIST Page

1. Select **MARKER** primary softkey.
2. Set **MARKER** secondary softkey to **ON**. The marker is displayed. Selecting **MARKER** secondary softkey toggles between **ON** and **OFF**.
3. Rotate rotary knob to move the marker to desired measurement point.

**To turn off marker.**

Set **MARKER** secondary softkey to **OFF**.

**To move marker to next VAR2 step.**

Select **MARKER SKIP** secondary softkey. Marker moves to next VAR2 step data or next append data every time you select **MARKER SKIP** secondary softkey.

**To move marker to next append data.**

Select **NEXT APPEND** secondary softkey. Marker moves to next append data every time you select **NEXT APPEND** secondary softkey.

Example

The following figure shows an example to display marker.

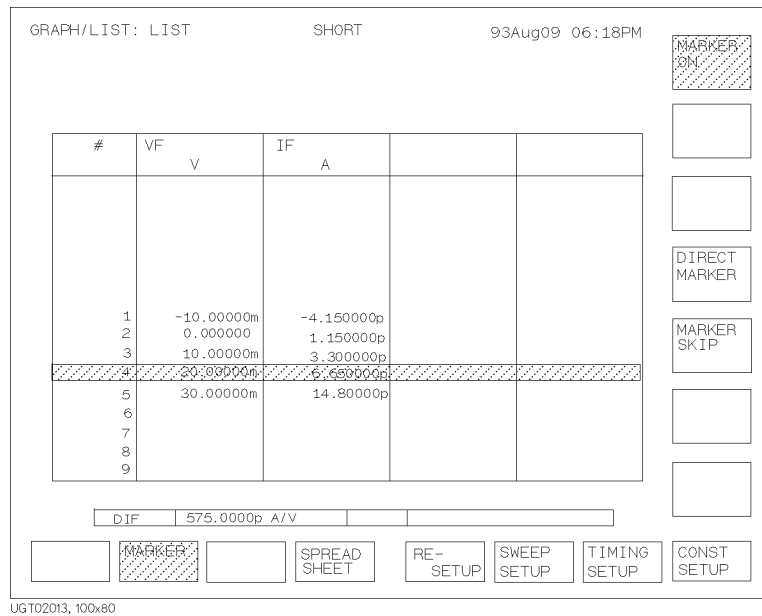



**Manual Analysis**

**To Change Variables of LIST page**

1. Select **RE-SETUP** primary softkey.
2. Move pointer to desired column variable or data variable field by using arrow keys, then select secondary softkey of desired variable.
3. Select **EXIT** primary softkey to exit RE-SETUP LIST mode.

**To exit without changing LIST variables.**

Select **CANCEL** primary softkey.

Example

The following figure shows an example to change the LIST variables.

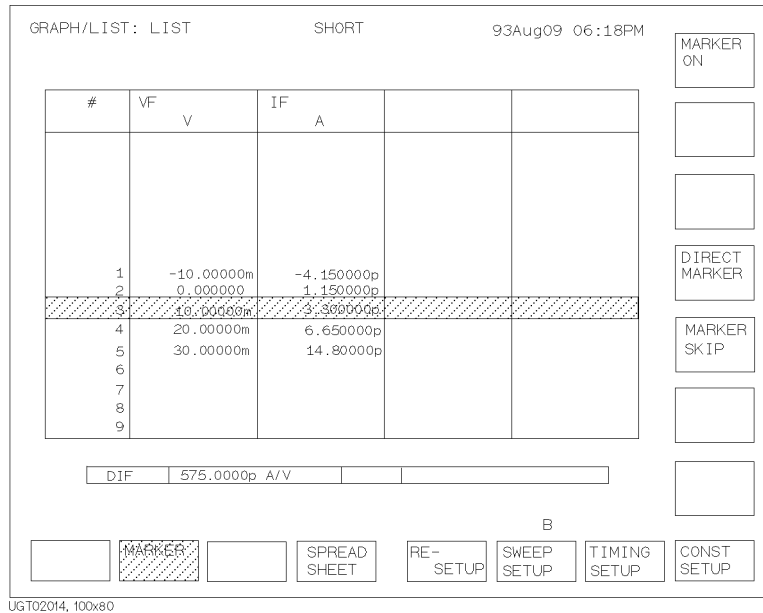

---

## Automatic Analysis

You set up automatic analysis before the measurement by using the DISPLAY: ANALYSIS SETUP page. Then, after measurement is performed, the marker and lines are automatically positioned according to automatic analysis setup.

This section covers the following automatic analysis tasks:

- To draw line by specifying two points
- To draw line by specifying gradient and one point
- To draw tangent to specified measurement point
- To draw regression line by specifying two points
- To display marker at specified point

---

## To Draw Line by Specifying Two Points

1. Press **Display** front-panel key.
2. Confirm that **ON** is set on the **LINE** *secondary* softkey on the GRAPH/LIST: GRAPHICS page.
3. Select **ANLYSIS SETUP** primary softkey. The DISPLAY: ANALYSIS SETUP page is displayed.
4. In field (1), select **NORMAL** secondary softkey.
5. In field (2), select secondary softkey to specify desired axis.
6. In field (3), select:
  - **BY X-Y COORDINATE** secondary softkey to specify a point by X-Y coordinate mode. (Go to step 6.)
  - **BY DATA CONDITION** secondary softkey to specify a point by data condition mode. (Go to step 7.)
7. If you selected **BY X-Y COORDINATE** secondary softkey:
  - a. In the X field, enter desired expression to specify X coordinate.
  - b. In the Y field, enter desired expression to specify Y coordinate.
  - c. Go to step 8.
8. If you selected **BY DATA CONDITION** secondary softkey:
  - a. In field (4), select secondary softkey to set desired data variable name.
  - b. In field (5), enter desired expression.
  - c. In field (6), select:
    - **AFTER** secondary softkey if you want to set a search start condition for finding specified point.
    - **DISABLE** secondary softkey to disable (clear) the **AFTER** settings.
  - d. If you selected **AFTER**, select secondary softkey to enter desired data variable in field (7).
  - e. If you selected **AFTER**, enter desired expression in field (8).
9. Specify the other point by step 5, then step 6 or 7.

Data condition mode specifies a point related to the measurement curve. So, if no measurement data satisfy the specified condition, the nearest measurement point is used.

For the meaning of expression that you can enter in step 6 or 7, see “Expression” in “Data Variable and Analysis Function” in *HP 4155A/4156A User’s Dictionary Reference*.

**To specify a point between two measurement points.**

Set Interpolate field to ON.

**To disable (clear) the settings.**

Move the pointer to field (1), then select **DISABLE** secondary softkey. Setup fields disappear.

Example

The following figure shows an example setup to automatically draw a line through two specified points. One point is specified by X-Y coordinate mode and other point is specified by data condition mode.

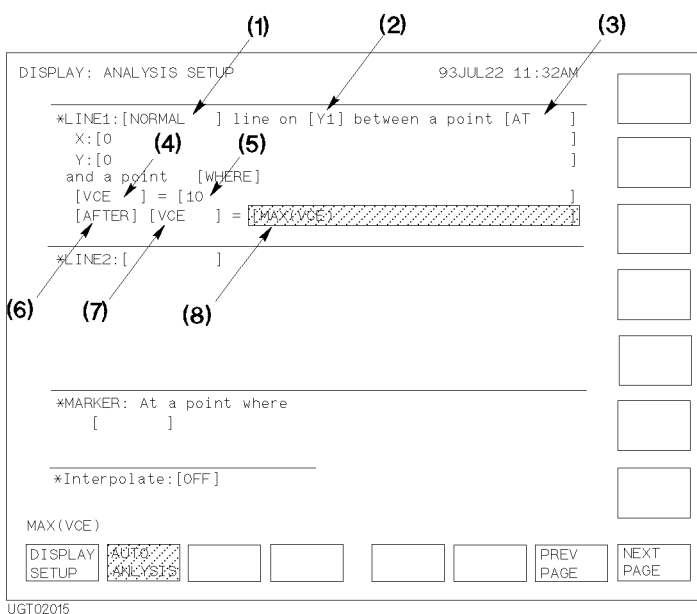

---

## To Draw Line by Specifying Gradient and One Point

1. Press **Display** front-panel key.
2. Confirm that **ON** is set on the **LINE** *secondary* softkey on the GRAPH/LIST: GRAPHICS page.
3. Select **ANLYSIS SETUP** primary softkey. The DISPLAY: ANALYSIS SETUP page is displayed.
4. In field (1), select **GRAD** secondary softkey.
5. In field (2), select secondary softkey to specify desired axis.
6. In field (3), select:
  - **BY X-Y COORDINATE** secondary softkey to specify a point by X-Y coordinate mode. (Go to step 6.)
  - **BY DATA CONDITION** secondary softkey to specify a point by data condition mode. (Go to step 7.)
7. If you selected **BY X-Y COORDINATE** secondary softkey:
  - a. In the X field, enter desired expression to specify X coordinate.
  - b. In the Y field, enter desired expression to specify Y coordinate.
  - c. Go to step 8.
8. If you selected **BY DATA CONDITION** secondary softkey:
  - a. In field (4), select secondary softkey to set desired data variable name.
  - b. In field (5), enter desired expression.
  - c. In field (6), select:
    - **AFTER** secondary softkey if you want to set a search start condition for finding specified point.
    - **DISABLE** secondary softkey to disable (clear) the **AFTER** settings.
  - d. If you selected **AFTER**, select secondary softkey to enter desired data variable in field (7).
  - e. If you selected **AFTER**, enter desired expression in field (8).
9. In the Gradient field, enter gradient expression.

Data condition mode specifies a point related to the measurement curve. So, if no measurement data satisfy the specified condition, the nearest measurement point is used.

For the meaning of expression that you can enter in step 6 or 7, see “Expression” in “Data Variable and Analysis Function” in *HP 4155A/4156A User’s Dictionary Reference*.

**To specify a point between two measurement points.**

Set Interpolate field to ON.

**To disable (clear) the settings.**

Move the pointer to field (1), then select **DISABLE** secondary softkey. Setup fields disappear.

Example

The following figure shows an example setup to automatically draw a line through the specified point with the specified gradient.

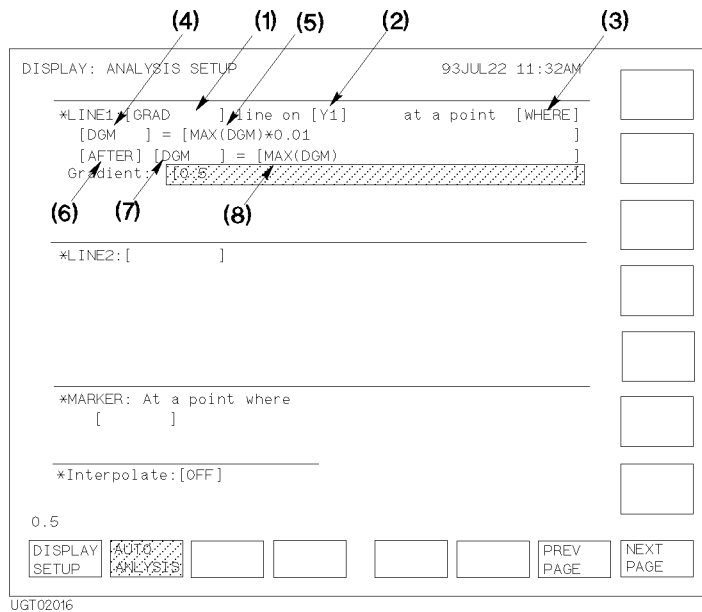

---

## To Draw Tangent to Specified Measurement Point

1. Press **Display** front-panel key.
2. Confirm that **ON** is set on the **LINE** *secondary* softkey on the GRAPH/LIST: GRAPHICS page.
3. Select **ANLYSIS SETUP** primary softkey. The DISPLAY: ANALYSIS SETUP page is displayed.
4. In field (1), select **TANGENT** secondary softkey.
5. In field (2), select secondary softkey to specify desired axis.
6. In field (3), select secondary softkey to select desired data variable name.
7. In field (4), enter desired expression.
8. In field (5), select:
  - **AFTER** secondary softkey if you want to set a search start condition for finding specified point.
  - **DISABLE** secondary softkey to disable (clear) the **AFTER** settings.
9. If you selected **AFTER**, select secondary softkey to enter desired data variable in field (6).
10. If you selected **AFTER**, enter desired expression in field (7).

Data condition mode specifies a point related to the measurement curve. So, if no measurement data satisfy the specified condition, the nearest measurement point is used.

For the meaning of expression that you can enter in step 6 and 9, see “Expression” in “Data Variable and Analysis Function” in *HP 4155A/4156A User’s Dictionary Reference*.

### **To specify a point between two measurement points.**

Set Interpolate field to **ON**.

### **To disable (clear) the settings.**

Move the pointer to field (1), then select **DISABLE** secondary softkey. Setup fields disappear.

Example

The following figure shows an example setup to automatically draw a tangent line to a specified measurement point.

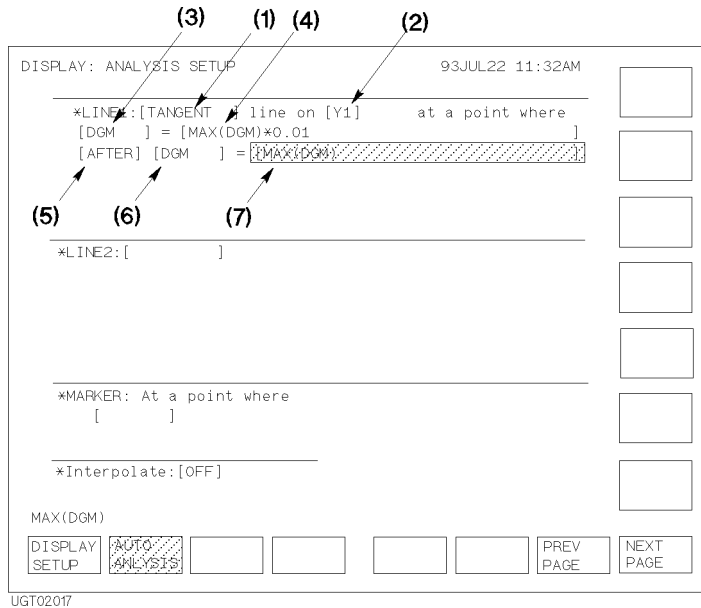



---

## To Draw Regression Line by Specifying Two Points

1. Press **Display** front-panel key.
2. Confirm that **ON** is set on the **LINE** *secondary* softkey on the GRAPH/LIST: GRAPHICS page.
3. Select **ANLYSIS SETUP** primary softkey. The DISPLAY: ANALYSIS SETUP page is displayed.
4. In field (1), select **REGRESSION** secondary softkey.
5. In field (2), select secondary softkey to specify desired axis.
6. In field (3), select:
  - **BY X-Y COORDINATE** secondary softkey to specify a point by X-Y coordinate mode. (Go to step 6.)
  - **BY DATA CONDITION** secondary softkey to specify a point by data condition mode. (Go to step 7.)
7. If you selected **BY X-Y COORDINATE** secondary softkey:
  - a. In the X field, enter desired expression to specify X coordinate.
  - b. In the Y field, enter desired expression to specify Y coordinate.
  - c. Go to step 8.
8. If you selected **BY DATA CONDITION** secondary softkey:
  - a. In field (4), select secondary softkey to set desired data variable name.
  - b. In field (5), enter desired expression.
  - c. In field (6), select:
    - **AFTER** secondary softkey if you want to set a search start condition for finding specified point.
    - **DISABLE** secondary softkey to disable (clear) the **AFTER** settings.
  - d. If you selected **AFTER**, select secondary softkey to enter desired data variable in field (7).
  - e. If you selected **AFTER**, enter desired expression in field (8).
9. Specify the other point by step 5, then step 6 or 7.

Regression calculation is performed in the range defined by the two specified points as shown in the following figure.

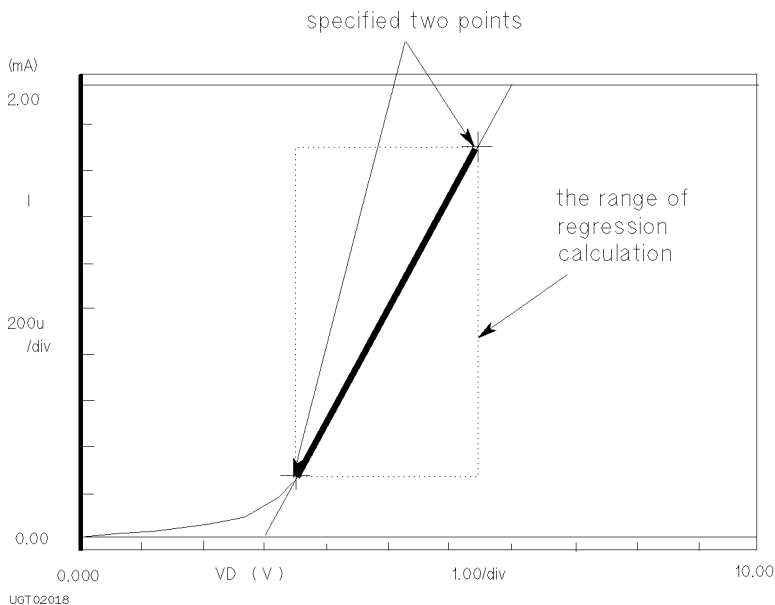

Data condition mode specifies a point related to the measurement curve. So, if no measurement data satisfy the specified condition, the nearest measurement point is used.

For the meaning of expression that you can enter in step 6 and 7, see “Expression” in “Data Variable and Analysis Function” in *HP 4155A/4156A User's Dictionary Reference*.

**To specify a point between two measurement points.**

Set Interpolate field to 0N.

**To disable (clear) the settings.**

Move the pointer to field (1), then select **DISABLE** secondary softkey. Setup fields disappear.

Analyzing Measurement Results

**Automatic Analysis**

Example

The following figure shows an example setup to automatically draw a regression line. The range for the regression calculation is specified by two points. One point is specified by X-Y coordinate mode and other point is specified by data condition mode.

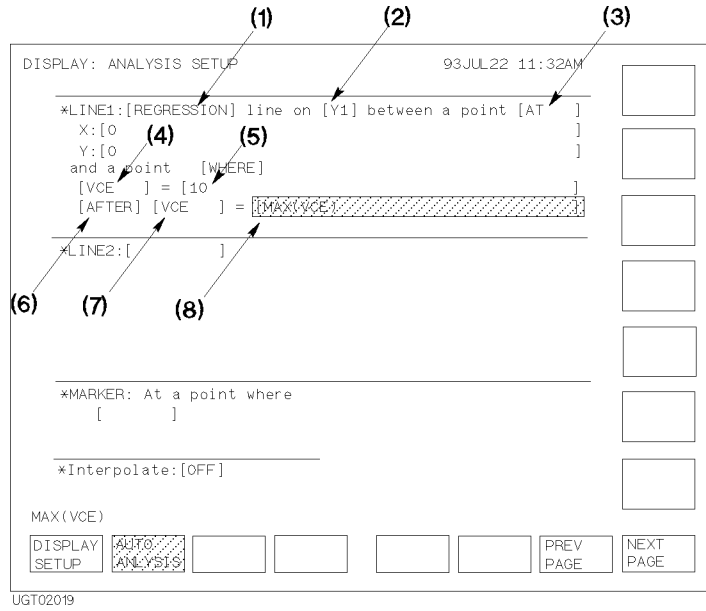

---

## To Display Marker at Specified Point

1. Press **Display** front-panel key.
2. Select **ANLYSIS SETUP** primary softkey. The DISPLAY: ANALYSIS SETUP page is displayed.
3. Move pointer to field (1), then select secondary softkey to set desired data variable name.
4. In field (2), enter desired expression.
5. In field (3), select:
  - **AFTER** secondary softkey if you want to set a search start condition for finding specified point.
  - **DISABLE** secondary softkey to disable (clear) the **AFTER** settings.
6. If you selected **AFTER** in field (4), select secondary softkey to set desired data variable.
7. If you selected **AFTER** in field (5), enter desired expression.

The marker can be displayed on the measurement curve only. So, if no measurement data satisfy the specified condition, the nearest measurement point is used.

For the meaning of expression that you can enter in step 4 and 7, see "Expression" in "Data Variable and Analysis Function" in *HP 4155A/4156A User's Dictionary Reference*.

### **To specify a point between two measurement points.**

Set Interpolate field to **ON**.

Analyzing Measurement Results

**Automatic Analysis**

Example

The following figure shows an example setup to automatically display marker at specified point.

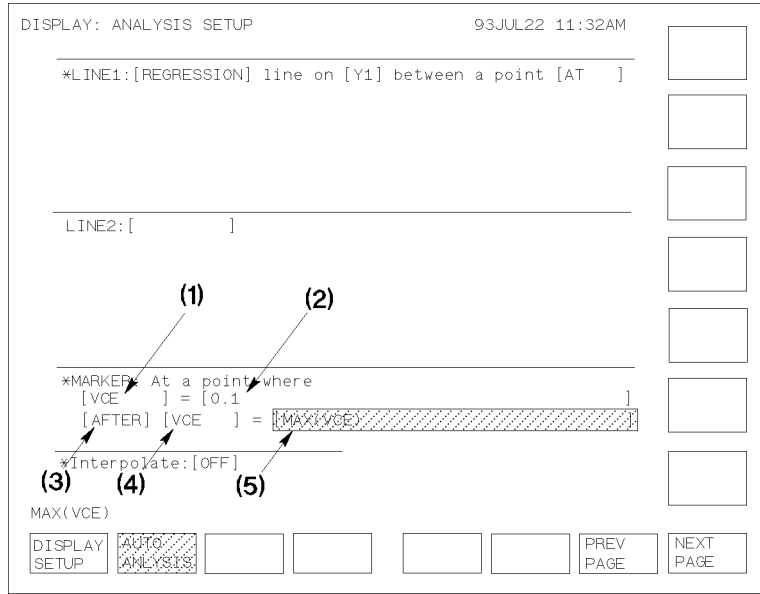

UGT02020



Filer

---

## Filer

HP 4155A/4156A has file, print, and plot functions. The information about these functions is organized into the following two sections:

- File Operation
- Hardcopy

---

## File Operations

This section covers the following file operation tasks:

- To list file names stored on diskette
- To store setup or result data onto diskette
- To store setup or result data into internal memory
- To store result data in spreadsheet format
- To load setup or result data from diskette
- To load setup or result data from internal memory
- To rename a file on diskette
- To remove a file from diskette
- To copy file on diskette to another diskette
- To copy setup or result data from internal memory to diskette
- To initialize a diskette
- To backup a diskette

You can use these file operations on internal memory and disk memory of HP 4155A/4156A.

You can perform file operations as follows:

- Selecting softkeys on the SYSTEM: FILER page. *All* file operations can be performed.
- Selecting the front-panel keys ((Get) and (Save)) of the User File key group. *Only* store and load file operations can be performed.



Filer

## File Operations

### SYSTEM: FILER page.

All file operations can be performed by selecting the secondary softkeys on the SYSTEM: FILER page. The SYSTEM: FILER page is displayed by pressing **(System)** front-panel key, then selecting **FILER** primary softkey.

On SYSTEM: FILER page, you *cannot* enter lowercase characters for file names. If you do, an error occurs. Following figure shows SYSTEM: FILER page.

SYSTEM: FILER 92APRO: 02:30PM

FILE CATALOG

FILE NAME	SIZE[byte]	DATE	TIME	[COMMENT]
SYS1 .CST	234	92-09-21	12:10	1234567890123456
CM0S1234.PRO	1234	92-09-22	14:00	sample 1
CM0S1234.DAT	123456	92-09-22	16:23	channel-length 1
B2345678.PRO	1234	92-09-23	10:33	sample 2
B2345678.DAT	123456	92-09-23	11:10	anneal 1
PROG1	2345	92-09-23	14:52	sample 3

(1)

FUNCTION: (2)

(3)

FILE CATALOG SAVE GET PURGE RENAME COPY DISK OPERATION

FILER MISCEL-LANEOUS CONFIG CALIB/DIAG PRINT SETUP COLOR SETUP

UGT03001

The SYSTEM: FILER page has the following areas:

- (1) FILE CATALOG area  
Lists names of files stored on diskette and other information.
- (2) FUNCTION field  
Displays the file function selected by secondary softkey.
- (3) FUNCTION setup area  
Displays the setup fields for the selected file function.

### Front panel keys of User File key group.

You can also perform the store operation by selecting the **(Save)** key. And can perform the load function by selecting the **(Get)** key.

---

## To List File Names Stored on Diskette

1. Insert a diskette into flexible disk drive.
2. Press **(System)** front-panel key.
3. Select **FILER** primary softkey to display the SYSTEM: FILER page.
4. Select **FILE CATALOG** secondary softkey. File names are listed in the FILE CATALOG area.

For details about information displayed in the FILE CATALOG area, refer to "SYSTEM: FILER page" in "Page Organization" of *HP 4155A/4156A User's Dictionary Reference*.

To move the pointer in the FILE CATALOG area, rotate the rotary knob. If all the file names cannot be displayed in the FILE CATALOG area, you can scroll the file names by rotating the rotary knob.

### To display file comments.

Select one of the following:

- For selected file: select **READ COMMENT** secondary softkey.
- For all files: select **READ COMMENT ALL** secondary softkey.

### To exit file catalog.

Select **EXIT FILE CATALOG** secondary softkey.

### To search for a desired file name.

Enter an alphanumeric character. Field pointer moves to first file name that starts with entered character.

Filer  
**File Operations**

Example

The following figure shows example that displays file catalog.

SYSTEM: FILER 92APRO: 02:30PM

FILE CATALOG

FORMAT:DOS VOLUME: HP4155 USED= 345 AVAIL= 1143

FILE NAME	SIZE[byte]	DATE	TIME	[COMMENT]
SYS1	234	92-09-21	12:10	1234567890123456
CMOS1234.PRO	1234	92-09-22	14:00	sample 1
CMOS1234.DAT	123456	92-09-22	16:23	channel-length 1
B2345678.PRO	1234	92-09-23	10:33	sample 2
B2345678.DAT	123456	92-09-23	11:10	anneal 1
PROG1	2345	92-09-23	14:52	sample 3

FUNCTION: 1/6

FILE CATALOG  
EXIT  
FILE CATALOG  
  
READ COMMENT  
READ COMMENT ALL

FILER MISCEL-LANEOUS CONFIG CALIB/DIAG PRINT SETUP COLOR SETUP

UGT03002

---

## To Store Setup or Result Data onto Diskette

1. Insert a diskette into flexible disk drive.
2. Press **Save** front-panel key to display SAVE setup fields. Or press the **System** front-panel key, select **FILER** primary softkey, then select the **SAVE** secondary softkey.
3. In the NAME field, enter the file name in which you want to store data:
  - maximum characters for HP LIF file: 6 (You cannot set “\_” for the last character.)
  - maximum characters for DOS file: 8
4. In the TYPE field, select:
  - **MES** secondary softkey for measurement setup data.
  - **STR** secondary softkey for stress setup data.
  - **DAT** secondary softkey for measurement setup and result data.
  - **CST** secondary softkey for customized system data.
5. (Optional) In COMMENT field, enter a comment. Maximum characters: 16  
The specified comment will be displayed in the COMMENT field of the FILE CATALOG area.
6. Select **EXECUTE** primary softkey. Specified data is saved to diskette.
7. Select **EXIT** primary softkey to exit SAVE function.

### To list file names on diskette.

Select **FILE CATALOG** secondary softkey. You can fill in the NAME and TYPE fields by rotating the rotary knob to move to the desired file name, then selecting the **SELECT** softkey.

Filer

## File Operations

Example

The following figure shows an example that stores the present measurement setup data onto a diskette.

FUNCTION: SAVE

NAME	<input type="text" value="MOS1"/>	TYPE	<input type="text" value="MES"/>	COMMENT	<input type="text" value="channel len 1"/>
------	-----------------------------------	------	----------------------------------	---------	--

UGT03003

### Situations when you Cannot Store Files

front-panel key is available from any page. However, pressing  is ignored for the following conditions:

- during measurement or forcing stress
- when error message is displayed
- when the PRINT/PLOT setup area is displayed by  front-panel key
- when the HELP page is displayed
- when the KNOB SWEEP page is displayed

---

## To Store Setup or Result Data into Internal Memory

1. Press **Save** front-panel key to display SAVE setup fields. Or press **System** front-panel key, select **FILER** primary softkey, then select **SAVE** secondary softkey.
2. In the NAME field, select secondary softkey for the memory to which you want to store data.
3. In the TYPE field, select:
  - **MES** secondary softkey to store measurement setup data
  - **STR** secondary softkey to store stress setup data
  - **DAT** secondary softkey to store measurement setup and result data
4. (Optional) In COMMENT field, enter a comment. Maximum characters: 16  
The specified comment will be displayed on the label (2nd and 3rd lines) of secondary softkey for internal memory.
5. Select **EXECUTE** primary softkey. The specified data is stored into the internal memory. If any data is presently stored in the internal memory, the data will be lost.
6. Select **EXIT** primary softkey to exit SAVE function.

Filer

## File Operations

Example

The following figure shows an example that stores the present measurement setup and result data into internal memory.

FUNCTION: SAVE

NAME	MEM	<input type="text" value="1"/>	TYPE	<input type="text" value="DAT"/>	COMMENT	<input type="text" value="Anneal 1"/>
------	-----	--------------------------------	------	----------------------------------	---------	---------------------------------------

UGT03004

### Situations when you Cannot Store Files

**Save** front-panel key is available from any page. However, pressing **Save** is ignored for the following conditions:

- during measurement or forcing stress
- when error message is displayed
- when the PRINT/PLOT setup area is displayed by **Plot/Print** front-panel key
- when the HELP page is displayed
- when the KNOB SWEEP page is displayed

---

## To Store Result Data in Spreadsheet Format

1. Insert a diskette into flexible disk drive.
2. Display result data on the GRAPH/LIST: LIST page.

To display GRAPH/LIST: LIST page, press **Graph/List** front-panel key.  
If displayed page is GRAPH/LIST: GRAPHICS page, press **Graph/List** front-panel key again to display GRAPH/LIST: LIST page.
3. Select **SPREAD SHEET** softkey to display ASCII SAVE setup window.
4. In NAME field, enter name of file (without extension) in which you want to save data.
5. In OUTPUT DATA field, enter the range of result data you want to save (corresponds to NO. column of LIST page).
  - left field: upper limit
  - right field: lower limitSelect **ALL** secondary softkey to specify all result data.
6. In UNIT field, select:
  - **ON** secondary softkey to save units (such as V or ms) with result data.
  - **OFF** secondary softkey to not save units.If UNIT is **ON**, result data will be treated as string data, not numeric data. Ineffective value (----) is treated as string, even if you set this field to **OFF**.
7. In the DELIMITER field, select:
  - **SPACE** softkey to specify space to be data delimiter.
  - **TAB** softkey to specify tab to be data delimiter.
  - **COMMA** softkey to specify comma to be data delimiter.



Filer

## File Operations

8. In the STRING MARK field, select:
  - **NONE** softkey to specify no string marker.
  - **" "** softkey to specify " " to be string marker.
  - **' '** softkey to specify ' ' to be string marker.
9. Select **EXECUTE** primary softkey. The result data is saved to specified file, and .TXT extension is automatically added.
10. Select **EXIT** primary softkey to exit ASCII SAVE window.

### To list file names on diskette.

Select **FILE CATALOG** secondary softkey.

For details about output format, see "GRAPH/LIST: LIST page" in *HP 4155A/4156A User's Dictionary Reference*.

Example 1

The following figure shows example setup to save result data in a format that can be used in Lotus 1-2-3®.

FUNCTION : ASCII SAVE

NAME	MOS1	UNIT	OFF
OUTPUT DATA (INDEX NO)	1 <--> MAX	DELIMITER	COMMA
		STRING MARK	" "

UGT03024, 120x40

Example 2

The following figure shows example setup to save result data in a format that can be used in Microsoft® Excel®.

FUNCTION : ASCII SAVE

NAME	MOS1	UNIT	OFF
OUTPUT DATA (INDEX NO)	1 <--> MAX	DELIMITER	TAB
		STRING MARK	NONE

UGT03025, 120x40

---

## To Load Setup or Result Data from Diskette

1. Insert a diskette into flexible disk drive.
2. Press **Get** front-panel key to display GET setup fields. Or press **System** front-panel key, select the **FILER** primary softkey, then select **GET** secondary softkey.
3. Select **FILE CATALOG** secondary softkey.
4. Move the pointer to the desired file name by using rotary knob.
5. Select **SELECT** secondary softkey. This sets the NAME and TYPE entries.
6. Select **EXECUTE** primary softkey. The specified file is loaded.
7. Select **EXIT** primary softkey to exit GET function.

See following page for what occurs if setup file does not match present configuration:

**File Operations****If Setup File does not Match Present Configuration**

If the measurement unit configuration of setup file on diskette differs from configuration of present system, HP 4155A/4156A may change automatically the setup values when loading the setup file. Refer to the following conditions:

- When source file setup has HPSMU, but present system has HRSMU or MPSMU instead:

Measurement Range

Setup file	Changes to
200 V	100 V
1 A	100 mA

- When source file setup has HRSMU, but present system has HPSMU or MPSMU instead:

Measurement Range

Setup file	Changes to
10 pA	1 nA
100 pA	1 nA

Example

The following figure shows an example that loads measurement setup and result data from a diskette.

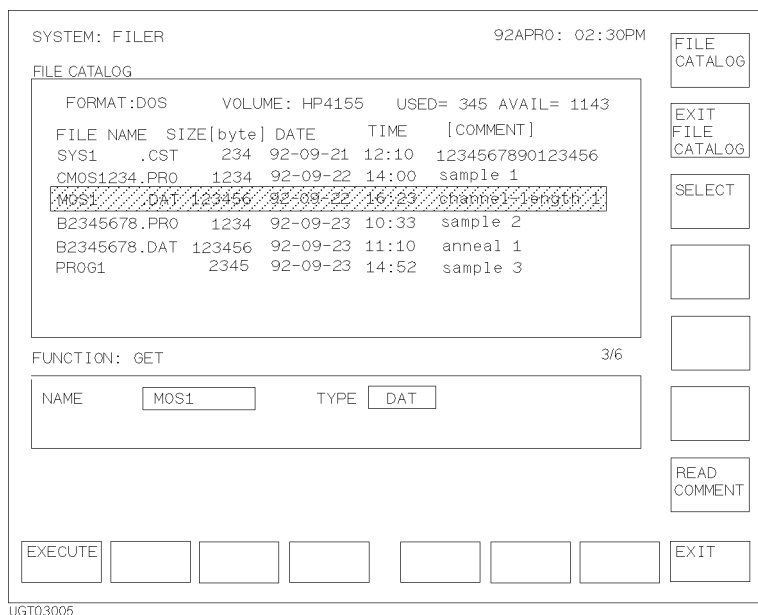

### Situations when you Cannot Get Files

**Get** front-panel key is available from any page. However, pressing **Get** is ignored for the following conditions:

- during measurement or forcing stress
- when error message is displayed
- when the PRINT/PLOT setup area is displayed by **Plot/Print** front-panel key
- when the HELP page is displayed
- when the KNOB SWEEP page is displayed

---

## To Load Setup or Result Data from Internal Memory

1. Press **Get** front-panel key to display GET setup fields. Or press **System** front-panel key, select **FILER** primary softkey, then select **GET** secondary softkey.
2. In the NAME field, select secondary softkey for desired memory. This sets the NAME entry.
3. Select **EXECUTE** primary softkey. Data from the specified memory is loaded.
4. Select **EXIT** primary softkey to exit GET function.

### Example

The following figure shows an example that loads data from an internal memory.

FUNCTION: GET

NAME	MEM	1
------	-----	---

UGT03006

### **Situations when you Cannot Get Files**

**Get** front-panel key is available from any page. However, pressing **Get** is ignored for the following conditions:

- during measurement or forcing stress
- when error message is displayed
- when the PRINT/PLOT setup area is displayed by **Plot/Print** front-panel key
- when the HELP page is displayed
- when the KNOB SWEEP page is displayed

---

## To Rename a File on Diskette

1. Insert a diskette into flexible disk drive.
2. Press **System** front-panel key.
3. Select **FILER** primary softkey to display the SYSTEM: FILER page.
4. Select **RENAME** secondary softkey to display RENAME setup fields.
5. Select **FILE CATALOG** secondary softkey.
6. Move the pointer to the file name to be changed by using rotary knob, then select **SELECT SOURCE** secondary softkey. This sets the NAME and TYPE entries.
7. In the NEW NAME field, enter a new name.
  - maximum characters for HP LIF file: 6
  - maximum characters for DOS file: 8To enter a name from FILE CATALOG area, move to desired name, then select **SELECT TARGET**.
8. Select **EXECUTE** primary softkey. The filename is changed to the specified new name.
9. Select **EXIT** primary softkey to exit RENAME function.

### Example

The following figure shows an example that renames a measurement setup and result file.

FUNCTION: RENAME

NAME	MOS1	TYPE	DAT
NEW NAME	MOS2		

UGT03007

---

## To Remove a File from Diskette

1. Insert a diskette into flexible disk drive.
2. Press **(System)** front-panel key.
3. Select **FILER** primary softkey to display the SYSTEM: FILER page.
4. Select **PURGE** secondary softkey to display PURGE setup fields.
5. Select **FILE CATALOG** secondary softkey.
6. Move the pointer to the file name to be removed by using rotary knob, then select **SELECT** secondary softkey. This sets the NAME and TYPE entries.
7. Select **EXECUTE** primary softkey. A confirmation message is displayed.
8. Select as follows:
  - **YES** primary softkey to remove the file.
  - **NO** primary softkey to cancel removing.
9. Select **EXIT** primary softkey to exit the PURGE function.



Filer

## File Operations

Example

The following figure shows an example that removes a measurement setup and result file from a diskette.

FUNCTION: PURGE

NAME	<input type="text" value="MOS1"/>	TYPE	<input type="text" value="DAT"/>
------	-----------------------------------	------	----------------------------------

UGT03008

### Removing multiple files

After step 6, if you select **\*** secondary softkey in the TYPE field, an asterisk (\*) appears in the TYPE field instead of the extension. When you execute the next steps, all file names with name indicated in the NAME field are deleted.

For example, if NAME field is MOS1 and TYPE field is \*, then the following files are deleted if they exist:

- MOS1.MES
- MOS1.STR
- MOS1.DAT
- MOS1.CST
- MOS1.PRO

---

## To Copy File on Diskette to Another Diskette

1. Insert the diskette that has the source file into flexible disk drive.
2. Press **(System)** front-panel key.
3. Select **FILER** primary softkey to display the SYSTEM: FILER page.
4. Select **COPY** secondary softkey to display COPY setup fields.
5. Select **FILE CATALOG** secondary softkey.
6. Move the pointer to the desired file name by using rotary knob, then select **SELECT SOURCE** secondary softkey. This sets the SOURCE NAME and TYPE entries.
7. In the TARGET NAME field, enter the target file name.
  - maximum characters for HP LIF file: 6
  - maximum characters for DOS file: 8
8. In the TARGET DISK field, select the **OTHER** softkey.
9. Select **EXECUTE** primary softkey.
10. After **Insert Source Diskette** message is displayed, make sure the source diskette is inserted, then select:
  - **YES** primary softkey to copy the file.
  - **NO** primary softkey to cancel copying.
11. After **Insert Target Diskette** message is displayed, insert the target diskette, then select:
  - **YES** primary softkey to copy the file.
  - **NO** primary softkey to cancel copying.
12. Select **EXIT** primary softkey to exit the COPY function.

Filer  
**File Operations**

Example

The following figure shows an example that copies a measurement setup and result file on the diskette to another diskette.

FUNCTION: COPY

SOURCE NAME	MOS1	TYPE	DAT	TARGET DISK	OTHER
TARGET NAME	MOS1				

UGT03009

---

## To Copy Setup or Result Data from Internal Memory to Diskette

1. Press **System** front-panel key.
2. Select **FILER** primary softkey to display the SYSTEM: FILER page.
3. Select **COPY** secondary softkey to display the COPY setup fields.
4. In the SOURCE NAME field, select the secondary softkey of the internal memory that you want to copy.
5. In the TARGET NAME field, enter a target file name.
  - maximum characters for HP LIF file: 6
  - maximum characters for DOS file: 8
6. Make sure target diskette is inserted, then select **EXECUTE** primary softkey.
7. Select **EXIT** primary softkey to exit the COPY function.

### Example

The following figure shows an example that copies data from the desired internal memory to a diskette.

FUNCTION: COPY

SOURCE NAME	MEM	1
TARGET NAME		MOS1

UGT03010

---

## To Initialize a Diskette

1. Press **System** front-panel key.
2. Select **FILER** primary softkey to display the SYSTEM: FILER page.
3. Select **DISK OPERATION** secondary softkey to display setup fields.
4. In the DISK OPERATION field, select **DISK INIT** secondary softkey.
5. In the FORMAT field, select:
  - **DOS** secondary softkey to set DOS format.
  - **HP LIF** secondary softkey to set HP LIF format.
6. (Optional) In the VOLUME NAME field, enter a volume name.
7. Select **EXECUTE** primary softkey.
8. After a confirmation message is displayed, insert the diskette to initialize into the flexible disk drive, then select:
  - **YES** primary softkey to initialize the diskette.
  - **NO** primary softkey to cancel initializing.
9. Select **EXIT** primary softkey to exit the DISK INITIALIZE function.

The PROGRESS STATUS field shows what percent the initialization is completed.

Example

The following figure shows an example that initializes a diskette with DOS format.

SYSTEM: FILER		92APR01 02:30PM		DISK INIT				
DISK OPERATION		DISK INIT		DISK COPY				
FORMAT		DOS						
VOLUME NAME		HP4155						
PROGRESS STATUS								
EXECUTE								EXIT

UGT03011

## To Backup a Diskette

1. Press **System** front-panel key.
  2. Select **FILER** primary softkey to display the SYSTEM: FILER page.
  3. Select **DISK OPERATION** secondary softkey to display setup fields.
  4. In the DISK OPERATION field, select **DISK COPY** secondary softkey.
  5. Insert the source diskette, then select **EXECUTE** primary softkey, then select:
    - **YES** primary softkey to execute disk copy.
    - **NO** primary softkey to cancel disk copy.
  6. After the target diskette message is displayed, remove the source diskette, confirm that target diskette is initialized, insert the target diskette, then select:
    - **YES** primary softkey to execute disk copy.
    - **NO** primary softkey to cancel disk copy.
- Note that source and target diskettes must be same format and size.
7. Select **EXIT** primary softkey to exit the DISK COPY function.

The PROGRESS STATUS field shows what percent the disk copy is completed.

The internal memory capacity may not be sufficient to perform the entire disk copy. If so, swap the source and target disks every time the swap message is displayed.

Example

The following figure shows an example that backs up a diskette.

SYSTEM: FILER 92APR01 02:30PM

DISK OPERATION	DISK COPY
----------------	-----------

PROGRESS STATUS 0%

DISK INIT
DISK COPY

EXECUTE							EXIT
---------	--	--	--	--	--	--	------

UGT03012



Filer

**File Operations**



**————— If You Have A Problem**

---

## If You Have A Problem

This chapter explains how to solve a problem or how to read status and error codes, if you encounter some problem.

This chapter is organized into the following sections:

- When you install the HP 4155A/4156A

This section explains how to solve the problems that may occur when installing the HP 4155A/4156A.

- When you make a measurement

This section explains how to solve the problems that may occur when making a measurement.

- If errors occur

This section lists error codes and messages that may be displayed when operating HP 4155A/4156A. Also, this section describes how to read data status.

### To Get Help Information

To start help function, press the **Help** front-panel key. Then, you can select one of the following primary softkeys.

- **OVERVIEW**

Briefly explains each help softkey.

- **PAGE MAP**

Shows a map of all pages, highlights the present page name, and gives a brief description of the highlighted page name. You can use the arrow keys to highlight another page name, then can display the page by selecting the **SELECT** secondary softkey.

- **FIELD INFO**

Describes field where the pointer is located on the page, how to setup the field, and the setting restrictions. This softkey is not displayed for GRAPHICS, LIST, KNOB SWEEP, or STRESS FORCE page.

- **DATA STAT**

Shows how to read data status, which is displayed at the bottom of GRAPHICS, LIST, KNOB SWEEP, or STRESS FORCE page. This softkey is displayed only for these pages.

- **INPUT AID**

Displays variable names, mathematics functions, and read-out functions, and describes the highlighted name or function. This softkey is not displayed for GRAPHICS, LIST, KNOB SWEEP, or STRESS FORCE page.

You can enter desired variable or function into the selected setup field of a page by selecting **ENTER** secondary softkey, then pressing **Enter** front-panel key.

---

## When You Install the HP 4155A/4156A

This section covers the following basic problems that you may encounter when you install the HP 4155A/4156A, and the solutions.

- If HP 4155A/4156A cannot be powered on
- If measurement units of HP 41501A are not displayed on the CHANNELS: CHANNEL DEFINITION page
- If external keyboard does not work
- If display page does not appear after applying power
- If HP 16442A test fixture is not stable

---

## If HP 4155A/4156A cannot be Powered on

- Check that the power cable is firmly connected to HP 4155A/4156A and to power outlet.
- Check that the front-panel LINE switch is on.
- Check that the voltage selector switch is set properly.

The voltage selector switch is located in the lower-right corner of the rear panel. The following table shows the line voltage selector setting.

<u>Line Voltage</u>	<u>Position</u>
90–132 Vac	left
198–264 Vac	right

- Check that the fuse is good.

The fuse holder is located in the lower-right corner of the rear panel.

1. Turn the HP 4155A/4156A off, then disconnect the power cable from the power outlet.
2. Unscrew the fuse holder on the rear panel.
3. Inspect that the correct fuse is installed, and wire inside the fuse is *not* broken by using a tester.

<u>Line</u>	<u>Fuse type</u>	<u>HP part number</u>
100/120 Vac	UL/CSA T 8A, 250 Vac	2110-0383
220/240 Vac	UL/CSA T 4A, 250 Vac	2110-0014

4. Replace the fuse, if necessary. Then, screw in the fuse holder.
5. Turn the HP 4155A/4156A on.

---

## If Measurement Units of HP 41501A are not Displayed on the CHANNELS: CHANNEL DEFINITION Page

- Check that the power cable is firmly connected to HP 41501A and to power outlet.
- Check that the LINE switch of HP 41501A is on.
- Check that the voltage selector switch is set properly.

The voltage selector switch is located in the lower-right corner of the rear panel. The following table shows the line voltage selector setting.

<b>Line Voltage</b>	<b>Position</b>
90–132 Vac	left
198–264 Vac	right

- Check that the fuse is good.

The fuse holder is located in the lower-right corner of the rear panel.

1. Turn the HP 4155A/4156A and the HP 41501A off.
2. Unscrew the fuse holder on the rear panel.
3. Inspect that the correct fuse is installed, and wire inside the fuse is *not* broken by using a tester.

<b>Line</b>	<b>Fuse type</b>	<b>HP part number</b>
100/120 Vac	UL/CSA T 8A, 250 Vac	2110-0383
220/240 Vac	UL/CSA T 4A, 250 Vac	2110-0014

4. Replace the fuse, if necessary. Then, screw in the fuse holder.
  5. Turn on the HP 41501A first, then turn on the HP 4155A/4156A.
- Check that the interface board of HP 41501A is firmly connected to “To Expander Box Interface” of HP 4155A/4156A rear panel.

---

## If External Keyboard does not Work

- Connect keyboard *first, then* turn on HP 4155A/56A.
- Turn off HP 4155A/4156A, then check that the connector of keyboard is firmly connected into keyboard connector of HP 4155A/4156A front panel.
- Execute the **External Key Controller** diagnostics test on the SYSTEM: SELF-CALIBRATION/DIAGNOSTICS page. If error occurs, write down the displayed error codes and contact the nearest Hewlett-Packard Sales and Service office.

---

## If Display Page does not Appear after Applying Power

- If HP 41501A is installed, *first* turn on the HP 41501A, *then* turn on HP 4155A/4156A.
- If the self-test fails, see “If Errors Occur when You Perform Self-calibration or Diagnostics” in this chapter.

---

## If HP 16442A Test Fixture is not Stable

- Install stabilizers on the HP 16442A. For this procedure, see Chapter 2.
- If you use the HP 16442A test fixture with HP 16440A selector or HP 16441A R-Box, attach HP 16442A to HP 16440A or HP 16441A by using plates and screws. For this procedure, see Chapter 2.



---

## When You Make A Measurement

This section covers the following basic problems that you may encounter when you making a measurement, and the solutions.

- If measured value oscillates when measuring high-frequency devices
- If measured value oscillates when measuring negative resistance
- If noise affects the measured values
- If measured voltage has some error when forcing a large current
- If large current causes high temperature (thermal drift)
- If measurement takes more time than specified
- If measurement damages the device under test
- If you get unexpected data when performing sampling measurement

---

## If Measured Value Oscillates when Measuring High-Frequency Devices

When measuring parameters of high-frequency devices, such as GaAs MESFETs or high-frequency bipolar transistors, oscillation may cause measurement problems. Normal measurement cannot be performed because of oscillation.

To solve this problem:

- For FETs, add resistive ferrite beads as close as possible to the gate.
- For bipolar transistors, add resistive ferrite beads as close as possible to the base or emitter.
- Make connection cables as short as possible. Long wires cause oscillation because of their large inductance.

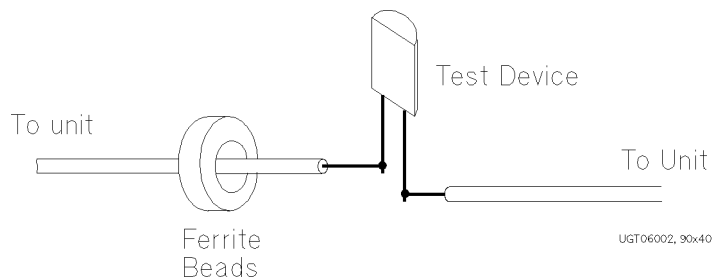

If You Have A Problem  
**When You Make A Measurement**

---

## If Measured Value Oscillates when Measuring Negative Resistance

If the DUT has negative resistance characteristics, SMUs may oscillate. Because SMUs operate as negative feedback amplifier.

To solve this problem:

- For voltage controlled negative resistance device
  - Connect  $G$  in parallel with your DUT to cancel negative resistance. To obtain an output I-V curve, use the following equation.

$$I_Y = I - G * V$$

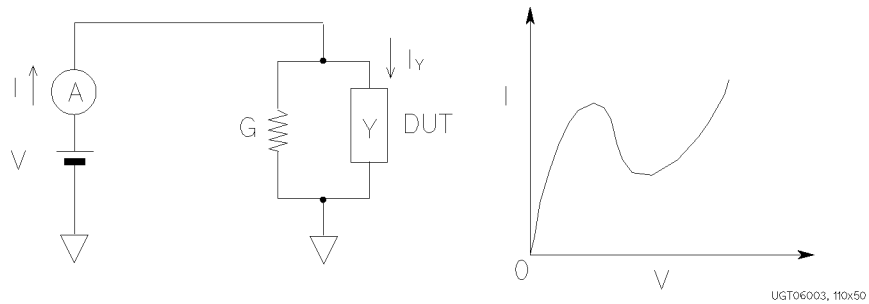

If You Have A Problem  
**When You Make A Measurement**

- For current controlled negative resistance device
  - Connect R in series with your DUT to cancel negative resistance. To obtain an output I-V curve, use the following equation.

$$V_Z = V - R * I$$

- If the resistance of the DUT is less than  $1\text{ M}\Omega$ , you can use R-Box.

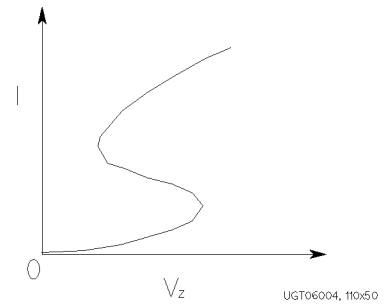
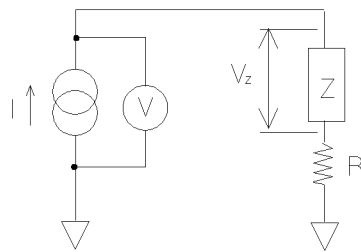

---

## If Noise Affects the Measured Values

When you measure low current of a DUT, the measured values may not be stable.

To solve this problem:

- Use guarding to reduce the leakage current between your prober and HP 4155A/4156A. Note that long wires cause oscillation because of their large inductance. For details about connections, refer to “To Make Connections to Reduce Leakage Current” in Chapter 3.
- If some high-power electric machines are operating around HP 4155A/4156A, turn off the machines, then perform the measurements. The machines affect the power line waveform.
- Shut the lid of test fixture or shield box to prevent effects of light.
- If these are vibrations due to nearby machines or due to air flow, put cushioning material under prober, cable, and HP 4155A/4156A; install stabilizer on the prober; and make the cables stable by taping.
- Wait several minutes after connecting cables or moving probe needles. Because these operations cause electromotive force.
- If you use only Force terminal and triaxial cables for HRSMUs or HPSMU, connect an open cap to sense terminal.
- Keep constant temperature in the room when you use HP 4155A/4156A. Shift of 1 °C may shift the measurement values. Temperature change causes the following.
  - Offset current in HP 4155A/4156A.
  - Thermoelectromotive force in DUT, which causes low current.
  - Expansion and contraction of cables, which causes noise.

---

## If Measured Voltage has some Error when Forcing a Large Current

Voltage measurement may have some error because of the effects of the cable resistance when forcing a large current.

To solve this problem:

- Use Kelvin connections between SMUs and DUT. To cancel the effects of cable resistance, connect the sense line as close as possible to the terminal of the DUT.

For details of Kelvin connections, see “Connection to Device Under Test (DUT)” in Chapter 3.

---

## If Large Current Causes High Temperature (Thermal Drift)

If a large current is forced to a DUT, the temperature of the DUT may increase, which may cause characteristics to drift.

To solve this problem:

- Use the pulse output mode of the SMU.

For large currents, the SMU should be set to pulse output mode. This decreases the average power output to prevent temperature rise of DUT.

## If Measurement Takes More Time than Specified

When measuring current that is 10  $\mu\text{A}$  or less, SMUs may take longer time to measure than the specified integration time. When measuring in a low current range, the SMUs automatically take longer integration time to perform accurate and stable measurements.

To solve this problem:

- Measure current using a fixed range that is more than 10  $\mu\text{A}$ . The measurement will be performed in the specified integration time.

If you set many measurement channels, measurement takes a longer time.

To solve this problem:

- Decrease measurement channels to reduce measurement time.

Note that the number of measurement channels automatically increases if you do *both* the following: force voltage from channels that are connected to R-Box *and* display the voltage values or use voltage values in user functions. The channels automatically measure current, which is used to compensate the voltage values.

---

## If Measurement Damages the Device under Test

When performing breakdown measurements, DUTs may be damaged.

When voltage is forced from an SMU, the current is limited by the compliance setting, which prevents the DUT from being damaged by a large current. But when the current rapidly increases, the current limiter in the SMU cannot follow the rapid current increase, so a large amount of current may flow through the DUT for a moment, which may damage the DUT.

To solve this problem:

- Insert a protecting resistor as close as possible to DUT. You can also use a resistor of the HP 16441A R-Box.

---

## If You Get Unexpected Data when Performing Sampling Measurement

If initial interval is set to a short time and if FILTER ON is set, you may get unwanted data. FILTER ON causes a slower rise time, so short initial interval will sample during this rise time.

To solve this problem:

- Set FILTER field to OFF if you set initial interval to a short time.

Some data may be skipped because measurement takes a long time. Measurement takes a long time if measurement is performed in a low current range, if many measurement channels are set up, or if analysis, such as moving a marker, is performed during measurements.

To solve this problem:

- Measure current using a fixed range that is more than 10  $\mu\text{A}$ . For measurement ranges 10  $\mu\text{A}$  or less, measurement takes longer than the specified integration time.
- Decrease measurement channels to reduce measurement time.

Note that the number of measurement channels automatically increases if you do *both* the following: force voltage from channels that are connected to R-Box *and* display the voltage values or use voltage values in user functions. The channels automatically measure current, which is used to compensate the voltage values.

- Do not perform analysis operation during measurement state



---

## If Errors Occur

If HP 4155A/4156A is not operated correctly, or if diagnostics or calibration fails, error codes and error messages are displayed.

If measurement or forcing stress are not performed correctly, measurement data status is displayed at bottom of GRAPHICS, LIST, KNOB SWEEP, or STRESS FORCE page.

This section describes the following:

- If errors occur when you perform self-calibration or diagnostics
- If error occurs when you operate HP 4155A/4156A
- If measurement data status is displayed.

---

## If Errors Occur when You Perform Self-calibration or Diagnostics

The following are the error codes that are displayed at the bottom of the SYSTEM: SELF-CALIBRATION/DIAGNOSTICS page if errors occur when you perform self-calibration or diagnostics.

If errors occur, write down the displayed error codes and contact the nearest Hewlett-Packard Sales and Service office. Up to seven error codes can be displayed at the bottom of the SYSTEM: SELF-CALIBRATION/DIAGNOSTICS page. To display the error codes, move pointer to a desired test item.

### **Error codes for measurement unit.**

The following are the error codes for measurement units. Error codes are 5-digit numbers.

*1xxyy*

*xx*: measurement unit

00: VSU1,2 and VMU1,2

01 to 06: SMU1 to SMU6

07: PGU1,2

08: GNDU

09: AD converter

*yy*: error number

1x05	AD converter failed ROM or RAM self-test. Measurement unit failed AD converter test as a pretest for calibration or self-test.
1x06	Successive approximation AD converter failed. Measurement unit failed AD converter test as a pretest for calibration or self-test.
1x07	Integrating type AD converter failed. Measurement unit failed AD converter test as a pretest for calibration or self-test.

If You Have A Problem

**If Errors Occur**

1xx08	AD converter test reached timeout. Measurement unit failed AD converter test as a pretest for calibration or self-test.
1xx11	Overvoltage occurred for a measurement unit.
1xx12	Overcurrent occurred for a measurement unit.
1xx15	Measurement units that are not supported are detected.
1xx19	Emergency occurred but the cause is unknown. This is displayed, for example, when unit is known but cause is unknown.
1xx90	AD converter test reached timeout during calibration or self-test for a measurement unit.
1xx91	FIFO (first-in, first-out) for AD converter overflowed because SMU controller takes long time to read measurement data.
1xx92	Calibration or diagnostics was aborted by an emergency or *RST command.
1xx94	HP 4155A/4156A was turned on before HP 41501A.
1xx97	Communication failed between HOST controller and SMU controller. Or calibration/diagnostics was performed, but HOST controller couldn't receive the result from SMU controller.
10030	VSUs and VMUs failed default test of calibration.
10031	VSUs and VMUs failed function check.
10032	VSUs failed gain or offset calibration.
10033	VMUs failed gain or offset calibration.

- 10034 VMUs failed differential mode 2 V range gain or offset calibration.
- 10035 VSUs failed gain and offset calibration, VMUs failed gain and offset calibration, or VMU failed differential mode 2 V range gain and offset calibration.
- 10036 VMUs failed differential mode 0.2 V range gain or offset measurement.
- 10037 VMUs failed differential mode 0.2 V range gain and offset calibration.
- 10038 VMUs and VSUs failed CMR (Common Mode Rejection) amp adjustment.
- 10040 VSU1 and VMU1 failed  $\pm 20$  V measurement self-test in 20 V range.
- 10041 VSU2 and VMU2 failed  $\pm 20$  V measurement self-test in 20 V range.
- 10042 VSU1 and VMU2 failed  $\pm 20$  V measurement self-test in 20 V range.
- 10043 VMU2 and VMU1 failed  $\pm 20$  V measurement self-test in 20 V range.
- 10044 VSU1 and VMU1 failed  $\pm 2$  V measurement self-test in 2 V range.
- 10045 VSU2 and VMU2 failed  $\pm 2$  V measurement self-test in 2 V range.
- 10046 VSU1 and VMU2 failed  $\pm 2$  V measurement self-test in 2 V range.
- 10047 VSU2 and VMU1 failed  $\pm 2$  V measurement self-test in 2 V range.
- 10048 VMUs and VSUs failed differential 2 V range self-test. This test measures  $\pm 2$  V by VMUs in differential mode. (VSU1 is connected to VMU1, and VSU2 is connected to VMU2. VSU1 forces 0 V. VSU2 forces 2 V).
- 10049 VMUs and VSUs failed differential 2 V range self-test. This test measures 0 V by VMUs in differential mode. (VSU1 is connected to VMU1, and VSU2 is connected to VMU2. VSU1 forces 0 V.)

If You Have A Problem

**If Errors Occur**

10050	VMUs and VSUs failed differential 0.2 V range self-test. This test measures 0 V by VMUs in differential mode. (VSU1 is connected to VMU1, and VSU2 is connected to VMU2. VSU1 forces 0 V.)
10051	VMUs and VSUs failed differential 2 V range self-test. This test measures 0 V by VMUs in differential mode. (VSU2 is connected to VMU1 and 2, and forces 0 V.)
10052	VMUs and VSUs failed differential 0.2 V range self-test. This test measures 0 V by VMUs in differential mode. (VSU2 is connected to VMU1 and 2, and forces 0 V.)
10x20	SMU failed function check.
10x21	SMU failed CMR (Common Mode Rejection) amp calibration.
10x22	SMU failed oscillation detector test.
10x23	SMU failed V set and V measure calibration.
10x24	SMU failed I set and I measure calibration.
10x25	SMU failed I bias test.
10x26	SMU failed V switch test.
10760	PGU1 failed pulse gain calibration.
10761	PGU2 failed pulse gain calibration.
10762	PGU1 failed pulse offset calibration.
10763	PGU2 failed pulse offset calibration.

10764	PGU1 failed voltage calibration of base value.
10765	PGU2 failed voltage calibration of base value.
10766	PGU1 failed leading time calibration.
10767	PGU2 failed leading time calibration.
10768	PGU1 failed trailing time calibration.
10769	PGU2 failed trailing time calibration.
10770	PGU1 failed slope offset calibration.
10771	PGU2 failed slope offset calibration.
10772	PGU1 failed slope sampling calibration.
10773	PGU2 failed slope sampling calibration.
10875	GNDU failed offset calibration.
10905	AD converter failed ROM or RAM self-test.
10906	Successive approximation AD converter failed calibration or self-test.
10907	Integrating type AD converter failed calibration or self-test.
10908	AD converter reached timeout. AD converter did not return completion status within certain time after sending calibration or self-test command.

If You Have A Problem

**If Errors Occur**

**Error code for CPU and peripherals.**

The following are the error codes for CPU and peripherals. Error codes are 5-digit numbers.

*2wwwz*

*www*: test item number (on SYSTEM: SELF-CALIBRATION/DIAGNOSTICS page).

*z*: test number

23010	Host DRAM failed self-test.
23021	Host ROM failed checksum test.
23022	Host SRAM failed read and write test.
23023	EEPROM failed read and write test.
23030	Real-time clock failed timer test.
23040	HP-IB controller failed self-test. This test sets some settings, then checks the status.
23050	Serial interface controller failed self-test. This test sets some settings, then checks the status.
23061	Host controller sends a command and does not receive acknowledge from SMU controller.
23062	Host controller failed receiving response from SMU controller by sending a command.
23071	SMU controller ROM failed checksum test.
23072	SMU controller on-board SRAM failed read and write test.

23073	SMU controller internal SRAM failed read and write test.
23074	SMU controller internal timer failed self-test.
23075	SMU controller timer does not operate with correct frequency.
23076	SMU controller failed power on self-test.
23077	SMU controller test gets timeout.
23080	Access to graphics system processor failed read and write test.
23091	Graphic memories (DRAM) failed read and write test.
23092	Graphic memories (VRAM) failed read and write test.
24011	Serial interface failed write test.
24012	Serial interface test gets timeout on write test.
24013	Serial interface controller is not functioning properly for CTS (clear to send).
24014	Serial interface failed read test.
24015	Serial interface test gets timeout on read test.
24016	Serial interface controller is not functioning properly for DCD (data carrier detect).
24021	Trigger output test failed or reached timeout.
24022	Trigger input test failed.



If You Have A Problem

**If Errors Occur**

- 24041 Flexible disk drive controller test failed.
- 24042 Flexible disk drive 5 V power line test failed.
- 24051 Flexible disk drive failed diskette change test.
- 24052 Flexible disk drive failed read and write test.
- 24061 65 V source on post regulator is not output.
- 24062 12 V source on post regulator is not output.
- 24071 A front-panel key is stuck in pressed position.
- 24072 Front key assembly may be disconnected.
- 24073 Front-panel key controller is not functioning properly.
- 24100 External key controller failed self-test.
- 24120 Selector test reached timeout.
- 24130 R-Box test reached timeout.

---

## If an error occurs when you operate HP 4155A/4156A

The following are the error codes and their messages that may occur when you operate HP 4155A/4156A. The error codes and messages are displayed in a message window or in the message display area at the bottom of the page.

- |    |   |
|----|---|
| 1  | Syntax error. Input should be integer number.   |
| 3  | Syntax error. Input should be real number.  |
| 4  | Syntax error. Unrecognized parameter.   |
| 5  | Illegal setup. The parameter is out of range.   |
| 6  | DATA buffer full. Too many APPEND.  |
| 7  | DATA buffer full. Too many points.  |
| 8  | Cannot define more than 6 User Vars.  |
| 9  | Syntax error. First char should be Alphabet.  |
| 10 | Syntax error. Must be alphanumeric.   |
| 12 | Syntax error. Unknown variable name.  |
| 13 | System error. HOSTC received invalid data.<br>HP 4155A/4156A may be broken. Contact the nearest Hewlett-Packard Sales and Service office.     |
| 14 | System error. Unable to communicate with SMUC.<br>HP 4155A/4156A may be broken. Contact the nearest Hewlett-Packard Sales and Service office. |

If You Have A Problem

**If Errors Occur**

- 15           System error. Illegal command to SMUC.  
            HP 4155A/4156A may be broken. Contact the nearest Hewlett-Packard Sales  
            and Service office.
- 16           Illegal operation. Too many LIST data.
- 17           Unable to display data list. Not enough memory.
- 18           Device I/O error. Unable to print out.  
            HP 4155A/4156A, printer, or plotter may be broken. Contact the nearest HP  
            sales and service office.
- 19           Filer error. File name is required.
- 20           Filer error. File Type is required.
- 21           System error. Realtime clock has problem.  
            HP 4155A/4156A may be broken. Contact the nearest Hewlett-Packard Sales  
            and Service office.
- 22           Not 4155A/4156A file.
- 23           File was created by old revision.
- 24           File may be corrupt.
- 25           Zero offset meas failed for <unit name>.  
            Offset value is too large, so Zero offset measurement is aborted.
- 26           Too big offset for 10 pA Range of <unit name>.  
            Offset value is too large, so offset cannot be canceled perfectly.
- 27           System busy. Measuring.

- 28            System busy. Forcing stress.
- 29            System error. EEPROM write error.  
HP 4155A/4156A may be broken. Contact the nearest Hewlett-Packard Sales  
and Service office.
- 30            Fixture open. Measurement aborted.
- 31            Auto calibration was aborted.
- 32            Auto calibration failed.
- 33            No data in internal memory.
- 34            Illegal data. File may be corrupt.
- 35            System busy. Unable to save/get when MEAS/STR.
- 36            System busy. Unable to change Y-axis.
- 37            System error. SMUC lost data.  
HP 4155A/4156A may be broken. Contact the nearest Hewlett-Packard Sales  
and Service office.
- 38            Buffer overflowed. Aborted.
- 39            Syntax error. Undisplayable character.
- 40            Illegal setup. One unit assigned several CH.
- 41            Illegal disk. Revision mismatch.
- 42            Read error occurred.

If You Have A Problem

**If Errors Occur**

- 43 File name is not LIF type.
- 44 File name is not DOS type.
- 45 File name is not LIF/DOS type.
- 46 Volume label is not LIF type.
- 47 Volume label is not DOS type.
- 48 Incorrect memory number.
- 49 Source and Target are same.
- 50 Unable to copy. Memory full.
- 51 Unable to copy. SRC and TGT mem num is same.  
You cannot specify same memory number in both SOURCE and TARGET  
name fields.
- 52 Illegal suffix.
- 53 System busy. Emergency handling.
- 54 System busy. Measuring.
- 55 System busy. Executing cal/diag.
- 56 System busy. Executing auto calibration.
- 57 System busy. Printing out hard copy.

58                   Unable to copy HP4145 data file to memory.

100                   VAR1 is not assigned.

101                   VAR1 assigned to multiple Channels.

102                   VAR2 assigned to multiple Channels

103                   VAR1' assigned to multiple Channels.

104                   VAR1 and VAR1' must be same MODE.

105                   Cannot set multiple SMUs to pulse mode

106                   Cannot use VAR when SAMPLING.

107                   Cannot use SMU pulse when SAMPLING.

108                   Duplicate variable names exist.

109                   The setup is not finished.

110                   Standby chan cannot use R-BOX resistor  
For standby channel, you cannot use R-Box resistor.

111                   Common chan cannot use R-BOX resistor.  
For common mode channel, you cannot use R-Box resistor.

112                   VAR1 step number is out of range.

113                   START and STOP have different sign.

If You Have A Problem

**If Errors Occur**

- 115 SMU pulse Period must be  $\geq$  Width+4ms.
- 116 VAR1 output power too large for unit.
- 117 VAR1' output power too large for unit.
- 118 VAR2 output power too large for unit.
- 119 TOT SMP TM=AUTO is for LINEAR only.  
AUTO can be specified for total sampling time *only when* LINEAR sampling mode is selected.
- 120 Only LINEAR when init int  $\leq$  480  $\mu$ s.  
When initial interval is set to 480  $\mu$ s or less, you *cannot* specify LOG or THINNED-OUT sampling mode.
- 121 For LINEAR set AUTO if init int  $\leq$  480  $\mu$ s  
When initial interval is set to 480  $\mu$ s or less *and* when LINEAR sampling mode is set, AUTO must be set in TOTAL SAMP. TIME field.
- 122 TOT SP TM must be  $\geq$  INIT INT  $\times$  (NOofSMP-1)  
Total sampling time must be set in the following range:  
*total sampling time  $\geq$  initial interval  $\times$  (number of samples - 1)*
- 123 STOP CONDITION NAME is not set.
- 124 PGU pulse Period must be  $>$  Width.
- 125 PGU pulse Period must be  $\geq$  Delay.
- 126 PG leading/trailing must be same range  
PGU leading and trailing time must be set in the same range. For details about the ranges, see "Measurement Units" in *HP 4155A/4156A User's Dictionary Reference*.

- 127            **PGU Leading must be  $\leq 0.8 \times \text{WIDTH}$ .**  
Leading time must satisfy the following equation.  
*leading time  $\leq$  pulse width  $\times$  0.8*
- 128            **PGU Trailing must be  $\leq 0.8 \times (\text{Peri-Wid})$ .**  
Trailing time must satisfy the following equation.  
*trailing time  $\leq$  (pulse period - pulse width)  $\times$  0.8*
- 129            **SMU I range must be  $\leq$  Compliance range.**
- 130            **SYNC channel is not assigned.**  
At least one SYNC channel must be specified.
- 131            **Assigned more than 4 SYNC channels.**
- 132            **Set INIT INT  $\geq 2$ ms for multi-CH MEAS.**  
When you perform multi-channel measurements, initial interval must be 2 ms or more.
- 133            **Use FIXED range when INIT INT  $< 2$ ms.**  
When you use auto ranging or limited auto ranging measurement, you must set initial interval to 2 ms or more.
- 134            **Cannot disable STBY-ON ch in Stress.**  
On STRESS: CHANNEL DEFINITION page, you cannot disable (delete entries in row) channels that are set to STBY ON on the CHANNELS: CHANNEL DEFINITION page.
- 135            **Undefined symbol in user function.**
- 136            **Syntax error in user function.**
- 137            **Too few arguments in user function.**



If You Have A Problem

**If Errors Occur**

- 138 Too many arguments in user function.
- 139 User function area is full.
- 140 Recursive call in user function.
- 141 User function is undefined.
- 142 Stack overflow in user function.
- 143 COMMON channel FCTN must be CONST.
- 144 COMMON channel FCTN must be NSYNC.
- 145 System busy. Unable to change page when MEAS.
- 146 System busy. Unable to change page when STRS.
- 147 Ineffective page in this setup.
- 148 X axis is not assigned.
- 149 Y1 axis is not assigned.
- 150 ENABLE DELAY must be  $\leq 32767 \times \text{INIT INT}$   
For sampling measurements, when stop condition is set to ENABLE, *enable delay* must be *initial interval*  $\times 32767$  or less.
- 151 No unit is set to STANDBY ON.
- 152 System busy. MEASURING (or 4145 USER MODE).
- 153 MIN, MAX have different sign in LOG.

- 154 Can do such operation only for USER VAR.
- 155 Illegal setup. The name was already used.
- 156 User variable is used in user function.  
If a user variable is used in user functions, the user variable cannot be deleted.
- 157 AUTO Analysis is undefined.
- 158 TOT SAMP TIME must be  $\leq \text{INIT INT} \times 32767$ .  
*Total sampling time must be initial interval  $\times$  32767 or less and  $1 \times 10^{11}$  or less.*
- 159 Measure channel is not assigned.
- 160 Unable to find approximate data.
- 161 Illegal graph scale setup.
- 163 The Sweep/Pulse Polarity is not same.
- 164 SYNC can not be set for standby CH.
- 165 Set value is too small for range.  
For LOG sweep measurement, start and stop value must be equal or more than setup resolution. For sweep measurement, step value of VAR1 and VAR2 must be equal or more than setup resolution.
- 166 PGU Peak/Base difference must be  $\leq 40V$
- 170 Use Sweep/Bias instead of SMU Pulse.

If You Have A Problem

**If Errors Occur**

- 171 Knob Sweep sets VAR1' to CONST.  
If you set VAR1' for knob sweep measurement, the VAR1' channel forces a constant value equal to START value. VAR1' cannot be a sweep source for Knob Sweep measurement.
- 172 Cannot do SAMPLING when Knob Sweep.
- 173 |STEP| must be  $\leq$  |STOP-START| .
- 174 Cannot set CONT AT ANY if PCOMP is ON.  
When you set power compliance, you cannot select **CONT AT ANY** secondary softkey.
- 175 CONST setup must be  $\leq$  unit output range .
- 176 Pulse BASE must be  $\leq$  unit output range .
- 177 PGU pulse WIDTH must be  $\geq$  setup res .  
Pulse width of PGUs must be greater than or equal to unit setup resolution.
- 178 TRIG OUT DELAY is too long.  
Trigger out delay must be 32.7 ms or pulse width you specified, whichever is shorter.
- 179 Cannot ENABLE stop if INIT INT  $<$  2 ms .  
When initial interval is set to less than 2 ms, you cannot set stop condition.
- 180 Illegal setup. Target module is not installed .
- 181 Illegal setup. Invalid command .
- 182 Cannot define more than 6 User functions .
- 183 Cannot define more than 8 data vars in lists .

184           Cannot define more than 2 display data vars.  
185           Ascii format does not allow block transfer.  
186           Block size mismatched with data format.  
187           Y2 axis is not assigned.  
188           List name is not assigned.  
189           The specified name is not list name.  
190           Illegal file type is requested.  
191           System busy. Printing out hard copy.  
192           Unable to set. Another controller is on bus.  
193           Unable to specify this name here.  
194           PGU Pulse DELAY must be  $\geq$  setup res.  
              PGU pulse delay time must be  $\geq$  setup resolution.  
195           Cal/Diag failed. Cannot use unit.  
196           Compliance too low to force pulse.  
197           Compliance too high to force pulse.  
198           Two VPULSE PGUs must be same STBY.  
199           Two VPULSE PGUs must be same FCTN.

If You Have A Problem

**If Errors Occur**

201 System error. Filer memory overflow.

202 Filer error. Integer overflow.

204 Filer error. File type is wrong.

205 Filer error. EOF found.

206 Filer error. EOR found.

211 Trigger ignored.

213 Filer error. DISK record is not found.

215 Filer error. DISK record data error.

220 Filer error. Undefined I/O path.

221 Filer error. Permission denied.

224 Filer error. The directory is not empty.

225 Filer error. No DISK in the drive.

226 Filer error. Initialization failed.

227 Filer error. Invalid DISK volume label.

229 Filer error. DISK is not initialized.

230 Filer error. Checkread error.

231 Filer error. Bad HFS DISK.

232 Filer error. DISK is full.

233 Filer error. Directory is full.

234 Filer error. File name is undefined.

235 Filer error. File name is wrong.

236 Filer error. The file name is already used.

237 Filer error. Bad device type.

238 Filer error. Unable to use wildcard.

239 Filer error. Operations failed.

241 Filer error. The target type is wrong.

242 Filer error. The file is protected.

243 Filer error. DISK is protected.

244 System error. Unable to verify.

245 Filer error. Unable to copy between LIF/DOS.

246 Filer error. Reason Unknown.

265 HOLD TM must be  $\geq 0$  when INIT INT  $\geq 2$ ms.

280 VAR1' output value is out of range.

If You Have A Problem

**If Errors Occur**

- 284            Sampling range must be  $\leq$  11decades .
- 286            Cannot execute cal/diag after power fail .  
Turn on HP 4155A/4156A again to perform calibration or diagnostics.
- 288            MEAS not finished . Incomplete data deleted .  
If you press **Stop** front-panel key before the specified measurement finishes,  
incomplete measurement data is deleted.
- 289            STBY ON ch MODE(MEAS/STR) must be same
- 290            Cannot use unit after power fail .
- 292            VAR1' parameters must be  $\geq$  output res  
Start, stop, and step value of VAR1' channel must be unit output resolution or  
more.
- 293            Cal/Diag aborted (failed on some units) .  
Calibration or diagnostics was aborted by receiving \*RST command. So, some  
units maybe failed.
- 300            Over voltage is detected .
- 301            Over Current is detected .
- 302            Power failure at Main Frame .  
Turn on HP 4155A/4156A again. You can use filer functions after selecting OK  
secondary softkey (except when this error occurs during power-on test).
- 303            Power failure at Expander Box .  
Turn on HP 4155A/4156A again. You can use filer functions after selecting OK  
secondary softkey (except when this error occurs during power-on test).
- 305            Cannot shutdown Main Frame .

- 306           **Emergency. Reason unknown.**  
An emergency occurred on an empty slot. Or an emergency occurred on an existing slot, but the reason is unspecified.
- 307           **Cannot shutdown Power Supply.**  
Turn on HP 4155A/4156A again. You can use filer functions after selecting OK secondary softkey (except when this error occurs during power-on test).
- 308           **Unknown emergency (SMUC time out).**  
Perform 305: HOSTC <--> SMUC I/F test on the SYSTEM: SELF-CALIBRATION/DIAGNOSTICS page. If this test fails, HP 4155A/4156A may be broken. Contact the nearest Hewlett-Packard Sales and Service office.
- 309           **The SMU AND PULSE GENERATOR EXPANDER is not turned on.**  
Turn on the expander, then cycle mainframe power."
- 310           **Unsupported unit detected in Slot ##. Turn off the power and remove the unit.**  
The displayed unit must be changed. Contact the nearest Hewlett-Packard Sales and Service office.
- 400           **System error. Undefined method. System bug.**
- 401           **System bug. Invalid parameter.**
- 402           **System bug. Inconsistency.**



---

## If a Measurement Data Status is Displayed.

If measurement or stress force cannot be performed correctly, the measurement data status is displayed at the bottom of the GRAPHICS, LIST, KNOB SWEEP, or STRESS FORCE page. The status indicates hardware and calculation errors.

The status format depends on the displayed page as follows:

### **GRAPH/LIST: GRAPHICS and KNOB SWEEP page.**

Status is displayed in following format:

**STATUS:** *AB AB AB ( A A A A A A A C )*

- *AB AB AB* is for X, Y1, and Y2 axis respectively. No Y2 for KNOB SWEEP.
- *A A A A A A A C* is for SMU1 to SMU6, VMU1, VMU2, and PGU1/2 respectively.

Where, *A*, *B*, and *C* mean as follows:

*A* hardware status error. If multiple errors occur, numbers are added and displayed as a hexadecimal number.

- 1 : AD converter overflow.
- 2 : Oscillation
- 4 : Other channel reached compliance limit.
- 8 : This channel reached compliance limit.

*B* data error. If multiple errors occur, numbers are added and displayed as a hexadecimal number.

- 1 : stack register overflow
- 2 : calculation error
- 4 : only one data for delta measurement. At least 2 data needed.

*C* PGU status

- 1 : PGU average output current exceeds 100 mA.

For non-measurement channels, “\_” is displayed.

**GRAPH/LIST: LIST page.**

Status on GRAPH/LIST: LIST page is displayed in following format:

**STATUS:** *AB AB AB AB AB AB AB AB ( A A A A A A A C )*

- *AB AB AB AB AB AB AB AB* is for the up to 8 LIST variables that can be set up.
- *A A A A A A A C* is for SMU1 to SMU6, VMU1, VMU2, and PGU1/2 respectively.

Where, *A*, *B*, and *C* mean as follows:

*A* hardware status error. If multiple errors occur, numbers are added and displayed as a hexadecimal number.

1 : AD converter overflow.

2 : Oscillation

4 : Other channel reached compliance limit.

8 : This channel reached compliance limit.

*B* data error. If multiple errors occur, numbers are added and displayed as a hexadecimal number.

1 : stack register overflow

2 : calculation error

4 : only one data for delta measurement. At least 2 data needed.

*C* PGU status

1 : PGU average output current exceeds 100 mA.

For non-measurement channels, “\_” is displayed.

If You Have A Problem

**If Errors Occur**

**STRESS: STRESS FORCE page.**

Status on STRESS: STRESS FORCE page is displayed in following format:

STATUS: *A C*

Where, *A* and *C* mean as follows:

*A* hardware status error. If multiple errors occur, numbers are added and displayed as a hexadecimal number.

2 : Oscillation.

4 : Some channel has reached compliance limit.

*C* PGU status

1 : PGU average current exceeds 100 mA.

**Manual Changes  
Depending on ROM Version**

---

## Manual Changes Depending on ROM Version

HP 4155A/4156A may vary slightly, depending on the version of the ROM based firmware. The information in this manual applies to an HP 4155A/4156A with the following ROM version.

### Manual Applies to this ROM Version

ROM	ROM Version
HOSTC	01.02

#### ROM version

To confirm your ROM version, check the **SOFTWARE REVISION** field on the **SYSTEM: CONFIGURATION** page.

This chapter contains information for customizing this manual so that it is correct for the HP 4155A/4156A that you are using.

To customize this manual for your HP 4155A/4156A, refer to the following table, and make the manual changes depending on the ROM version of your HP 4155A/56A.

### Manual Changes by ROM version

ROM version (HOSTC)	Make Manual Changes
01.00	1
01.01	1

---

## Change 1

- Hardcopy
  - COLOR / B/W field (Page 5-29)

**FIX CLR** secondary softkey and fixed color mode are not available.
  - RESOLUTION field (Page 5-30)

HP 4155A/4156A does not set the resolution of your PCL printer to the value specified in the RESOLUTION field. You need to set the RESOLUTION field to the same value as actual printer resolution setting.
  - OUTPUT REGION table (Page 5-45)

**STORE REGION** secondary softkey and **RECALL REGION** secondary softkey to store and recall the output region settings into internal memory are not available.

Manual Changes Depending on ROM Version

**Change 1**

