

461/462 Series

ULTRAlign™ Precision, Integrated, Crossed-Roller Bearing Linear Stages

Key Features

- 1 in. (25.4 mm) and compact 0.5 in. (12.7 mm) travel versions
- Stainless steel construction with crossed roller bearings for high stability and rigidity
- Angular deviation better than 100 μ rad about any axis—guaranteed
- Left- and right-hand configurations

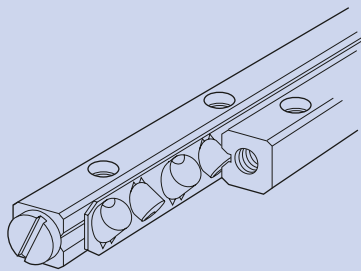

Preloaded crossed-roller bearings provide repeatable, zero stick-slip linear motion with negligible side-play. The roller strips hold cylindrical rollers alternately inclined 90° to assure constant linear contact with the hardened and ground ways.

See our website for CAD files.

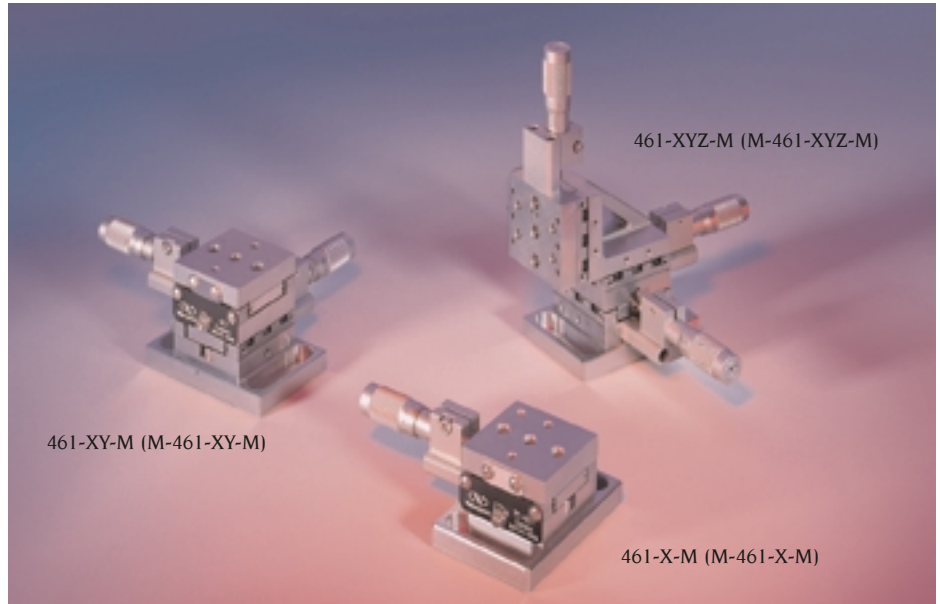

Order actuators separately

461 and 462 Series ULTRAlign™ Integrated Linear Stages feature stainless steel construction for high stability, with thermally matched, hardened steel crossed-roller bearings for unsurpassed performance. The crossed-roller bearings and precision-manufactured bearing reference surfaces provide exceptionally linear travel, with angular deviation better than 100 μ rad about any axis.

Our analysis has shown that optimum stability demands that not only the stage be built of stainless steel, but also the angle brackets, actuator mounts, and even the assembly hardware. Holographic testing has demonstrated sub-micron stability of these stages over a temperature change of 10°C.

ULTRAlign stages overcome the limitations of multi-axis stages

derived from traditional tooling industry designs. The actuators are located out-of-the-way of oversized loads. Z-axis stages do not depend on springs for support, ensuring maximum vertical load capacity.

Generous hole patterns provide easy mounting, with your choice of English (1/4-20) or metric (M6) threaded holes and spacing. The mounting base can be removed for a lower profile. Each axis features a non-influencing locking mechanism for negligible motion of the stage when locking or unlocking. Specially designed actuator mounting blocks allow quick and easy actuator changes, on any axis, at any time.

Both right and left-handed stages are available for convenient actuator adjustment. When a smaller footprint is necessary, side-drive versions are available as an option.

Specifications

	461 Series	462 Series
Maximum Stage Travel [in. (mm)]	0.5 (13)	1.0 (25)
Angular Deviation (μrad)	<100	<100
Load Capacity, Centered [lb (N)]	20 (89)	43 (191)
Load Capacity, Vertical [lb (N)]	8 (36)	15 (67)

Ordering Information

Stages

Model (Metric)	Actuators Required*	Price
461 Series [0.5 in. (13 mm) travel versions]		
461-X-M (M-461-X-M)	1	\$371
461-XY-M (M-461-XY-M)	2	\$661
461-XY-LH-M (M-461-XY-LH-M)	2	\$661
461-XYZ-M (M-461-XYZ-M)	3	\$890
461-XYZ-LH-M (M-461-XYZ-LH-M)	3	\$890
461-XZ-M (M-461-XZ-M)	2	\$679
461-Z-M (M-461-Z-M)	1	\$399
462 Series [1 in. (25 mm) travel versions]		
462-X-M (M-462-X-M)	1	\$474
462-XY-M (M-462-XY-M)	2	\$812
462-XY-LH-M (M-462-XY-LH-M)	2	\$812
462-XYZ-M (M-462-XYZ-M)	3	\$1,225
462-XYZ-LH-M (M-462-XYZ-LH-M)	3	\$1,225
462-XZ-M (M-462-XZ-M)	2	\$893
462-Z-M (M-462-Z-M)	1	\$568
Side-Drive Mounting Kits for 462 Series		
SDK-1	Side-Drive Kit, X or Y Axis	\$50
SDK-2	Side-Drive Kit, Z Axis	\$50

* Actuators must be ordered separately

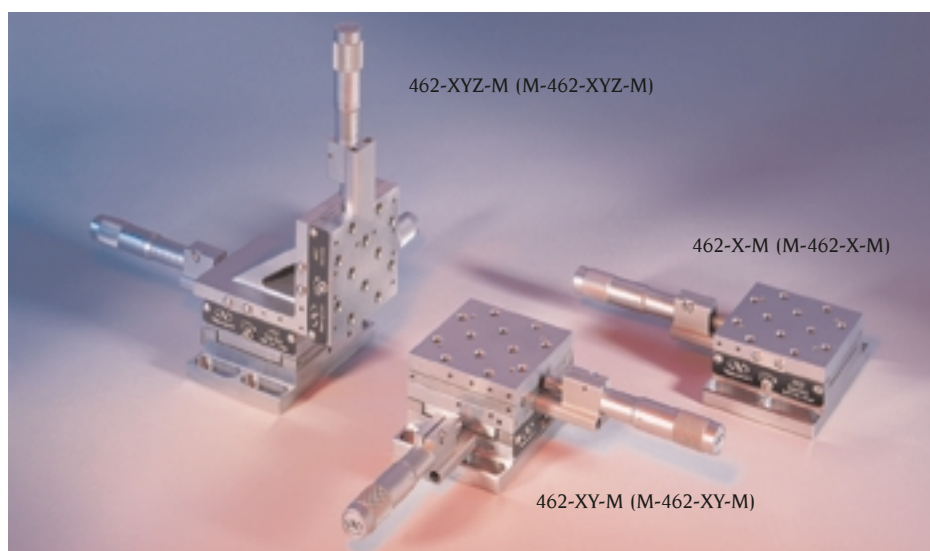

Order actuators separately

Email: sales@newport.com • Web: www.newport.com

Side-Drive Mounting Kits

Configuration	Kit(s) Required	No. Required
X-Axis	SDK-1	1
XY-Axis	SDK-1	2
XYZ-Axis	SDK-1 and SDK-2	2 and 1

Left-handed versions of the XY and XYZ configurations contain “-LH” in the Model number.

For **Vacuum Compatible** versions (50% price premium at time of order), append “V” to the part number, eg., 462-X-MV. Please see page 837 for specifics.

For **space saving side-drive mounting configurations** (no additional cost at time of order), substitute “SD” for “M”, i.e. 462-X-SD. **Field upgrades** to side-mounted actuator configurations are available via the appropriate kit below. 461 Series not available in side drive version.

Recommended Actuators

Manual Drives	Description	461 Series (M-461 Series)	462 Series (M-462 Series)	Travel (mm)	Sensitivity (µm)
AJS Series	Fine Adjustment Screw	•	•	13–25	0.6–0.9
HPS Series	Fine Adjustment Screw	•		13	0.75–0.9
SM-13	Micrometer	•		13	1
SM-25	Micrometer		•	25	1
HR-13	High-Resolution Micrometer	•		13	0.5
HR-1	Long Travel, High-Resolution Micrometer		•	25	0.25
DM-13	Differential Micrometer	•		13	0.1
DM-13L	Differential Micrometer	•		13	0.1
DM-25L	Differential Micrometer		•	25	0.1
Motorized Drives					
850G Series	Motorized Actuator	•	•	50	1
CMA Series	Motorized Actuator	•	•	12.5–25	0.2–0.5
PM500-1A Series	Motorized Actuator	•	•	25	0.05–0.1
AD Series	Electrostrictive Actuator	•	•	13	0.04–0.06

Model 461-Z-M

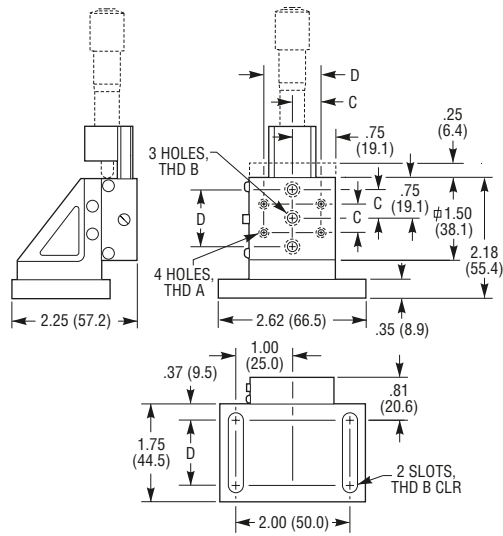

Model 461-X-M

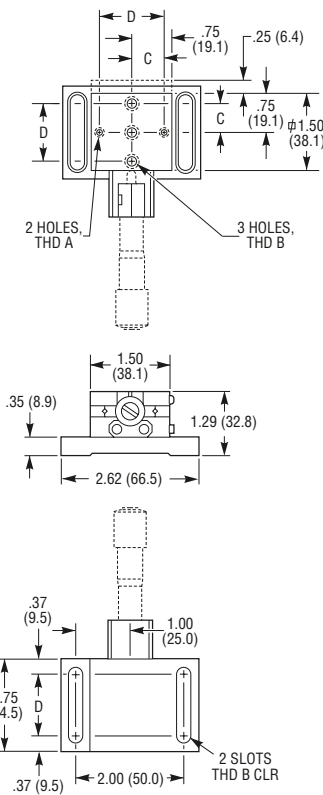

Model 461-XY-M (RH shown, LH opposite)

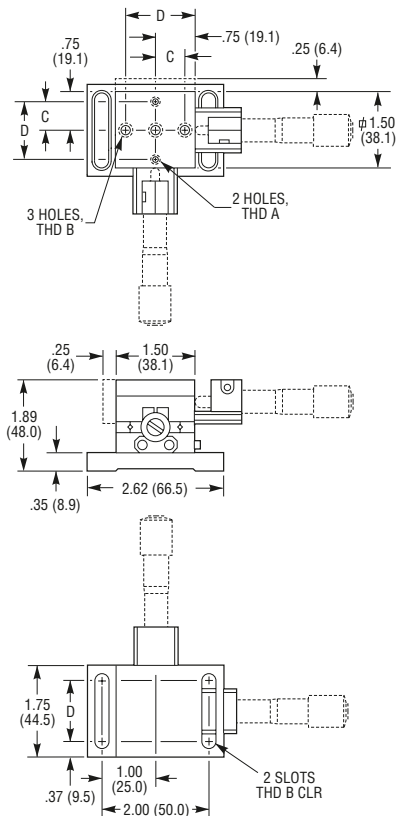

Model (Metric)	Thread		Dimension [in. (mm)]	
	A	B	C	D
461-X-M (M-461-X-M)	8-32 (M4)	1/4-20 (M6)	0.500 (12.5)	1.000 (25.0)
461-XY-M (M-461-XY-M)	8-32 (M4)	1/4-20 (M6)	0.500 (12.5)	1.000 (25.0)
461-XYZ-M (M-461-XYZ-M)	8-32 (M4)	1/4-20 (M6)	0.500 (12.5)	1.000 (25.0)
461-XZ-M (M-461-XZ-M)	8-32 (M4)	1/4-20 (M6)	0.500 (12.5)	1.000 (25.0)
461-Z-M (M-461-Z-M)	8-32 (M4)	1/4-20 (M6)	0.500 (12.5)	1.000 (25.0)

Model 461-XZ-M

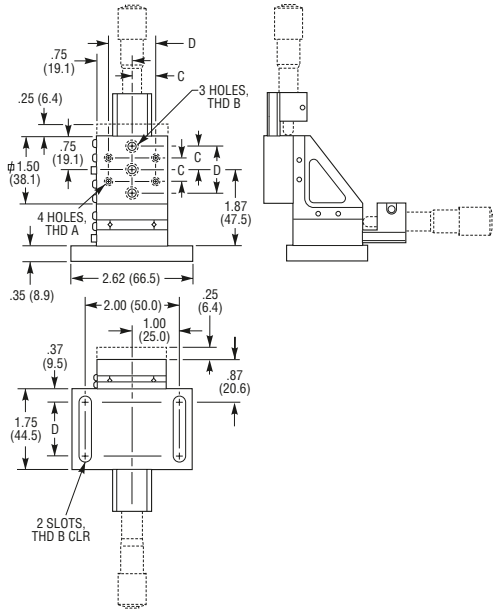

Model 461-XYZ-M (RH shown, LH opposite)

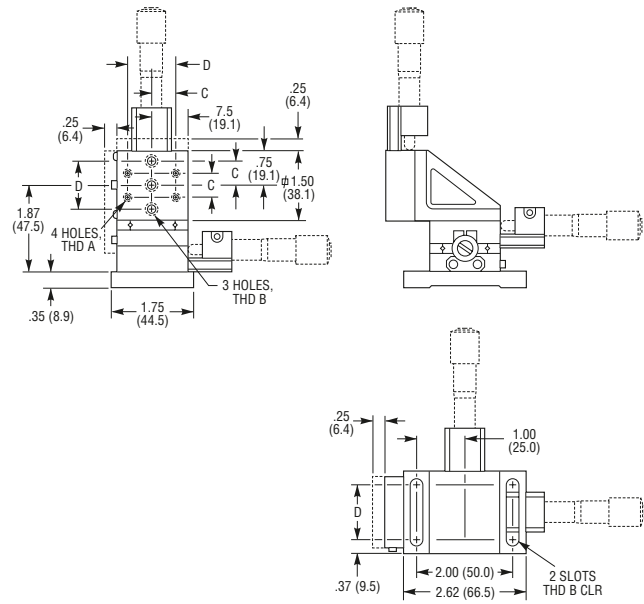

Model 462-X-M

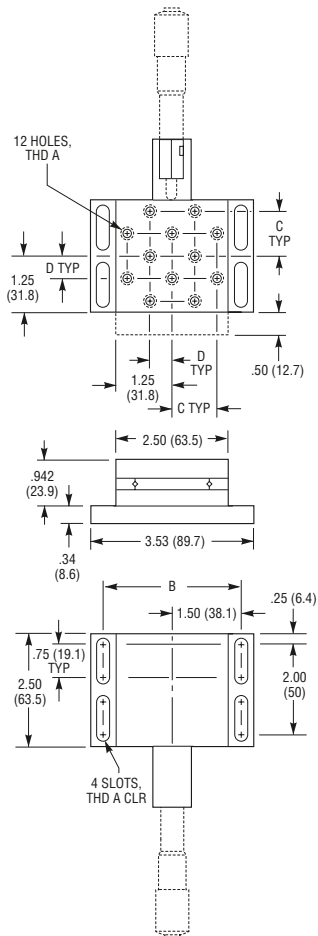

Model 462-XYZ-M (RH shown, LH opposite)

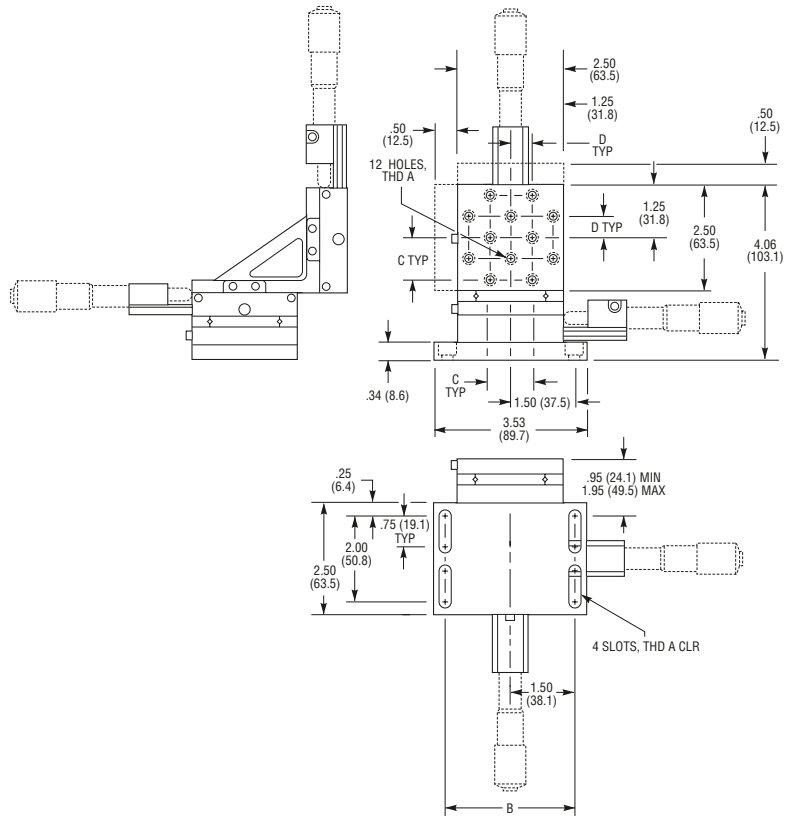

MANUAL LINEAR TRANSLATION STAGES
 MOTORIZED LINEAR TRANSLATION STAGES
 MANUAL ROTATION STAGES
 MOTORIZED ROTATION STAGES
 FIBER POSITIONERS
 ACTUATORS
 CONTROLLERS & AMPLIFIERS
 TECHNICAL REFERENCE

Model 462-XY-M (RH shown, LH opposite)

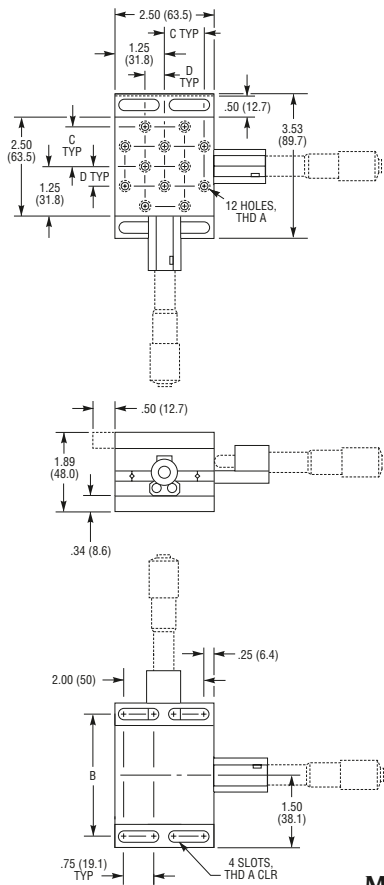

Model 462-XZ-M

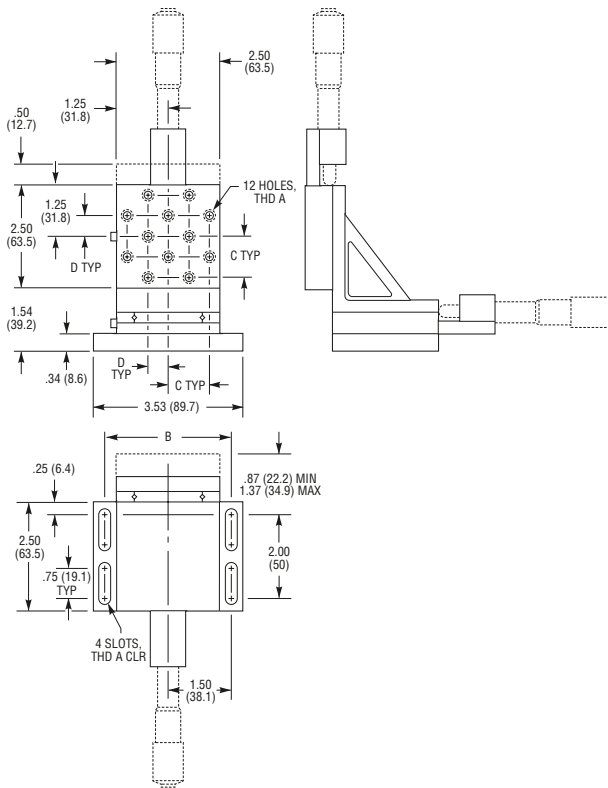

Model 462-Z-M

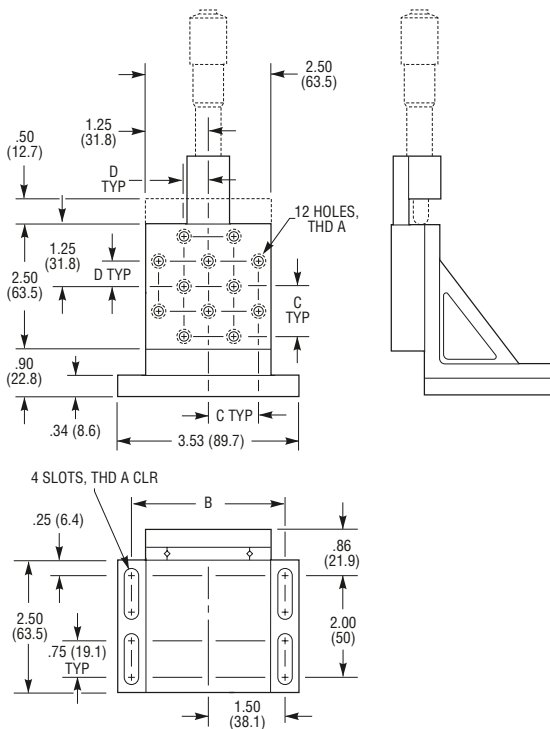

Model (Metric)	Thread	Dimension [in. (mm)]			
		A	B	C	D
462-X-M (M-462-X-M)	1/4-20 (M6)	3.0 (75)	1.000 (25.0)	0.500 (12.5)	
462-XY-M (M-462-XY-M)	1/4-20 (M6)	3.0 (75)	1.000 (25.0)	0.500 (12.5)	
462-XYZ-M (M-462-XYZ-M)	1/4-20 (M6)	3.0 (75)	1.000 (25.0)	0.500 (12.5)	
462-XZ-M (M-462-XZ-M)	1/4-20 (M6)	3.0 (75)	1.000 (25.0)	0.500 (12.5)	
462-Z-M (M-462-Z-M)	1/4-20 (M6)	3.0 (75)	1.000 (25.0)	0.500 (12.5)	