

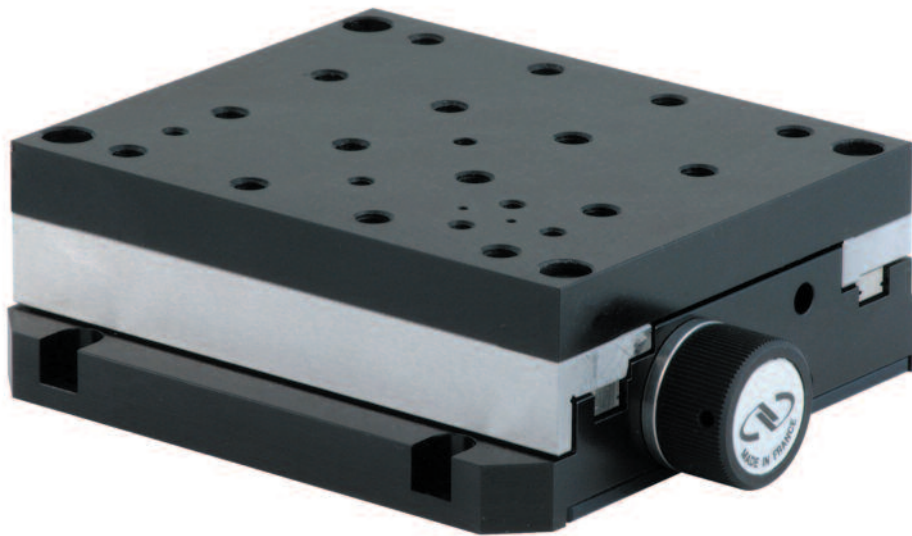

# VP-25XL

## High Precision Compact Linear Stage

---



 **Newport**<sup>®</sup>

**USER'S MANUAL**

# Warranty

Newport Corporation warrants this product to be free from defects in material and workmanship for a period of 1 year from the date of shipment. If found to be defective during the warranty period, the product will either be repaired or replaced at Newport's discretion.

To exercise this warranty, write or call your local Newport representative, or contact Newport headquarters in Irvine, California. You will be given prompt assistance and return instructions. Send the instrument, transportation prepaid, to the indicated service facility. Repairs will be made and the instrument returned, transportation prepaid. Repaired products are warranted for the balance of the original warranty period, or at least 90 days.

## Limitation of Warranty

This warranty does not apply to defects resulting from modification or misuse of any product or part.

---

### CAUTION

**Warranty does not apply to damages resulting from:**

- **Incorrect usage:**
  - **Load on the stage greater than maximum specified load.**
  - **Carriage speed higher than specified speed.**
  - **Improper grounding.**
    - **Connectors must be properly secured.**
    - **When the load on the stage represents an electrical risk, it must be connected to ground.**
  - **Excessive or improper cantilever loads.**
- **Modification of the stage or any part thereof.**



#### CAUTION

**Please return equipment in the original (or equivalent) packing.**

**You will be responsible for damage incurred from inadequate packaging if the original packaging is not used.**

---

This warranty is in lieu of all other warranties, expressed or implied, including any implied warranty of merchantability or fitness for a particular use. Newport Corporation shall not be liable for any indirect, special, or consequential damages.

© 2018 by Newport Corporation, Irvine, CA. All rights reserved.

Original instructions.

No part of this document may be reproduced or copied without the prior written approval of Newport Corporation. This document is provided for information only, and product specifications are subject to change without notice. Any change will be reflected in future publications.

# Table of Contents

Warranty .....	ii
EC Declaration of Conformity.....	v
Definitions and Symbols.....	vi
Warnings .....	vii
Caution .....	viii
<hr/>	
<b>1.0 — Introduction.....</b>	<b>1</b>
<hr/>	
<b>2.0 — Description .....</b>	<b>2</b>
2.1 Design Details .....	2
<hr/>	
<b>3.0 — Characteristics.....</b>	<b>3</b>
3.1 Definitions .....	3
3.2 Mechanical Specifications .....	4
3.3 Load Specification Definitions.....	4
3.4 Load Characteristics and Stiffness .....	5
3.5 Stage Weights .....	5
<hr/>	
<b>4.0 — Drive and Motor.....</b>	<b>6</b>
4.1 DC-Servo Drive Version.....	6
4.2 Sensor Position.....	6
4.3 Feedback Signal Position .....	7
4.4 Pinouts.....	7
Motor Cable (SUB-D25M Connector).....	7
Encoder Cable (SUB-D15M Connector with or without E3682A Adapter) .....	8
Encoder Cable (SUB-D26HDM Connector on E5820A Adapter) .....	8
<hr/>	
<b>5.0 — Connection to Newport Controllers.....</b>	<b>9</b>
5.1 Warnings on Controllers .....	9
5.2 Connection.....	10
5.3 Cables .....	10
5.4 Adapter for the XPS-Q Newport Controller .....	11
5.5 Adapter for the XPS-D Newport Controller.....	11
<hr/>	
<b>6.0 — Dimensions.....</b>	<b>12</b>
6.1 VP-25XL Stage.....	12
6.2 VP-25XL Stage without Top Plate Interface .....	12

---

<b>7.0</b>	<b>— Assemblies</b>	13
7.1	XY Mounting	13
7.2	XYZ Configuration	14

---

<b>8.0</b>	<b>— Maintenance</b>	15
8.1	Maintenance	15
8.2	Repair	15
8.3	Calibration	15

---

	Service Form	17
--	--------------	----

# EC Declaration of Conformity

## VP-25XL

**Newport®**

### EU Declaration of Conformity

following Annex II-1A  
of Directive 2006/42/EC on machinery

**The manufacturer:**

MICRO-CONTROLE Spectra-Physics,  
9 rue du Bois Sauvage  
F-91055 Evry FRANCE

**Hereby declares that the machinery:**

- Description: "VP-25XL"
- Function: High Precision Compact Linear Stage
- Models: (M-)VP-25XL

– the technical file of which was compiled by:

Mr Hervé LE COINTE , Quality Director,  
MICRO-CONTROLE Spectra-Physics, Zone Industrielle - B.P.29  
F-45340 Beauce La Rolande France

- complies with all the relevant provisions of the Directive 2006/42/EC on machinery.
- complies with all the relevant provisions of the Directive 2014/30/EU relating to electro-magnetic compatibility.
- complies with all the relevant provisions of the Directive 2011/65/EU relating to RoHS2.
- was designed and built in accordance with the following harmonised standards:
  - NF EN 61326-1:2013 « Electrical equipment for measurement, control and laboratory use – EMC requirements – Part 1: General requirements »
  - NF EN 55011:2010/A1:2011 Class A
- was designed and built in accordance with the following other standards:
  - NF EN 61000-4-2
  - NF EN 61000-4-3
  - NF EN 61000-4-4
  - NF EN 61000-4-5
  - NF EN 61000-4-6

#### ORIGINAL DECLARATION

Done in Beauce La Rolande on 16 May 2017  
Hervé LE COINTE  
Quality Director



DC1-EN rev:A

# Definitions and Symbols

The following terms and symbols are used in this documentation and also appear on the product where safety-related issues occur.

## General Warning or Caution



The exclamation symbol may appear in warning and caution tables in this document. This symbol designates an area where personal injury or damage to the equipment is possible.

The following are definitions of the Warnings, Cautions and Notes that may be used in this manual to call attention to important information regarding personal safety, safety and preservation of the equipment, or important tips.



---

### WARNING

**Warning indicates a potentially dangerous situation which can result in bodily harm or death.**

---



---

### CAUTION

**Caution indicates a potentially hazardous situation which can result in damage to product or equipment.**

---



---

### NOTE

**Note indicates additional information that must be considered by the user or operator.**

---

## European Union CE Mark



The presence of the CE Mark on Newport Corporation equipment means that it has been designed, tested and certified as complying with all applicable European Union (CE) regulations and recommendations.

## Warnings and Cautions



---

### ATTENTION

**This stage is a Class A device. In a residential environment, this device can cause electromagnetic interference. In this case, suitable measures must be taken by the user.**

---

# Warnings



---

## WARNING

The motion of objects of all types carries potential risks for operators. Ensure the protection of operators by prohibiting access to the dangerous area and by informing the personnel of the potential risks involved.

---

## WARNING

Do not use this stage when its motor is emitting smoke or is unusually hot to the touch or is emitting any unusual odor or noise or is in any other abnormal state.

Stop using the stage immediately, switch off the motor power and then disconnect the electronics power supply.

After checking that smoke is no longer being emitted contact your Newport service facility and request repairs. Never attempt to repair the stage yourself as this can be dangerous.

---

## WARNING

Make sure that this stage is not exposed to moisture and that liquid does not get into the stage.

Nevertheless, if any liquid has entered the stage, switch off the motor power and then disconnect the electronics from power supply.

Contact your Newport service facility and request repairs.

---



## WARNING

Do not insert or drop objects into this stage, this may cause an electric shock, or lock the drive.

Do not use this stage if any foreign objects have entered the stage. Switch off the motor power and then disconnect the electronics power supply.

Contact your Newport service facility for repairs.

---

## WARNING

Do not place this stage in unstable locations such as on a wobbly table or sloping surface, where it may fall or tip over and cause injury.

If this stage has been dropped or the case has been damaged, switch off the motor power and then disconnect the electronics power supply.

Contact your Newport service facility and request repairs.

---

## WARNING

Do not attempt to modify this stage; this may cause an electric shock or downgrade its performance.

---

## WARNING

Do not exceed the usable depth indicated on the mounting holes (see section “Dimensions”). Longer screws can damage the mechanics or cause a short-circuit.

# Caution

---

**CAUTION**

**Do not place this stage in a hostile environment such as X-Rays, hard UV,... or in any vacuum environment.**

---

**CAUTION**

**Do not place this stage in a location affected by dust, oil fumes, steam or high humidity. This may cause an electric shock.**

---

**CAUTION**

**Do not leave this stage in places subject to extremely high temperatures or low temperatures. This may cause an electric shock.**

- **Operating temperature: +10 to +35 °C**
  - **Storage temperature: -10 to +40 °C (in its original packaging)**
- 

**CAUTION**

**Do not move this stage if its motor power is on.**

**Make sure that the cable to the electronics is disconnected before moving the stage. Failure to do so may damage the cable and cause an electrical shock.**

---

**CAUTION**

**Be careful that the stage is not bumped when it is being carried. This may cause it to malfunction.**

---

**CAUTION**

**When handling this stage, always unplug the equipment from the power source for safety.**

---

**CAUTION**

**When the carriage is in its end-of-run position, it is strongly recommended not to go beyond this point as this may damage the stage mechanism.**

---

**CAUTION**

**Contact your Newport service facility to request cleaning and specification control every year.**

---

# High Precision Compact Linear Stage

## VP-25XL

### 1.0 Introduction

This manual provides operating instructions for the VP-25XL precision compact linear stage.



*VP-25XL translation stage.*

#### RECOMMENDATION

We recommend you read carefully the chapter “Connection to electronics” before using the VP-25XL stage.

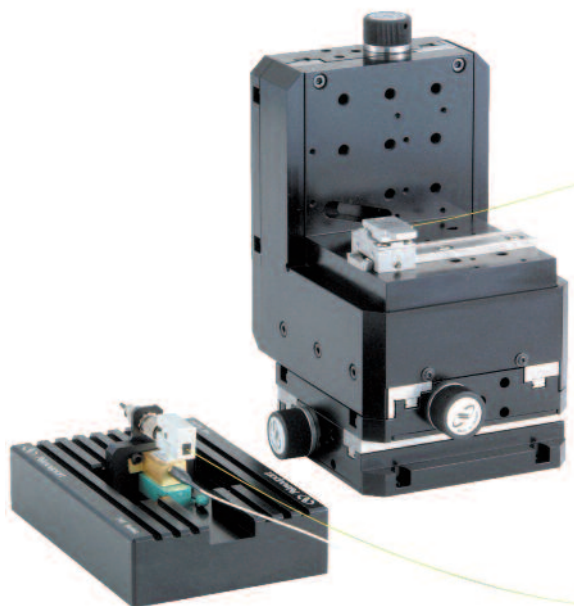

*3 VP-25XL stages in XYZ configuration.*

## 2.0 Description

The VP-25XL stages address multi-axis, high precision positioning requirements in fiber optics, biomedical, semiconductor, and high precision test and measurement applications. Features including its ultra-compact size and high reliability make them appropriate for device testing, micro-assembly, micro-machining, and manipulation of small, lightweight parts such as fiber optical devices, micro-optics, MEMS, cell probes, or semiconductor devices.

Based on a high precision drive technology including low-friction ball screw and recirculating ball bearings, the VP-25XL stages deliver highly reliable positioning performance at a maximum speed of 25 mm/s. Compared to alternative direct-drive technologies, the ball screw drive of the VP-25XL stages provides greater thrust for higher servo stiffness and load capacity, higher efficiency resulting in less heat induced position drift, as well as minimum tuning efforts. Furthermore, the self-locking at power-off considerably simplifies operational safety.

The modular VP-25XL stages enable the construction of compact multi-axes positioning systems. For example, by combining three VP-25XL stages with the VP-BK bracket, a versatile and compact 3 degrees of motion system is produced, keeping the height of the horizontal mounting plate as low as 105 mm ( $\pm 12.7$  mm). For applications requiring up to 6 degrees of motion, our SR50 and PR50 rotation stages and GON series goniometers can be easily added to the system. This complete modular approach provides the greatest advantage regarding flexibility, customization, performance, and ease-of-use.

The VP-25XL provides a 1  $V_{PP}$  analog encoder interface. When using with our XPS motion controller, these stages deliver a reliable 10 nm motion sensitivity, and better than 140 nm bidirectional repeatability.

The stage is equipped with two cables of 3 m length with one SUB-D25 and one SUB-D15 connector for connection to our XPS controller.

### 2.1 Design Details

Base Material	Aluminum
Bearings	Recirculating ball bearings
Drive Mechanism	Backlash-free ball screw
Drive Screw Pitch	1 mm
Feedback	Linear steel scale, 20 $\mu$ m signal period, 1 $V_{PP}$ analog sine-cosine output
Limit	Switches Optical
Origin	Optical, at center of travel
Motor	DC servo motor with Tachometer UE25CC
Cable Length	3 m

## 3.0 Characteristics

### 3.1 Definitions

Specifications of our products are established in reference to ISO 230 standard part II “Determination of accuracy and repeatability of positioning numerically controlled axes”.

This standard gives the definition of position uncertainty which depends on the 3 following parameters:

#### **Absolute Accuracy**

Difference between ideal position and real position.

#### **Accuracy**

Difference between ideal position and real position after the compensation of linear errors.

Linear errors include: cosine errors, inaccuracy of screw or linear scale pitch, angular deviation at the measuring point (Abbe error) and thermal expansion effects. All Newport motion electronics can compensate for linear errors.

The relation between absolute accuracy and on-axis accuracy is as follows:

$$\text{Absolute Accuracy} = \text{Accuracy} + \text{Correction Factor} \times \text{Travel}$$

#### **Repeatability**

Ability of a system to achieve a commanded position over many attempts.

#### **Reversal Value (Hysteresis)**

Difference between actual position values obtained for a given target position when approached from opposite directions.

#### **Minimum Incremental Motion (MIM or Sensitivity)**

The smallest increment of motion a device is capable of delivering consistently and reliably.

#### **Resolution**

The smallest increment that a motion device can theoretically move and/or detect. Resolution is not achievable, whereas MIM, is the real output of a motion system.

#### **Yaw, Pitch**

Rotation of carriage around the Z axis (Yaw) or Y axis (Pitch), when it moves.

The testing of accuracy, repeatability, and reversal error are made systematically with test equipment in controlled environment (20<sup>±1</sup> °C).

A linear cycle with 21 data points on the travel and 4 cycles in each direction gives a total of 168 points.

### **Guaranteed and Typical Specifications**

Guaranteed maximum performance values are verified per Newport's A167 metrology test procedure. For more information, please consult the metrology tutorial section in the Newport catalog or at [www.newport.com](http://www.newport.com)

### 3.2 Mechanical Specifications



Travel Range (mm)	25
Minimum Incremental Motion (μm)	0.01
Bi-directional Repeatability, Typical (Guaranteed) <sup>(1)</sup> (μm)	±0.05 (±0.07)
Accuracy, Typical (Guaranteed) <sup>(1)</sup> (μm)	±0.5 (±1.0)
Maximum Speed (mm/s)	25
Pitch, Typical (Guaranteed) <sup>(1)(2)</sup> (μrad)	±20 (±50)
Yaw, Typical (Guaranteed) <sup>(1)(2)</sup> (μrad)	±20 (±50)
MTBF (h)	20,000

<sup>1)</sup> For the definition of Typical and Guaranteed specifications see "Motion Basics Terminology & Standards" Tutorial at [www.newport.com](http://www.newport.com)

<sup>2)</sup> To obtain arcsec units, divide μrad value by 4.8.



#### CAUTION

To reach specifications stated, stages must be fixed on a plane surface with a flatness of 5 μm.

The MTBF value indicated above is given to use the stage with the following parameters:

Centered load	50 N
Displacements	2 mm
Speed	10 mm/s
Operating rate on the cycle	50%
Cycle	21 hours/day, 330 days/year

### 3.3 Load Specification Definitions

#### Normal Load Capacity (Cz)

Maximum load a stage can move while maintaining specifications.

This value is given with speed and acceleration specified for each stage, and with a load perpendicular to bearings.

Max. Speed (mm/s)	25
Max. Acceleration (mm/s <sup>2</sup> )	100

#### Axial Load Capacity (±Cx)

Maximum load along the direction of the drive train.

#### Off-Centered Load (Q)

Maximum cantilever-load a stage can move:  $Q \leq Cz \div (1 + D/a)$

D: Cantilever distance.

a: Construction parameter.

### 3.4 Load Characteristics and Stiffness

#### Normal Load Characteristics

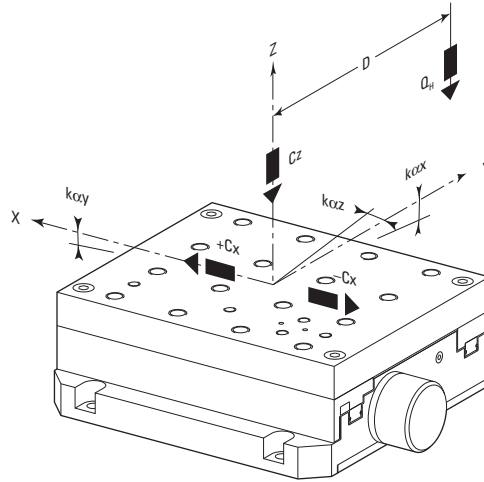

Cz, Normal centered load capacity	60 N
-Cx, +Cx, Axial load capacity	40 N
Kαx, Compliance in roll	20 μrad/Nm
Kαy, Compliance in pitch	20 μrad/Nm
Kαz, Compliance in yaw	30 μrad/Nm
QH, Off-center load (N)	$Q_H \leq C_z \div (1 + D/30)$
Where D = Cantilever distance (mm)	

#### Axial Load Characteristics

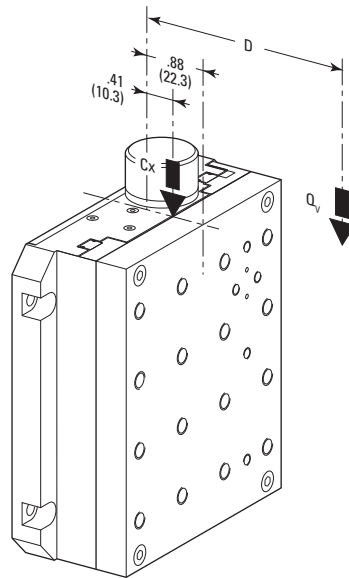

Cv, Off-center load (N)	$C_v \leq C_z \div (1 + D/30)$
Where D = Cantilever distance in mm between the center of mass of the load and the bearings center (mm)	
Distance between top surface and the bearings center	22.3 mm
Distance between under the top plate and the bearings center	10.3 mm

### 3.5 Stage Weights

The stage weight below includes the top plate and the cable.

	Weight [lb (kg)]
VP-25XL	3.3 (1.5)

**4.0 Drive and Motor**

**4.1 DC-Servo Drive Version**

The VP-25XL stage is equipped with DC-motor and a metal optical scale.

**DC-Motor Performance Specifications and Characteristics**

	Resolution ( $\mu\text{m}$ )	Speed (mm/s)	Nominal Voltage (V)	Max RMS Current (A)	Max. Peak Current (A)	Resistance ( $\Omega$ )	Inductance (mH)	Tachometer Const. (V/krpm)
<b>VP-25XL</b>	0.6 (1)	25	48	0.5	1	8	0.83	0.52

<sup>1)</sup> XPS internal resolution used for position calculation, approx. 5 nm noise on position.

**Command Signals for the DC-Motor**

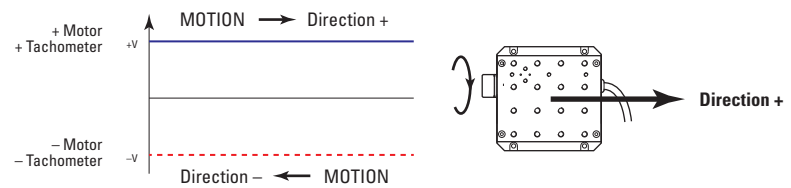

In the above drawings, + Motor signal is referred to - Motor signal, + Tacho Generator signal is referred to - Tacho Generator signal.

- ① When the stage moves in + Direction, the + Motor voltage is higher than - Motor voltage, and + Tacho Generator voltage is higher than - Tacho Generator voltage.
- ② When the stage moves in - Direction, the + Motor voltage is lower than - Motor voltage, and + Tacho Generator voltage is lower than - Tacho Generator voltage.

**4.2 Sensor Position**

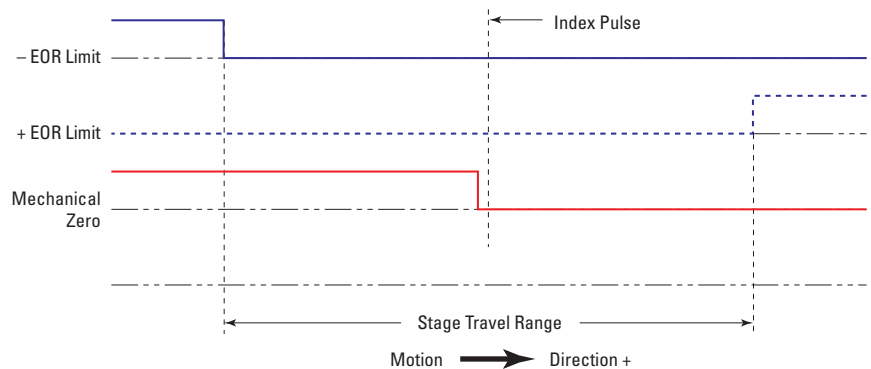

End-of-Run and Mechanical Zero are 5 V open collector type.



**CAUTION**

**“End-of-Run” and “Mechanical Zero” are active signals and should not be connected to any other source.**

### 4.3 Feedback Signal Position

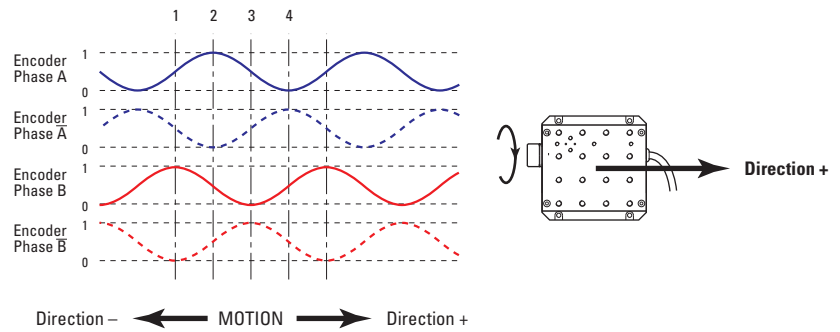

The incremental shaft encoder consists of an optical scale and an encoder head. When the sensor shaft turns, the encoder head generates sine-cosine signals in quadrature, sent to pins #1, #3, #9 and #11 of the SUB-D15 connector.

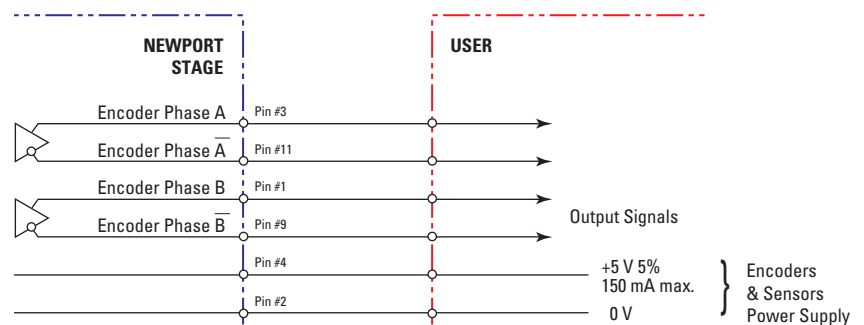

“Encoder” and “Index Pulse” are “differential pair” (type RS-422) type output signals. Using these signals permits a high immunity to noise. Emission circuits generally used by Newport are 26LS31 or MC3487. Reception circuits to use are 26LS32 or MC3486.

### 4.4 Pinouts

#### 4.4.1 Motor Cable (SUB-D25M Connector)

The SUB-D25M connection for the VP-25XL stages is given in the following table:

1	+ Tachometer	14	Ground
2	N.C.	15	N.C.
3	- Tachometer	16	0 V
4	N.C.	17	+ End-of-Run
5	+ Motor	18	- End-of-Run
6	+ Motor	19	N.C.
7	- Motor	20	N.C.
8	- Motor	21	N.C.
9	N.C.	22	N.C.
10	N.C.	23	N.C.
11	N.C.	24	N.C.
12	N.C.	25	N.C.
13	Mechanical Zero		

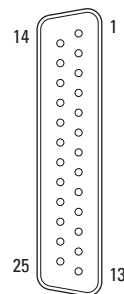

**4.4.2 Encoder Cable (SUB-D15M Connector with or without E3682A Adapter)**

The E3682A adapter allows to connect the encoder cable with our XPS-Q controller.

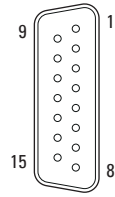

1	Encoder Phase B
2	0 V
3	Encoder Phase A
4	+5 V
5	N.C.
6	N.C.
7	Index Pulse /I
8	N.C.
9	Encoder Phase /B
10	N.C.
11	Encoder Phase /A
12	N.C.
13	N.C.
14	Index Pulse I
15	N.C.

**4.4.3 Encoder Cable (SUB-D26HDM Connector on E5820A Adapter)**

The E5820A adapter allows to connect the encoder cable with our XPS-D controller.

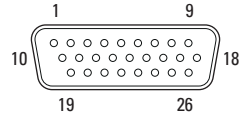

1	+5 V	14	N.C.
2	N.C.	15	Encoder Phase /A
3	N.C.	16	N.C.
4	Encoder Phase B	17	Index Pulse /I
5	N.C.	18	N.C.
6	Encoder Phase A	19	N.C.
7	0 V	20	N.C.
8	Index Pulse I	21	N.C.
9	N.C.	22	N.C.
10	N.C.	23	N.C.
11	N.C.	24	N.C.
12	N.C.	25	N.C.
13	Encoder Phase /B	26	N.C.

## 5.0 Connection to Newport Controllers

### 5.1 Warnings on Controllers

Controllers are intended for use by qualified personnel who recognize shock hazards and are familiar with safety precautions required to avoid possible injury. Read the controller user's manual carefully before operating the instrument and pay attention to all written warnings and cautions.

---

#### WARNING

Disconnect the power plug under the following circumstances:

- If the power cord or any attached cables are frayed or damaged in any way.
- If the power plug is damaged in any way.
- If the unit is exposed to rain, excessive moisture, or liquids are spilled on the unit.
- If the unit has been dropped or the case is damaged.
- If you suspect service or repair is required.
- Whenever you clean the electronics unit.

---

#### CAUTION

To protect the unit from damage, be sure to:

- Keep all air vents free of dirt and dust.
- Keep all liquids away from the unit.
- Do not expose the unit to excessive moisture (85% humidity).
- Read this manual before using the unit for the first time.



---

#### WARNING

All attachment plug receptacles in the vicinity of this unit are to be of the grounding type and properly polarized.

Contact your electrician to check your receptacles.

---

#### WARNING

This product is equipped with a 3-wire grounding type plug.

Any interruption of the grounding connection can create an electric shock hazard.

If you are unable to insert the plug into your wall plug receptacle, contact your electrician to perform the necessary alterations to ensure that the green (green-yellow) wire is attached to earth ground.

---

#### WARNING

This product operates with voltages that can be lethal.

Pushing objects of any kind into cabinet slots or holes, or spilling any liquid on the product, may touch hazardous voltage points or short out parts.

---

## 5.2 Connection

There is a label on every stage indicating its part and serial numbers.

---

### WARNING

Always turn the controller's power OFF before connecting to a stage.

---

### WARNING

The VP-25XL stage SUB-D25 connector must be connected to an XPS-DRV03 driver board.



THE SUB-D25 CABLE  
MUST BE PLUGGED TO  
ONE OF THESE CONNECTORS

THE SUB-D15 CABLE MUST BE PLUGGED  
TO THE CORRESPONDING NUMBER  
ENCODER CONNECTOR

The VP-25XL stage SUB-D15 connector must be connected to the XPS rear panel "Encoder" connector corresponding to number of the axis on which the above mentioned XPS-DRV03 is connected to.

---

## 5.3 Cables

The VP-25XL stage is delivered equipped with two 3-meter cables, one with a SUB-D15 connector and the other one with a SUB-D25 connector.

The motor cable can be directly connected to our XPS controllers.

The encoder cable can be either directly connected to our XPS-RL controller or connected with an adapter for both XPS-Q and XPS-D controllers.

---

### WARNING

These cables are shielded correctly. For a correct operation, make sure to lock connectors (ground continuity provided by the cable).

---



### WARNING

Keep the motor cables at a safe distance from other electrical cables in your environment to avoid potential cross talk.

---

#### 5.4 Adapter for the XPS-Q Newport Controller

The E3682A adapter supplied with each VP-25XL stage, allows the connection of the encoder cable with our XPS-Q controller.



---

#### NOTE

**This adapter must only be mounted on the encoder cable when connecting with the XPS-Q Newport Controller. It must not be mounted for the XPS-RL Newport Controller.**

---

#### 5.5 Adapter for the XPS-D Newport Controller

The E5820A adapter supplied with each VP-25XL stage, allows the connection of the encoder cable with our XPS-D controller.



---

#### NOTE

**This adapter must only be mounted on the encoder cable when connecting with the XPS-D Newport Controller.**

---

6.0 Dimensions

6.1 VP-25XL Stage

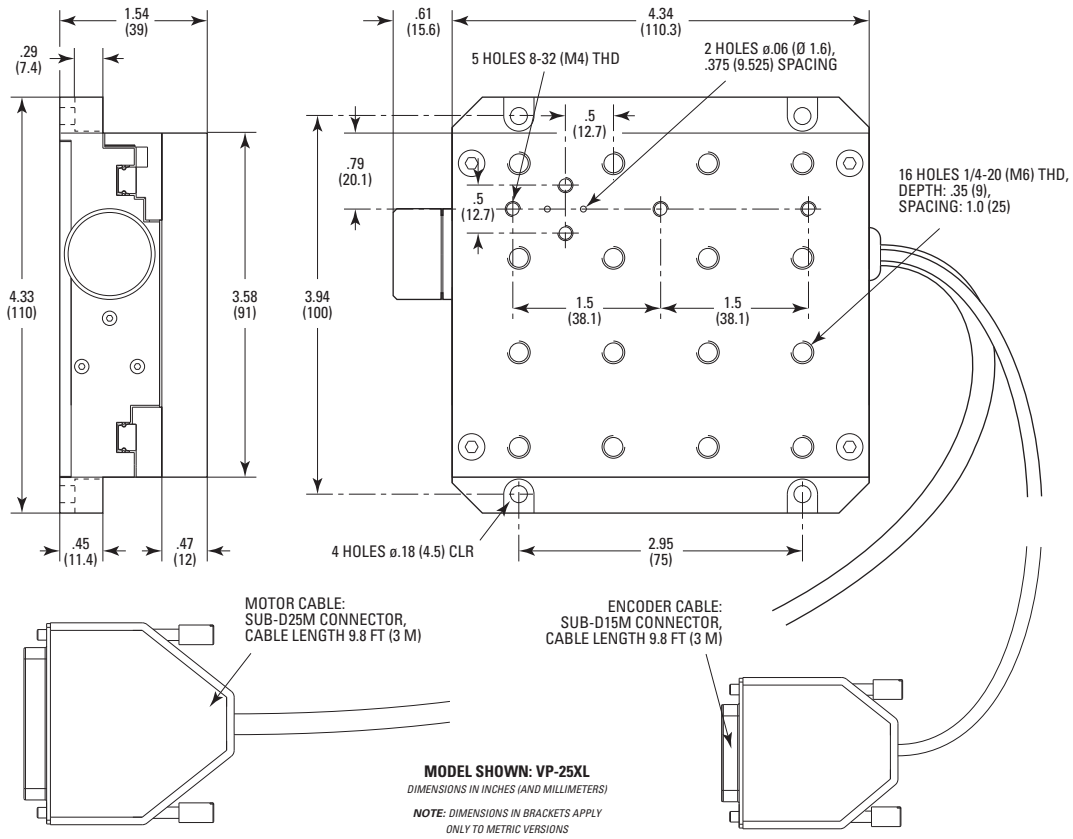

6.2 VP-25XL Stage without Top Plate Interface

Sometimes, it is necessary to remove the top plate interface of a VP-25XL stage (to make an XY assembly, for example).

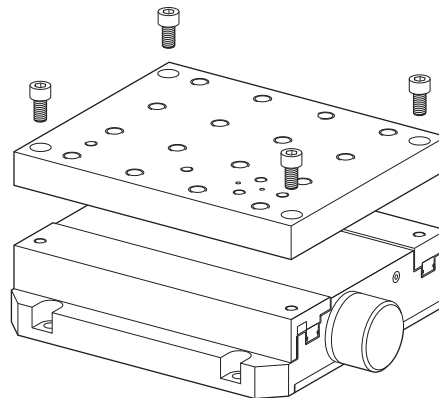

To do so, just unscrew the 4 CHc M4 x 12 / □ 100 x 75 screws of the top plate with the wrench supplied with the stage.

VP-25XL stage will then have the following interface:

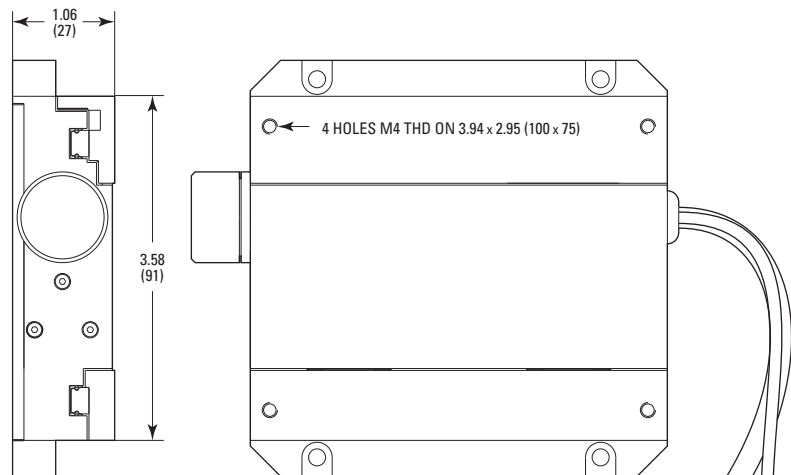

**CAUTION**

Once the top plate interface removed, one of carriages is floating on its axis.

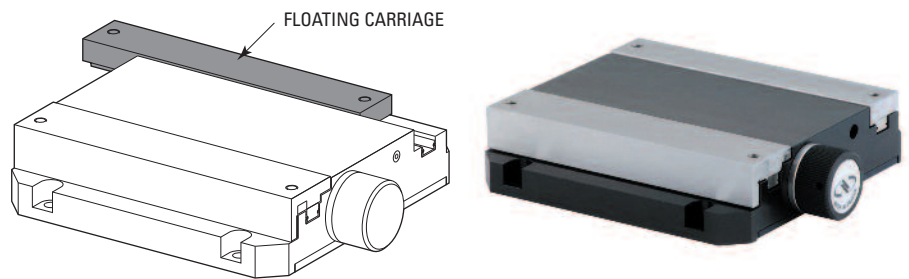

**7.0 Assemblies**

**7.1 XY Mounting**

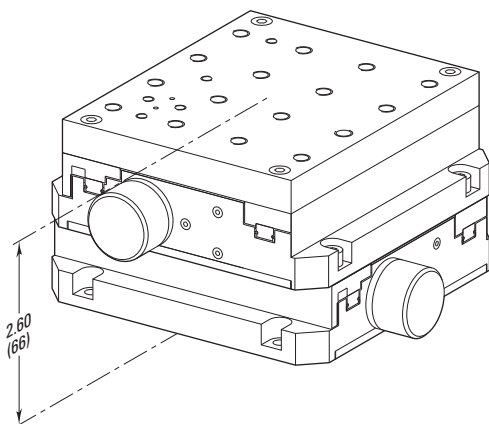

**CAUTION**

- To make an XY stage assembly, it is necessary to tighten screws firstly on the driving carriage of the lower stage, then the ones on the floating carriage.
- The lower stage must be fixed on a plane surface with a flatness of 5  $\mu$ m.

### 7.2 XYZ Configuration

VP-25XL stages can easily be assembled into XYZ configuration with optional VP-BK bracket.

**MODEL SHOWN: (M-)VP-25XA-XYZL**  
 DIMENSIONS IN INCHES (AND MILLIMETERS)  
 NOTE: DIMENSIONS IN BRACKETS APPLY ONLY TO METRIC VERSIONS

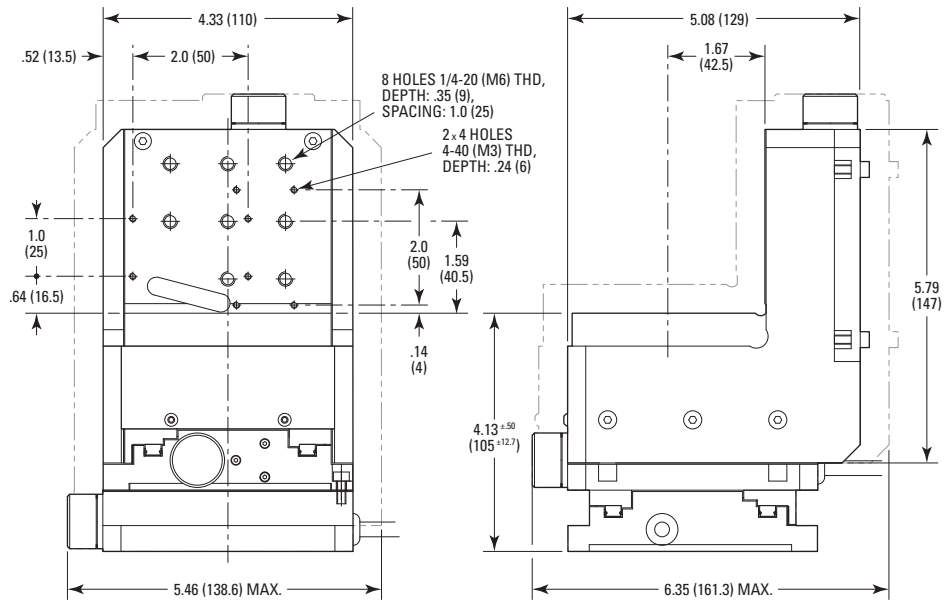
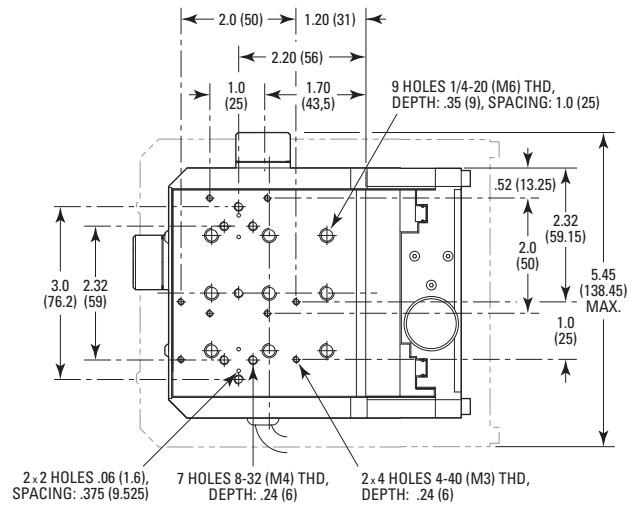

#### CAUTION

- To fix stages together or with the bracket for an XYZ assembly, it is necessary to tighten screws firstly on the driving carriage, then the ones on the floating carriage.
- The lower stage must be fixed on a plane surface with a flatness of 5 µm.

## 8.0 Maintenance

---

### RECOMMENDATION

**Please contact Technical Sales Support team for recommendations on application specific maintenance.**

---

#### 8.1 Maintenance

The VP-25XL table requires no particular maintenance. Nevertheless, this is a precision mechanical device that must be kept and operated with caution.

---

### PRECAUTIONS

**The VP-25XL table must be used or stocked in a clean environment, without dust, humidity, solvents or other substances.**

---

### RECOMMENDATION

**It is recommended to return the stage to Newport for re-lubrication after 2000 hours of use.**

**If the VP-25XL table is mounted on a workstation and cannot be easily removed, please contact Newport's After Sales Service for further instructions.**

---

#### 8.2 Repair

### CAUTION



**Never attempt to disassemble a component of the stage that has not been covered in this manual.**

**To disassemble a non specified component can cause a malfunction of the stage.**

---

If you observe a malfunction in your table, please contact us immediately to arrange for a repair.

---



### CAUTION

**Any attempt to disassemble or repair a table without prior authorization will void your warranty.**

---

#### 8.3 Calibration



### CAUTION

**It is recommended to return your VP-25XL table to Newport once a year for recalibration to its original specifications.**

---







Visit Newport Online at:  
[www.newport.com](http://www.newport.com)

**North America & Asia**

Newport Corporation  
1791 Deere Ave.  
Irvine, CA 92606, USA

**Sales**

Tel.: (800) 222-6440  
e-mail: [sales@newport.com](mailto:sales@newport.com)

**Technical Support**

Tel.: (800) 222-6440  
e-mail: [tech@newport.com](mailto:tech@newport.com)

**Service, RMAs & Returns**

Tel.: (800) 222-6440  
e-mail: [service@newport.com](mailto:service@newport.com)

**Europe**

MICRO-CONTROLE Spectra-Physics S.A.S  
9, rue du Bois Sauvage  
91055 Évry CEDEX  
France

**Sales & Technical Support**

Tel.: +33 (0)1.60.91.68.68  
e-mail: [france@newport.com](mailto:france@newport.com)

**Service & Returns**

Tel.: +33 (0)2.38.40.51.55

