

# Lect. 22: Lasers

---

Optical Amplifier

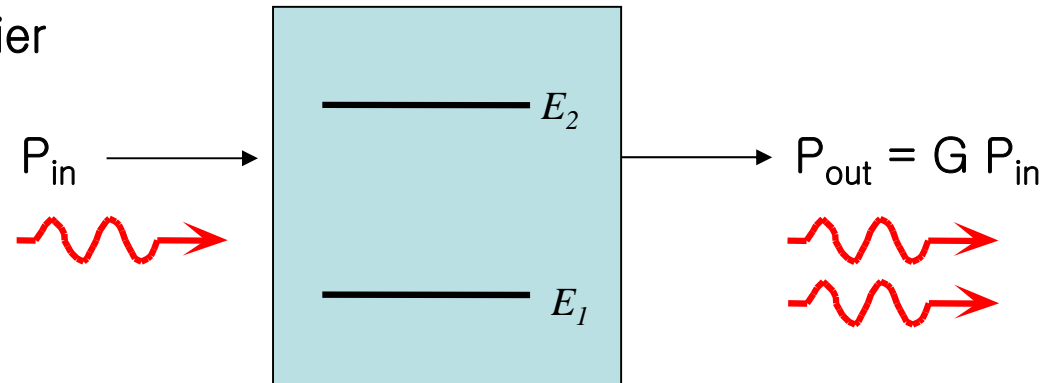

Light source based on stimulated emission?

- Use photons produced by spontaneous emission as initial seeds
- Recycle photons for further stimulated emission
- Use mirror for recycling photons

➔ LASER: Light Amplification by Stimulated Emission Radiation

# Lect. 22: Lasers

---

LASER: Optical Amplifier + Mirror

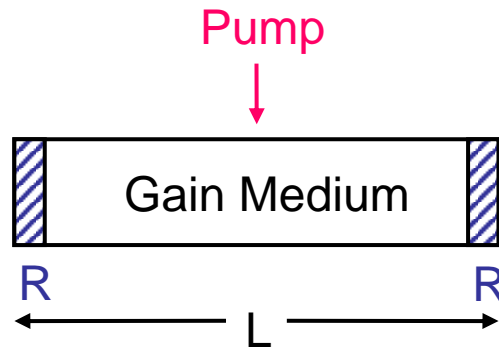

Optical property of gain medium:  $n$ ,  $g$

Imaginary part for  $k$ ?

$$k = nk_0 + j\frac{g}{2}$$

$g$  is due to absorption and stimulated emission

$g$  depends on material property,  $\lambda$ , amount of pumping

factor of 2 because  $g$  is often defined for power

# Lect. 22: Lasers

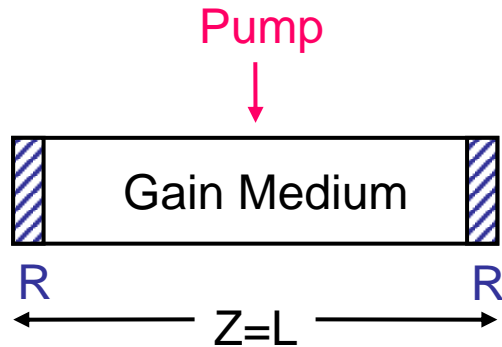

$$k = nk_0 + j\frac{g}{2}$$

Assume initially there are photons moving in z-direction inside gain medium

What is the condition that the same number of photons are maintained within?

➔ No net loss after one round trip

$$E_0 \cdot e^{-jkL} \cdot r \cdot e^{-jkL} \cdot r = E_0$$

$$r^2 \cdot e^{-j2kL} = 1 \quad e^{-j2kL} = \frac{1}{r^2} = \frac{1}{R}$$

$$e^{-j2nk_0L} e^{gL} = \frac{1}{R} \quad \therefore e^{gL} = \frac{1}{R} \quad \text{and} \quad e^{-j2nk_0L} = 1$$

# Lect. 22: Lasers

$$e^{gL} = \frac{1}{R} \quad \text{and} \quad e^{-j2nk_0L} = 1$$

$$\text{From } e^{gL} = \frac{1}{R}, \quad g_{\text{th}} = \frac{1}{L} \ln \frac{1}{R} \quad (\text{Threshold gain})$$

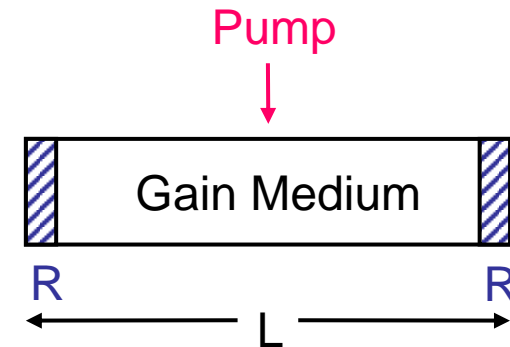

→ Laser must have sufficient gain to compensate mirror loss

$$\text{From } e^{-j2nk_0L} = 1, \quad 2nk_0L = 2m\pi \Rightarrow \frac{\lambda}{n} = \frac{2L}{m} \quad \text{or} \quad L = m \frac{\lambda}{2n}$$

Cavity length should be multiples of half wavelength (lasing mode)

→ Photons are in phase after one round trip

# Lect. 22: Lasers

Two conditions for lasing: (1)  $g_{\text{th}} = \frac{1}{L} \ln \frac{1}{R}$  and (2)  $\frac{\lambda}{n} = \frac{2L}{m}$

Gain is function of wavelength due to gain material characteristics

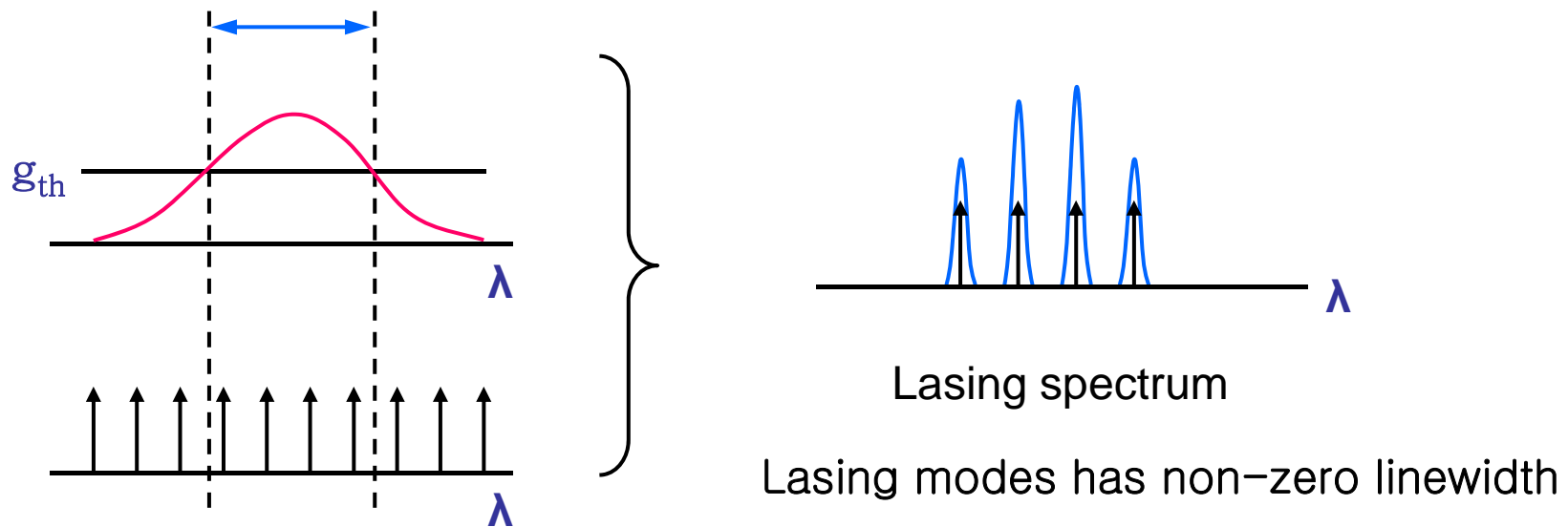

# Lect. 22: Lasers

Any optical gain material with mirrors can be a laser

First laser demonstrated by Maiman  
in 1960 at Hughes Aircraft Company



Ted Maiman  
(1927–2007)

Optical Gain Material: Cr in  $\text{Al}_2\text{O}_3$

Pump: Xenon flash lamp

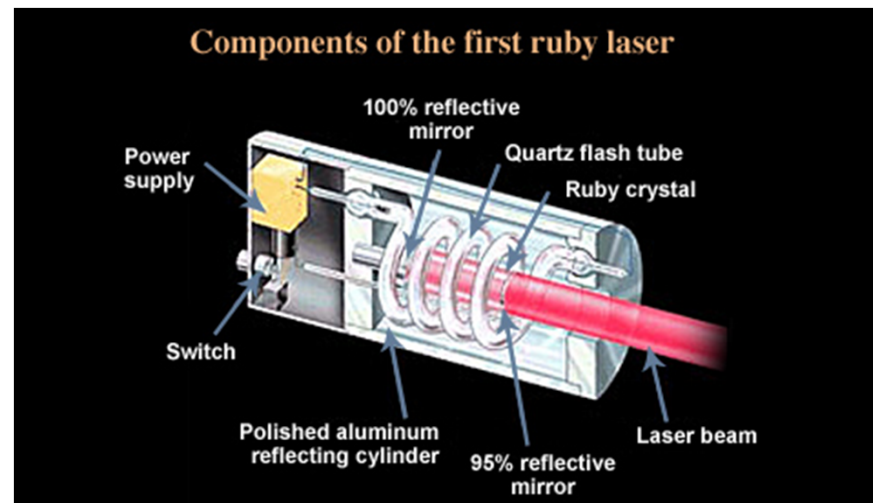
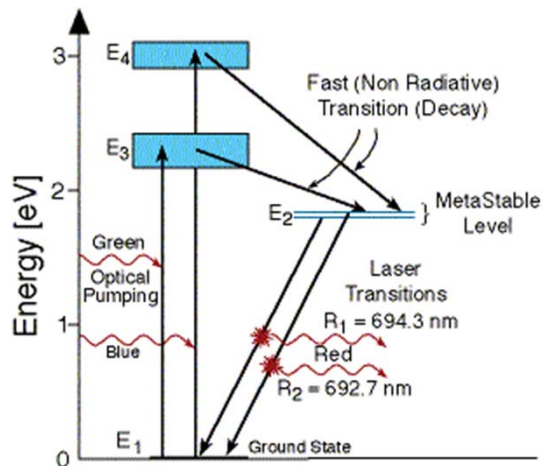

# Lect. 22: Lasers

---

1964 Nobel Prize in Physics for invention of laser



Charles Townes  
(1915–2015)  
(1/2)



Nikolay Basov  
(1922–2001)  
(1/4)



Aleksandr Prokhorov  
(1916–2002)  
(1/4)

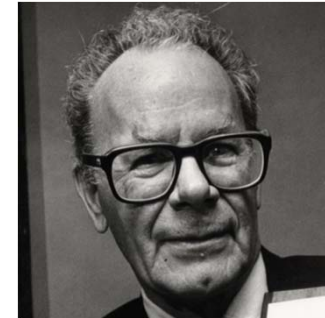

Gordon Gould  
(1920–2005)

30 year battle  
for laser patent

# Lect. 22: Lasers

## Gas Laser (HeNe)

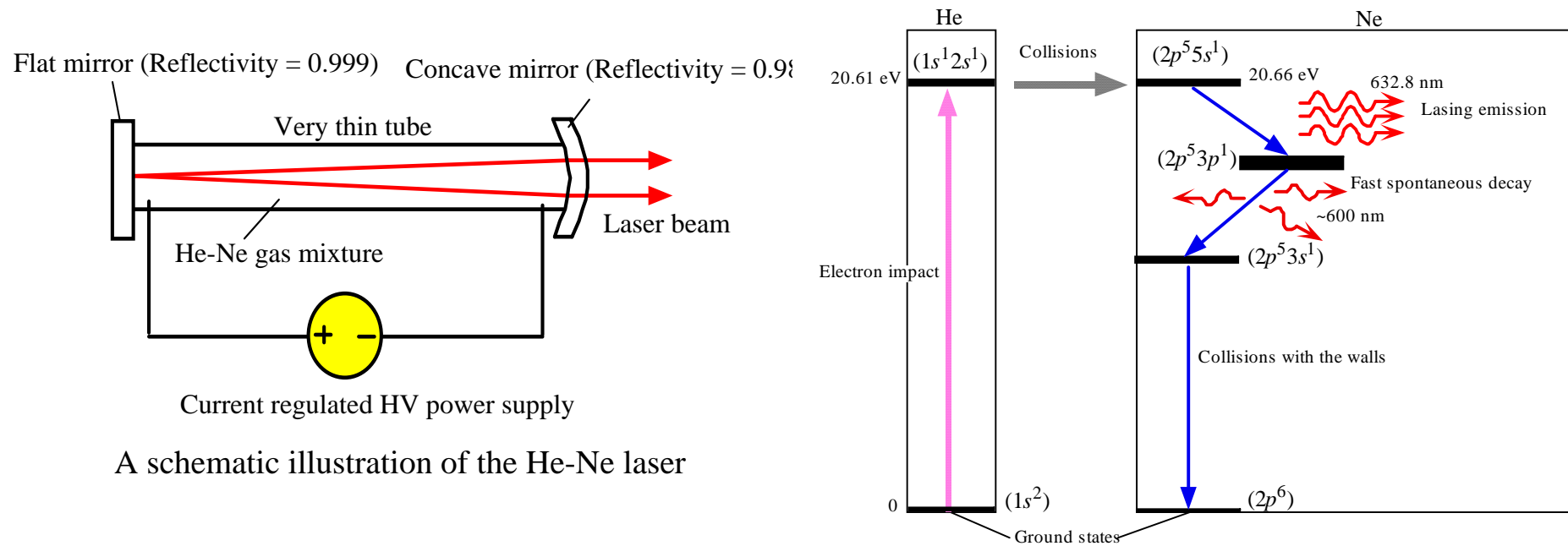

A schematic illustration of the He-Ne laser



# Lect. 22: Lasers

## Fiber Laser

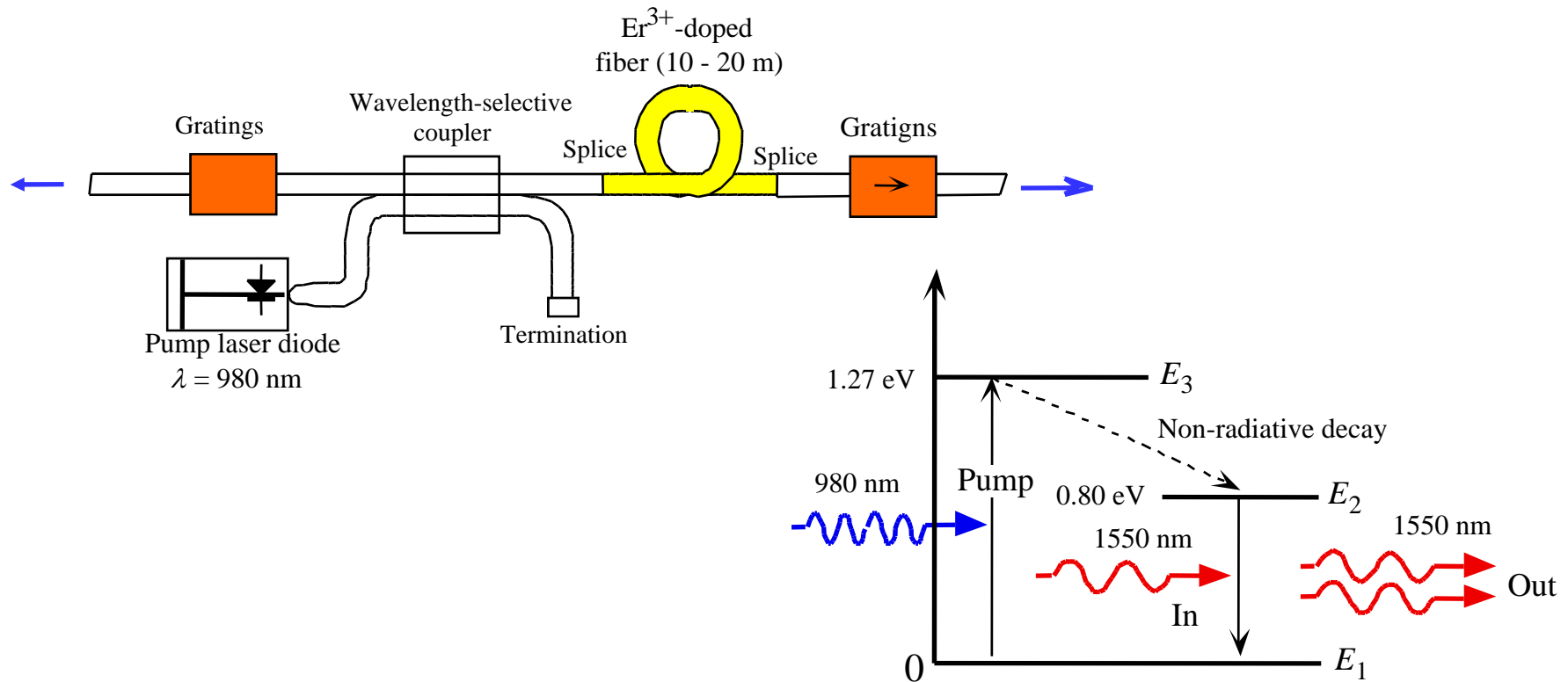

Another popular laser material: semiconductors

# Lect. 22: Lasers

## Homework

A fiber ring laser lasing around  $1.55\mu\text{m}$  is realized with a piece of Er-doped fiber (EDF) and a 3-dB beam splitter as shown below. The 3-dB beam splitter divides the input power into two equal output powers. Assume all the pump power transmitted by the beam splitter is absorbed by EDF and the resulting excited carriers are uniformly distributed within EDF. Also assume the reflected pump power is filtered out by an optical filter so that only the laser output is present at the output. Values of parameters that are needed to solve this problem are given below.

$\Gamma$  (EDF confinement factor): 0.1  
 $l$  (EDF length): 1m  
 $g$  (gain in EDF) =  $a(N - N_0)$   
where  $a = 10^{-24} \text{m}^2$ ,  $N_0 = 10^{25} \text{m}^{-3}$   
 $\lambda_{\text{pump}} = 0.98\mu\text{m}$   
 $n_{\text{eff}}$  (at  $1.55\mu\text{m}$ ) = 1.55

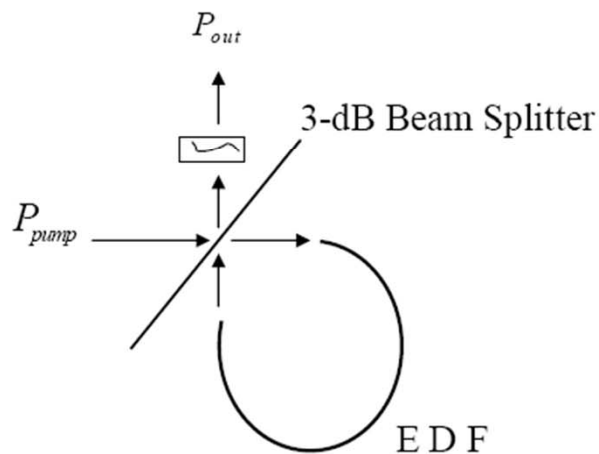

- What is the threshold gain of the laser in  $1/\text{m}$ ?
- What is the excited carrier density at the threshold in  $1/\text{m}^3$ ?
- The laser produces multi-mode lasing spectrum. What is the mode separation in wavelength at around  $1.55\mu\text{m}$ ? (Hint: Remember free spectral range in Lect. 9)